

REVISIONS

P	LTR	DESCRIPTION	DATE	DWN	APVD
A		RELEASE TO PRODUCTION	19OCT2023	Ka	SS
A1		DIMENSION TOLERANCE CORRECTION	29FEB2024	KA	SS
A2		PART OBSOLETE	18NOV2025	LS	RKS

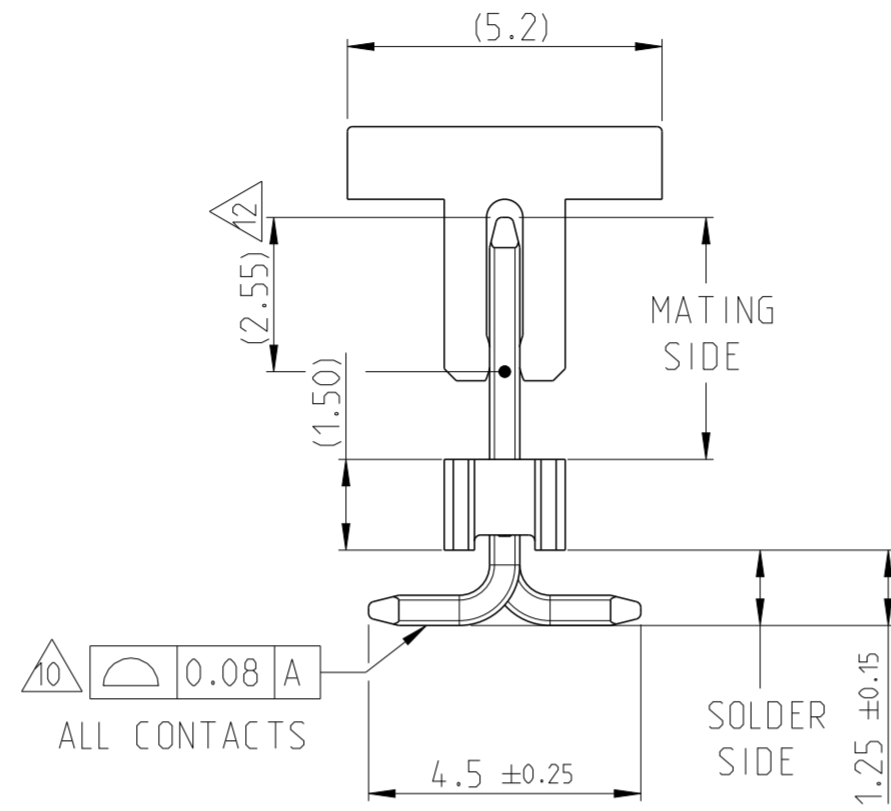
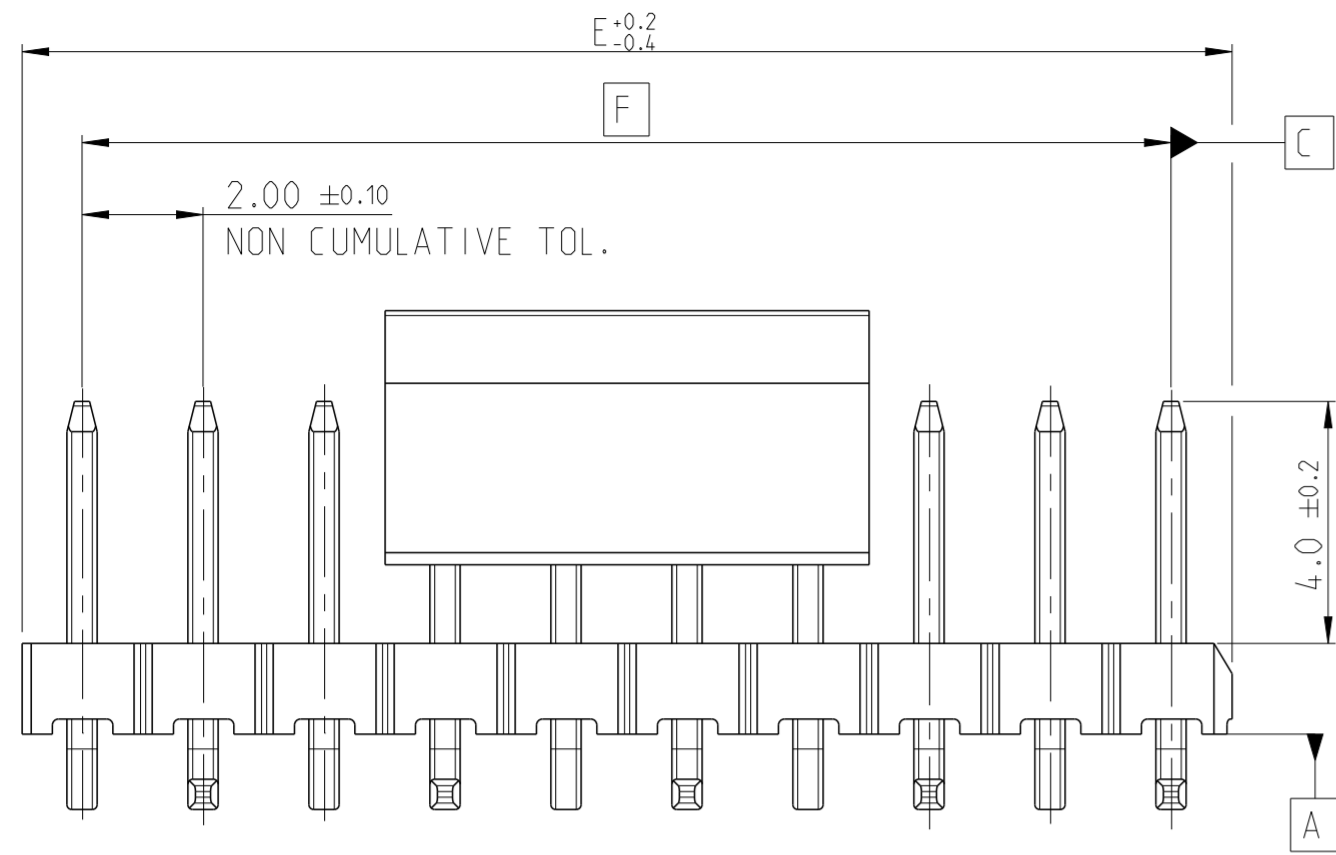

NOTES:

1. MATERIAL: HOUSING & P&P CAP: HIGH TEMPERATURE THERMOPLASTIC, UL94-V0; COLOR- BLACK POST: PHOSPHOR BRONZE

FINISH :

- 2 3-5µm TIN OVER MIN. 1.27µm NICKEL UNDER PLATING
- 3 MATING SIDE: MIN. 0.1µm SELECTIVE GOLD OVER MIN. 1.27µm NICKEL UNDER PLATING  
SOLDER SIDE: 4-6µm TIN OVER MIN. 1.27µm NICKEL UNDER PLATING
- 4 MATING SIDE: MIN. 0.38µm SELECTIVE GOLD OVER MIN. 1.27µm NICKEL UNDER PLATING  
SOLDER SIDE: 4-6µm TIN OVER MIN. 1.27µm NICKEL UNDER PLATING
- 5 MATING SIDE: MIN. 0.76µm SELECTIVE GOLD OVER MIN. 1.27µm NICKEL UNDER PLATING  
SOLDER SIDE: 4-6µm TIN OVER MIN. 1.27µm NICKEL UNDER PLATING

6. FOR SMART PART NUMBER, NO. OF POSITIONS PER CONNECTOR HAS TO BE ADDED NEXT TO NO. OF ROWS (2MM-HB-S\_\_-VS-00-\_\_-\_\_). REFER SHEET 2 NOMENCLATURE FOR EXAMPLE: 2MM-HB-S04-VS-00-T-TBP = 4 POSITION. 2MM-HB-S25-VS-00-T-TBP = 25 POSITION.

7. NOTE DELETED.

8 FOR TUBE PACKAGING W/CAP: NO PICK AND PLACE CAP FOR -2 AND -3 POS. HEADER POSITION STARTS FROM -4 POS.

9. NOTE DELETED.

10 COPLANARITY VARIES WITH CONNECTOR POSITION  
2-10 POS: 0.08mm  
11-20 POS: 0.10mm  
21-25 POS: 0.15mm

11 EDGE SHOWN AS MOULDED FOR REFERENCE.

12 PLATING THICKNESS MEASUREMENT POINT REFERENCE FOR SELECTIVE GOLD PLATING AREA

13 OBSOLETE

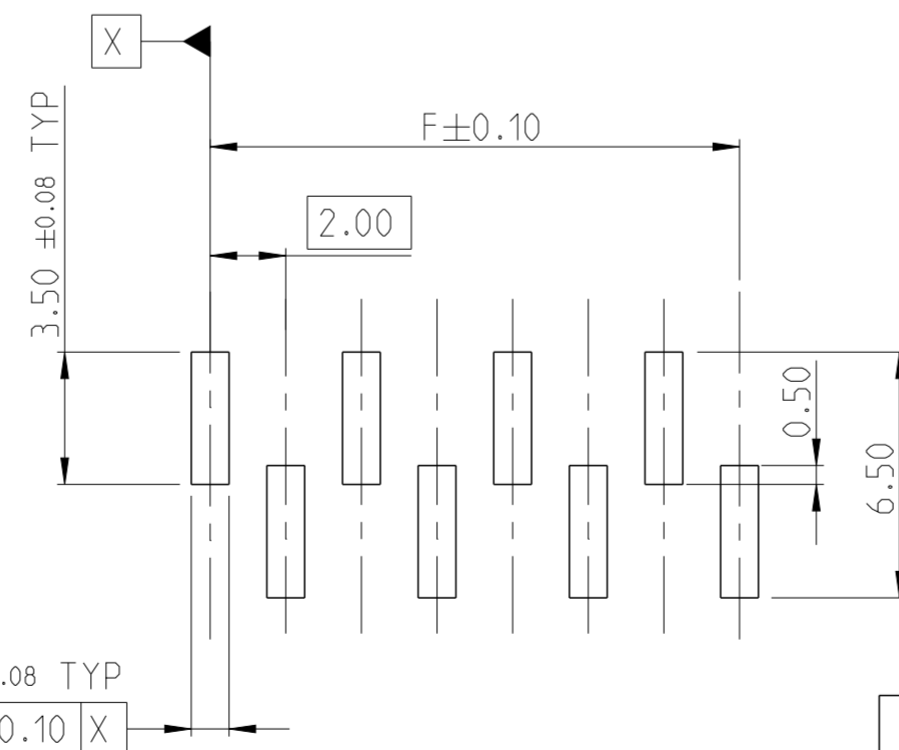
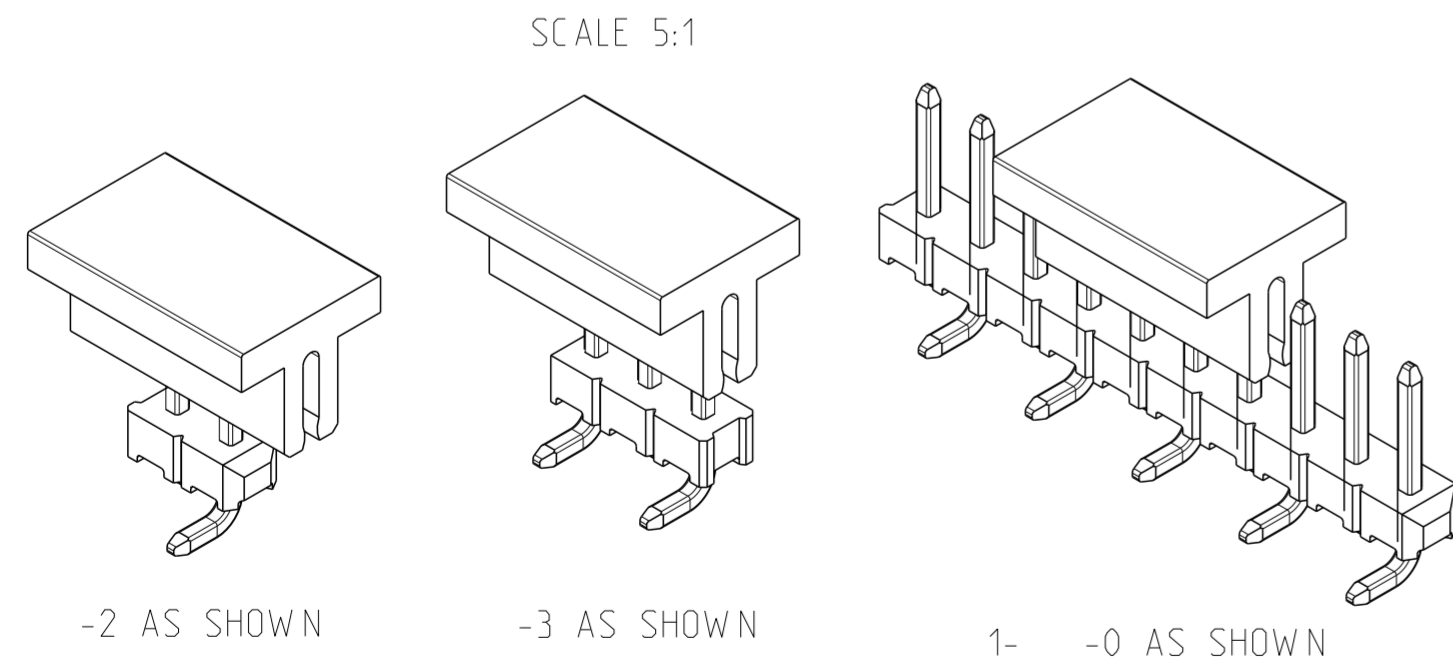
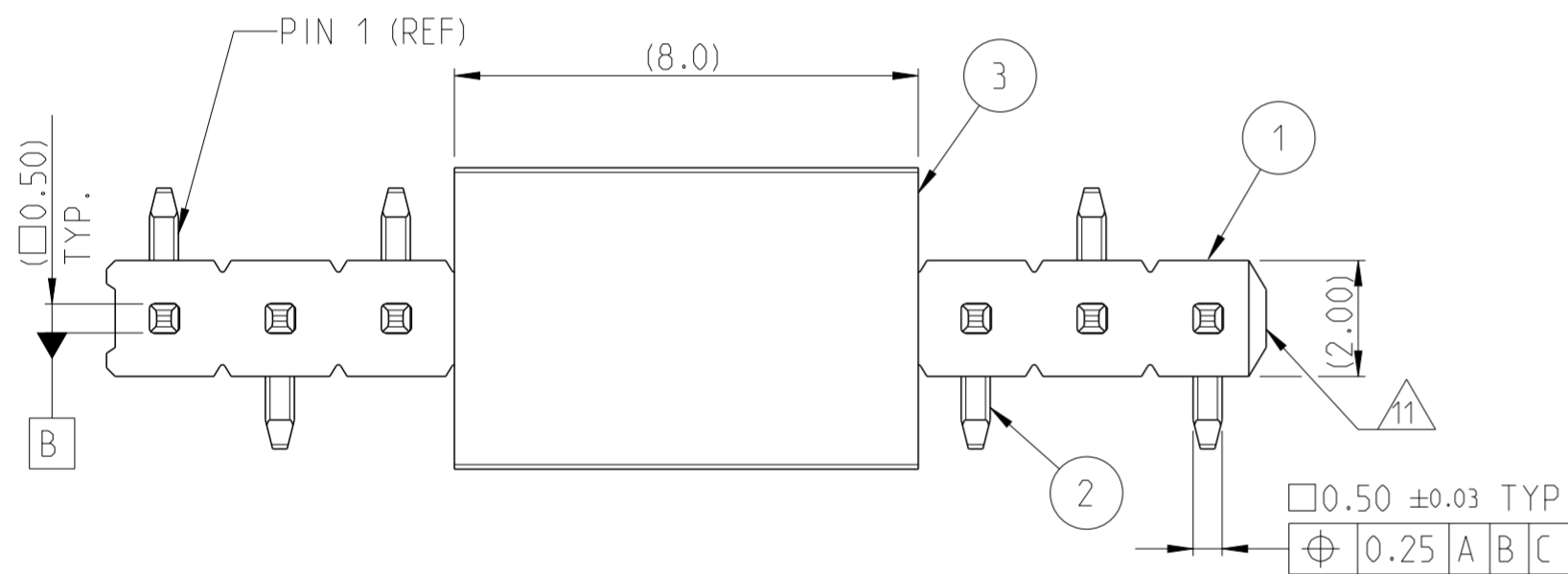

RECOMMENDED PCB LAYOUT

CAP	3
POST	2
HOUSING	1
DESCRIPTION	ITEM NO.

THIS DRAWING IS A CONTROLLED DOCUMENT.		DWN RAKESH 20JUN2016	TE Connectivity			
DIMENSIONS: mm		CHK KARTHIK 20JUN2016				
TOLERANCES UNLESS OTHERWISE SPECIFIED:		APVD PRASHANTH S 20JUN2016				
0 PLC ± 1 PLC ±0.1 2 PLC ±0.05 3 PLC ± 4 PLC ± ANGLES ±2° FINISH		NAME AMPMODU 2mm BREAKAWAY HEADER SINGLE ROW .VERTICAL.SMD PRODUCT SPEC 108-64040 APPLICATION SPEC 114-64040				
MATERIAL SEE NOTES	SEE NOTES	WEIGHT -	SIZE A2	CAGE CODE 00779	DRAWING NO C-2823106	RESTRICTED TO -
CUSTOMER DRAWING			SCALE 8:1	SHEET 1 OF 3	REV A2	

P	LTR	DESCRIPTION	DATE	DWN	APVD
-	-	SEE SHEET 1	-	-	-

SMART PART NUMBER  
 2MM - HB - S \_\_\_ - VS - 00 - \_\_\_ - \_\_\_

PRODUCT SERIES

2MM | AMPMODU 2mm series

GENDER / TYPE

HB | Breakaway headers

NUMBER OF ROWS

S | Single row

NUMBER OF PINS PER ROW

XX | 02 through 25  
(enter two digits)

ORIENTATION & TERMINATION

VS | Vertical surface mount

PACKAGING

TBP	Tube with cap	⚠
TRP	Tape and reel with cap	

PLATING

T	Tin
F	0.1µm selective Gold (Gold flash)
M	0.38µm selective Gold
H	0.76µm selective Gold

TAIL LENGTH

00 | N/A for surface mount

SMART PN EXAMPLES :

1. AMPMODU 2MM, BREAKAWAY HEADER, SINGLE ROW, 04 POSITION PER ROW, SURFACE MOUNT, TAIL LENGTH NOT APPLICABLE, TIN PLATING, TUBE WITH CAP  
 2MM-HB-S04-VS-00-T-TBP
2. AMPMODU 2MM, BREAKAWAY HEADER, SINGLE ROW, 25 POSITION PER ROW, SURFACE MOUNT, TAIL LENGTH NOT APPLICABLE, 0.76µm SELECTIVE GOLD PLATING, TAPE AND REEL WITH CAP  
 2MM-HB-S25-VS-00-H-TRP

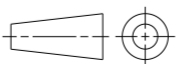
THIS DRAWING IS A CONTROLLED DOCUMENT.		DWN RAKESH 20 JUN 2016	 TE Connectivity	
DIMENSIONS: mm		CHK KARTHIK 20 JUN 2016		
TOLERANCES UNLESS OTHERWISE SPECIFIED:		APVD PRASHANTH S 20 JUN 2016	NAME AMPMODU 2mm BREAKAWAY HEADER SINGLE ROW, VERTICAL, SMD	
		PRODUCT SPEC 108-64040	RESTRICTED TO	
MATERIAL SEE NOTES		APPLICATION SPEC 114-64040	SIZE A2	CAGE CODE 100779
FINISH SEE NOTES		WEIGHT -	DRAWING NO C-2823106	SCALE 1:1
		CUSTOMER DRAWING	SHEET 2 OF 3	REV A2

P	LTR	DESCRIPTION	DATE	DWN	APVD
-	-	SEE SHEET 1	-	-	-

TE INTERNAL BASE NO.	PACKAGING TYPE	MATING SIDE PLATING (FINISH)	SMART PN
<del>2823106</del>	TAPE AND REEL W / CAP	TIN $\triangle$ 2	2MM-HB-SXX-VS-00-T-TRP
<del>2823659</del>	TUBE W / CAP		2MM-HB-SXX-VS-00-T-TBP
2823107	TAPE AND REEL W / CAP	SELECTIVE Au FLASH 0.1 $\mu$ m $\triangle$ 3	2MM-HB-SXX-VS-00-F-TRP
2823660	TUBE W / CAP		2MM-HB-SXX-VS-00-F-TBP
2823108	TAPE AND REEL W / CAP	SELECTIVE Au 0.38 $\mu$ m $\triangle$ 4	2MM-HB-SXX-VS-00-M-TRP
2823661	TUBE W / CAP		2MM-HB-SXX-VS-00-M-TBP
2823109	TAPE AND REEL W / CAP	SELECTIVE Au 0.76 $\mu$ m $\triangle$ 5	2MM-HB-SXX-VS-00-H-TRP
2823662	TUBE W / CAP		2MM-HB-SXX-VS-00-H-TBP

48.0	50.0	25	2-	-5
46.0	48.0	24	2-	-4
44.0	46.0	23	2-	-3
42.0	44.0	22	2-	-2
40.0	42.0	21	2-	-1
38.0	40.0	20	2-	-0
36.0	38.0	19	1-	-9
34.0	36.0	18	1-	-8
32.0	34.0	17	1-	-7
30.0	32.0	16	1-	-6
28.0	30.0	15	1-	-5
26.0	28.0	14	1-	-4
24.0	26.0	13	1-	-3
22.0	24.0	12	1-	-2
20.0	22.0	11	1-	-1
18.0	20.0	10	1-	-0
16.0	18.0	9		-9
14.0	16.0	8		-8
12.0	14.0	7		-7
10.0	12.0	6		-6
8.0	10.0	5		-5
6.0	8.0	4		-4
4.0	6.0	3		-3
2.0	4.0	2		-2
DIM "F"	DIM "E"	NUMBER OF PINS PER ROW "XX"	TE INTERNAL PART NO.	

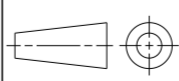
THIS DRAWING IS A CONTROLLED DOCUMENT.		DWN RAKESH 20 JUN 2016	 TE Connectivity		
DIMENSIONS: mm		CHK KARTHIK 20 JUN 2016			
TOLERANCES UNLESS OTHERWISE SPECIFIED:		APVD PRASHANTH S 20 JUN 2016	NAME AMPMODU 2mm BREAKAWAY HEADER SINGLE ROW .VERTICAL.SMD		
		PRODUCT SPEC 108-64040	RESTRICTED TO		
MATERIAL SEE NOTES		APPLICATION SPEC 114-64040	SIZE A2	CAGE CODE 00779	DRAWING NO C-2823106
FINISH SEE NOTES		WEIGHT -	SCALE 8:1	SHEET 3 OF 3	REV A2
CUSTOMER DRAWING					