

- NOTES:
- 1) MATERIAL: UNFILLED NYLON, RATED UL94V-2, IEC60335-1 GLOW WIRE CAPABLE, COLOR: NATURAL(WHITE).
  - 2) FINISH: NONE
  - 3) PRODUCT SPECIFICATION: PS-43045
  - 4) PACKAGING SPECIFICATION: BULK PER 1729530001-PK
  - 5) FOR USE WITH: 172952-XX02 RECEPTACLE OR 203632-XX1X PLUG HOUSINGS. NEVER USE WITHOUT TPA.
  - 6) THIS PART CONFORMS TO CLASS B REQUIREMENTS OF COSMETIC SPEC PS-45499-002
  - 7) TEXT ON PART IS FOR REFERENCE ONLY. TEXT AND TEXT LOCATION MAY VARY DEPENDING ON PART NUMBER AND/OR TOOL.
  - 8 BOW 0.38 / .015 MAX PER 25.4 / 1.00 ON SURFACE C
  - 9 CIRCUIT SIZE INDICATES THE SIZE OF THE MATCHING DUAL-ROW RECEPTACLE HOUSING. TWO TPA STRAPS ARE REQUIRED FOR EACH RECEPTACLE HOUSING.
  - 10) SEE SD-172952-002 (RECEPTACLE) OR 2036320010-SD (PLUG) FOR INSTALLATION INSTRUCTIONS

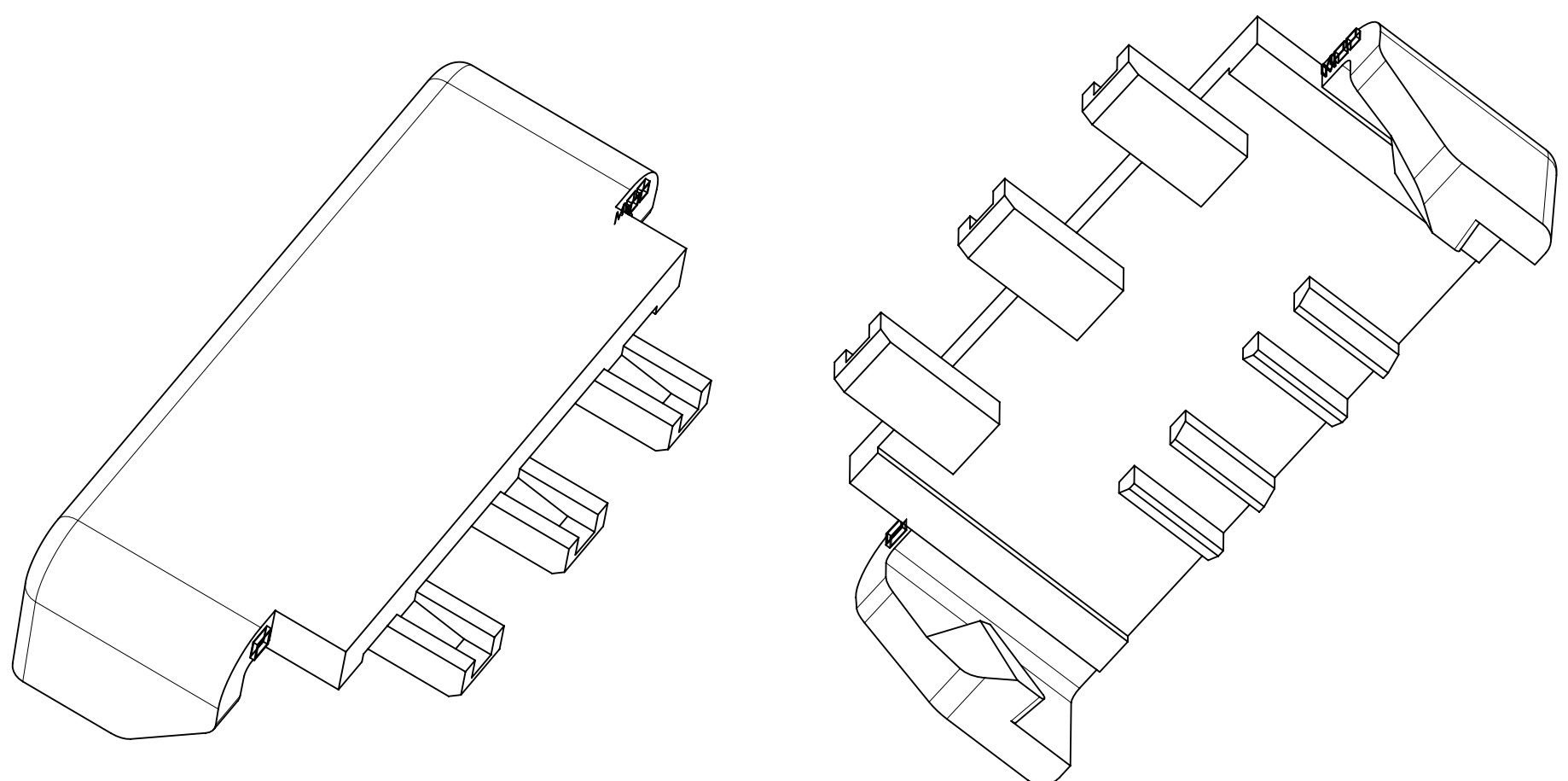

24	172953-2402	39.70 / 1.563	37.05 / 1.459
22	172953-2202	36.70 / 1.445	34.05 / 1.341
20	172953-2002	33.70 / 1.327	31.05 / 1.222
18	172953-1802	30.70 / 1.209	28.05 / 1.104
16	172953-1602	27.70 / 1.091	25.05 / .986
14	172953-1402	24.70 / .973	22.05 / .868
12	172953-1202	21.70 / .854	19.05 / .750
10	172953-1002	18.70 / .736	16.05 / .632
8	172953-0802	15.70 / .618	13.05 / .514
6	172953-0602	12.70 / .500	10.05 / .396
4	172953-0402	9.70 / .382	7.05 / .278
CKT SIZE 9	PART NUMBER	DIM A ±0.51/±.020	DIM B +0.65/-0.38 +0.026/-.015

THIS DRAWING CONTAINS INFORMATION THAT IS PROPRIETARY TO MOLEX ELECTRONIC TECHNOLOGIES, LLC AND SHOULD NOT BE USED WITHOUT WRITTEN PERMISSION

DIMENSION UNITS	SCALE	CURRENT REV DESC:	
MM/IN	10:1		
GENERAL TOLERANCES (UNLESS SPECIFIED)		EC NO: 793990	
4 PLACES ±	±	DRWN: ZIXUAG	2024/08/06
3 PLACES ±	± 0.01	CHK'D: XQZHANG	2024/12/13
2 PLACES ±	± 0.25 ± 0.015	APPR: XQZHANG	2024/12/13
1 PLACE ±	± 0.38 ±	INITIAL REVISION:	
0 PLACES ±	±	DRWN: MCOLE	2016/02/24
ANGULAR TOL ± 0.5 °		APPR: BPISZCZOR	2016/03/24
DRAFT WHERE APPLICABLE MUST REMAIN WITHIN DIMENSIONS	THIRD ANGLE PROJECTION	DRAWING	SERIES
		C-SIZE	172953

<b>molex</b>			
MICRO-FIT DUAL ROW TPA GLOW WIRE FOR RECEPTACLE AND PLUG HOUSINGS			
PRODUCT CUSTOMER DRAWING			
DOCUMENT NUMBER	DOC TYPE	DOC PART	REVISION
SD-172953-002	PSD	001	B1
MATERIAL NUMBER	CUSTOMER	SHEET NUMBER	
SEE CHART	GENERAL MARKET	1 OF 1	