

REVISIONS				
P	LTR	DESCRIPTION	DATE	APVD
P		REVISED PER ECR-26-271876	26MAR2026	MA JFS

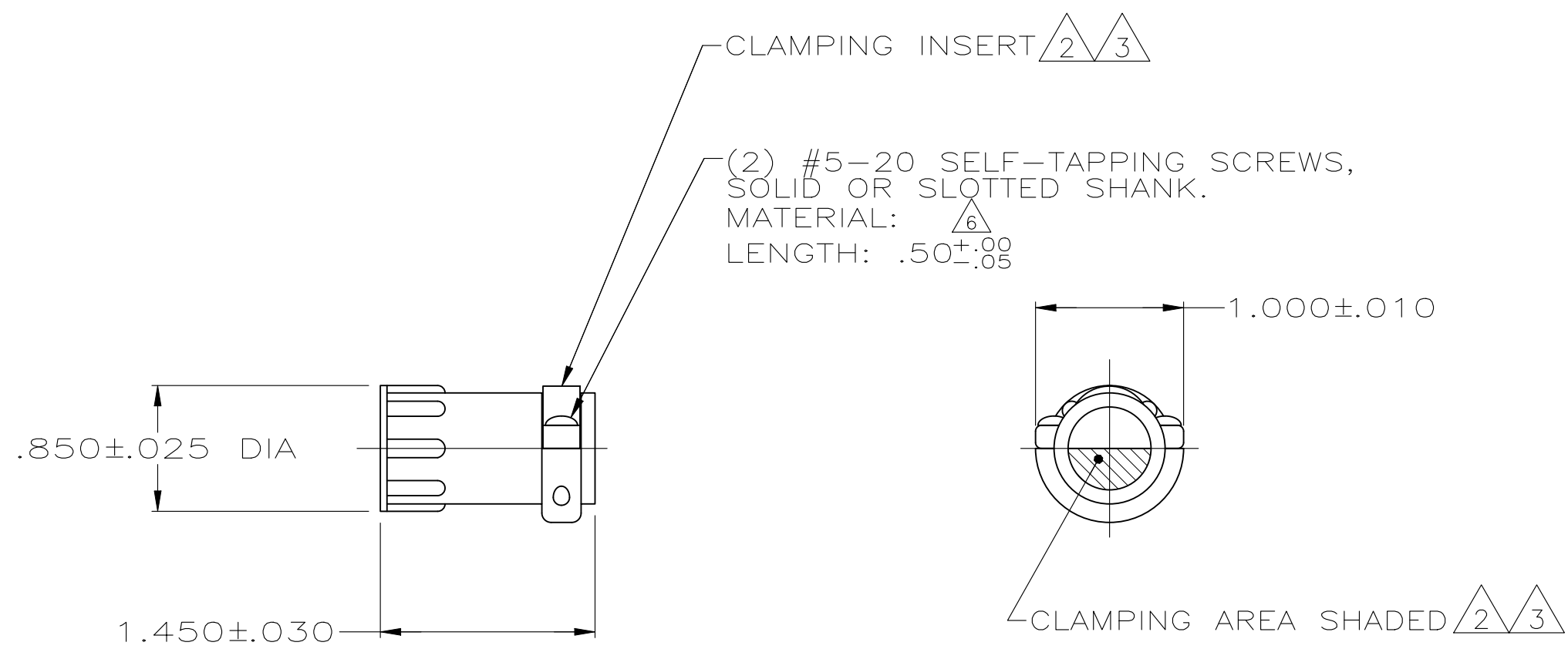

1 PARTS PACKAGED UNASSEMBLED.

$\triangle 2$ CABLE CLAMPING AREA ADJUSTABLE FROM .010 TO .161 SQ IN BY REVERSING CLAMPING INSERTS. (2 INSERTS SUPPLIED, -1 AND -2 ONLY)

$\triangle 3$ CABLE CLAMPING AREA ADJUSTABLE FROM .010 TO .161 SQ IN BY CHANGING CLAMPING INSERTS. (4 INSERTS SUPPLIED, -3 ONLY)

4 .453 MAXIMUM CABLE OUTSIDE DIAMETER.

$\triangle 5$ BULK PACKAGED KITS TO BE ORDERED IN MULTIPLES OF 200 ONLY.

$\triangle 6$ STEEL, ZINC PLATE WITH NON-HEXAVALENT CHROMATE.

$\triangle 6$	$\triangle 5$	BULK	206358-6
$\triangle 6$		INDIVIDUAL	206358-5
$\triangle 6$		INDIVIDUAL	206358-4
	OBSOLETE	$\triangle 5$ BULK	206358-3
$\triangle 6$	SUPERSEDED BY 206358-6	$\triangle 5$ BULK	206358-2
$\triangle 6$	SUPERSEDED BY 206358-5	INDIVIDUAL	206358-1
		PACKAGING	PART NUMBER

THIS DRAWING IS A CONTROLLED DOCUMENT.		DWN A GRAFF 4/23/91	STE TE Connectivity													
DIMENSIONS: INCHES		CHK W.G.LENKER 7-23-92														
TOLERANCES UNLESS OTHERWISE SPECIFIED:		APVD -	NAME CABLE CLAMP KIT, LARGE, SHELL SIZE 11, CPC													
<table border="0"> <tr><td>0 PLC</td><td>± -</td></tr> <tr><td>1 PLC</td><td>± -</td></tr> <tr><td>2 PLC</td><td>± -</td></tr> <tr><td>3 PLC</td><td>± -</td></tr> <tr><td>4 PLC</td><td>± -</td></tr> <tr><td>ANGLES</td><td>± -</td></tr> </table>		0 PLC	± -	1 PLC	± -	2 PLC	± -	3 PLC	± -	4 PLC	± -	ANGLES	± -	PRODUCT SPEC 108-10024	RESTRICTED TO -	
0 PLC	± -															
1 PLC	± -															
2 PLC	± -															
3 PLC	± -															
4 PLC	± -															
ANGLES	± -															
MATERIAL THERMOPLASTIC		FINISH -	APPLICATION SPEC -	SCALE NTS												
		WEIGHT -	SIZE A3	CAGE CODE 00779												
		CUSTOMER DRAWING	DRAWING NO C-206358	SHEET 1 OF 1												
			REV P													