

PART NUMBER	ITEM ① INTERFACE INSERT	ITEM ② BASE	ITEM ③ CONTACT	ITEM ④ INSULATOR
127-0701-811	BERYLLIUM COPPER GOLD PL .00005 MIN OVER NICKEL PL .00005 MIN OVER COPPER PL	BRASS GOLD PL .00001 MIN OVER NICKEL PL .00005 MIN OVER COPPER PL	BERYLLIUM COPPER GOLD PL .00005 MIN OVER NICKEL PL .00005 MIN OVER COPPER PL	TEFLON

REV	ECO	DATE
1	INITIAL RELEASE	29APR2020

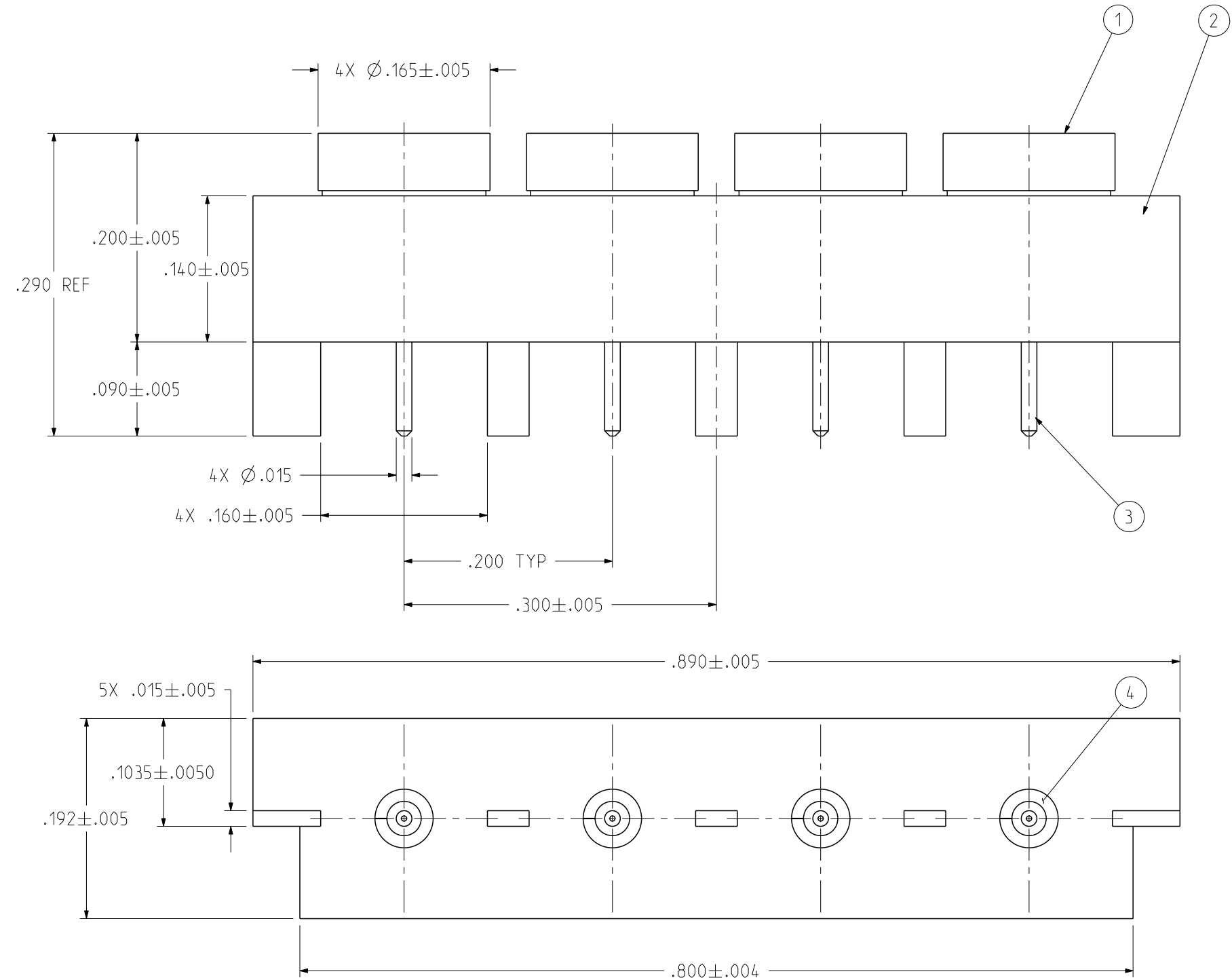
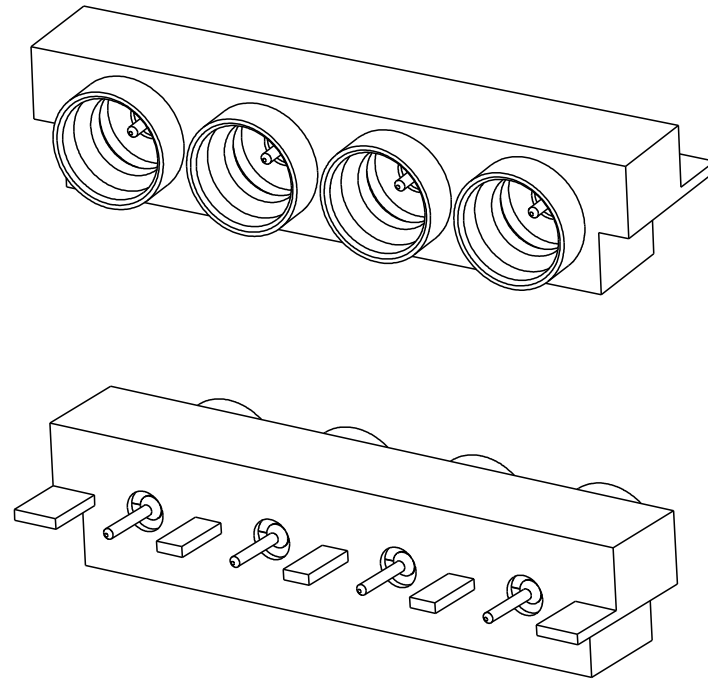

NOTES:

1. ELECTRICAL SPECIFICATIONS:

- 1.1 IMPEDANCE: 50 OHMS NOMINAL
- 1.2 FREQUENCY RANGE: DC-40 GHz
- 1.3 VSWR: 1.15 MAX TO 26.5 GHz, 1.50 MAX TO 40 GHz
- 1.4 WORKING VOLTAGE: 335 VRMS MAX AT SEA LEVEL
- 1.5 DIELECTRIC WITHSTANDING VOLTAGE: 500 VRMS MIN AT SEA LEVEL
- 1.6 INSULATION RESISTANCE: 5000 MEGOHM MIN
- 1.7 CONTACT RESISTANCE:
 - 1.7.1 CENTER CONTACT - INITIAL 6.0 MILLIOHM MAX, AFTER ENVIRONMENTAL NOT APPLICABLE
 - 1.7.2 OUTER CONDUCTOR - INITIAL 2.0 MILLIOHM MAX, AFTER ENVIRONMENTAL NOT APPLICABLE
- 1.8 INSERTION LOSS: $0.06\sqrt{F}$ (GHz) dB MAX
- 1.9 CORONA LEVEL: 190 VOLTS MINIMUM AT 70,000 FEET
- 1.10 RF HIGH POTENTIAL WITHSTANDING VOLTAGE: 325 VRMS MIN AT 4 AND 7 MHz

2. MECHANICAL SPECIFICATIONS:

- 2.1 INTERFACE DESIGN: IN ACCORDANCE WITH MIL-STD-348, SERIES SMP
- 2.2 ENGAGEMENT FORCE: 15 LBS MAX (FULL DETENT)
- 2.3 DISENGAGEMENT FORCE: 5 LBS MIN (FULL DETENT)
- 2.4 DURABILITY: 100 CYCLES MIN (FULL DETENT)

3. ENVIRONMENTAL:

- 3.1 OPERATING TEMPERATURE: -65 °C TO 165 °C
- 3.2 THERMAL SHOCK: MIL-STD-202, METHOD 107, CONDITION B, EXCEPT 165°C HIGH TEMP
- 3.3 MECHANICAL SHOCK: MIL-STD-202, METHOD 213, CONDITION I
- 3.4 CORROSION: MIL-STD-202, METHOD 101, CONDITION B
- 3.5 VIBRATION: MIL-STD-202, METHOD 204, CONDITION D
- 3.6 MOISTURE RESISTANCE: MIL-STD-202, METHOD 106, EXCEPT STEP 7B OMITTED

	Model No: 127-0701-811/820	JOHNSON	
	RoHS <input checked="" type="checkbox"/> (EU)/2015/863 COMPLIANT	Cage Code	Title: SMP MALE FULL DETENT 4-PORT PCB EDGE MOUNT
<small>UNLESS OTHERWISE SPECIFIED UNITS: INCH</small> .XX ± .01 .XXX ± .003 .XXXX ± .0010 ANGLE ± 2°	3RD ANGLE PROJECTION	Drawing No. 127-0701-811/820	REV. 1
	Drawn by: TOMMY REN	Date: 04/29/2020	Size B
<small>INTERPRET DRAWING IN ACCORDANCE WITH ASME Y14.5-2009.</small>	DO NOT SCALE DRAWING	Workmanship Std:Sheet NONE	1 OF 1