

| REVISIONS | | | | | |
|-----------|-----|---------------------------|-----------|-----|------|
| P | LTR | DESCRIPTION | DATE | DWN | APVD |
| E | | REVISED PER ECR-25-250800 | 03JAN2025 | F.Z | R.B |

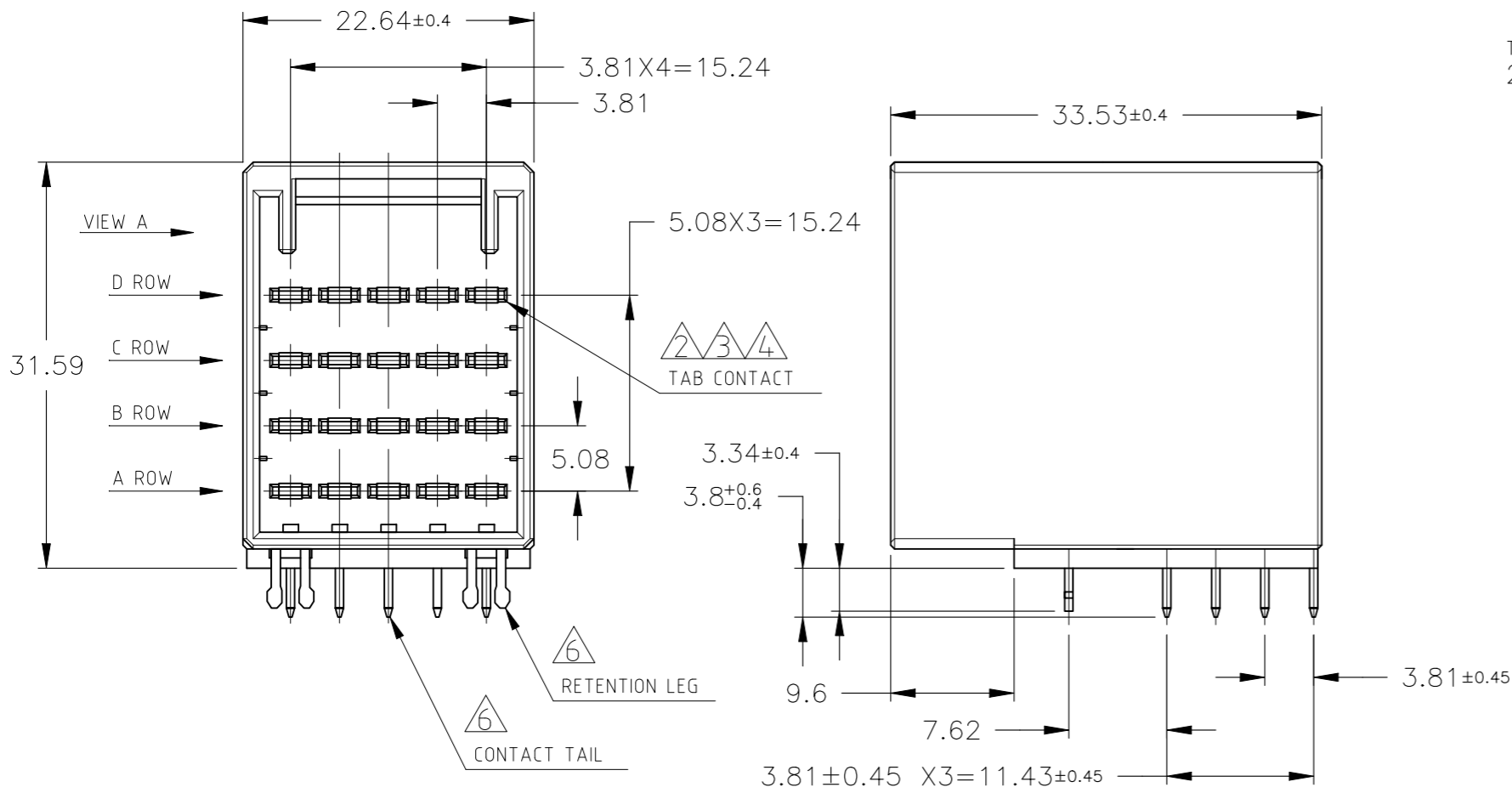

- NOTES:
- △ MATERIAL
HOUSING: GLASS FIELD POLYESTER
CONTACT: COPPER ALLOY
RETENTION LEG: COPPER ARROY
 - △ FINISH (CONTACT AREA): 0.38µm PdNi & Au PLATING OVER NICKEL
 - △ FINISH (CONTACT AREA): 0.76µm PdNi & Au PLATING OVER NICKEL
 - △ FINISH (CONTACT ALL AREA): 2.0µm MIN TIN PLATING OVER NICKEL
 - △ FINISH (RETENTION LEG AND CONTACT TAIL): TIN-LEAD PLATING
 - △ FINISH (RETENTION LEG AND CONTACT TAIL): TIN PLATING OVER NICKEL

RECOMMEND PC BOARD HOLE PATTERN
(NOT ACCUMULATE TOLERANCE)
PC BOARD THICKNESS : 1.6±0.1

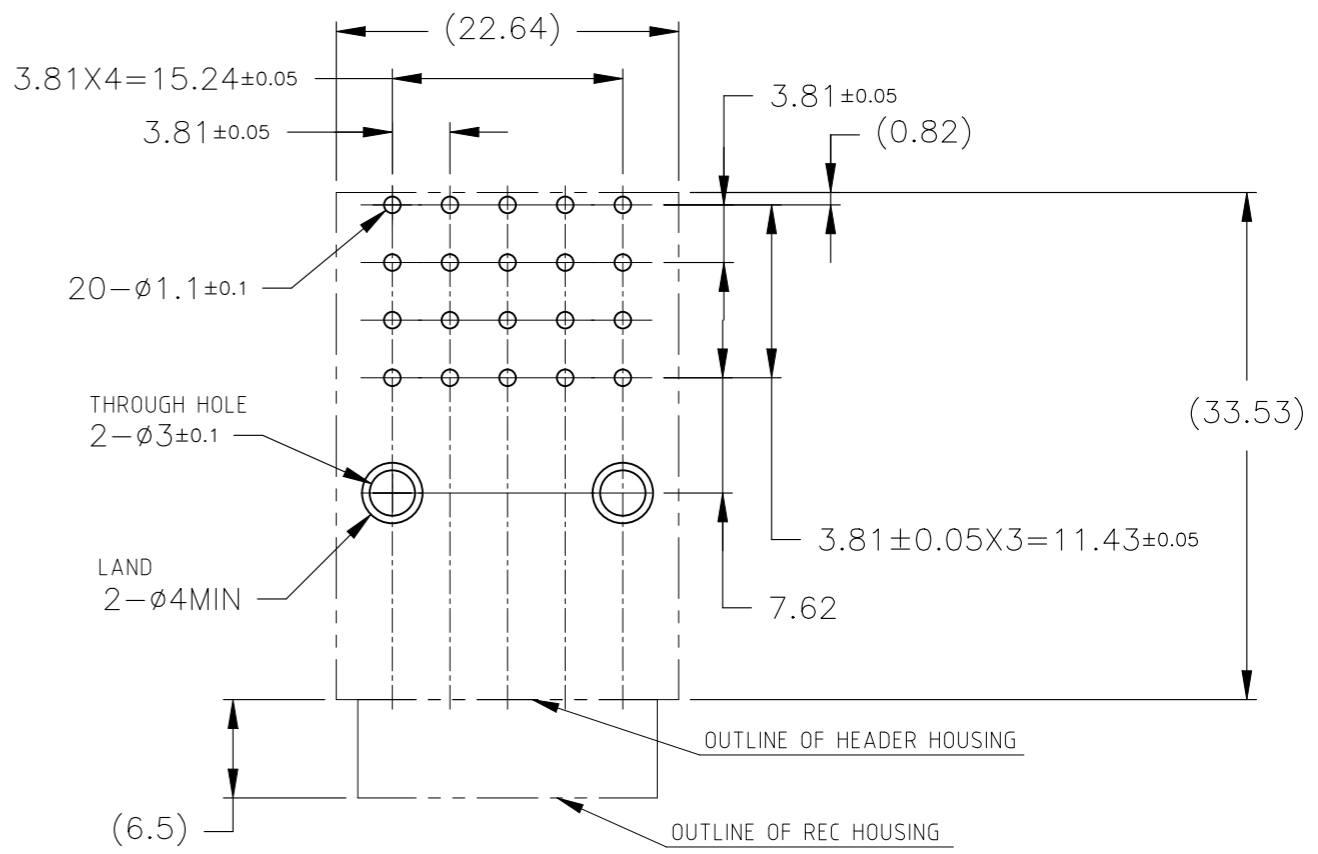
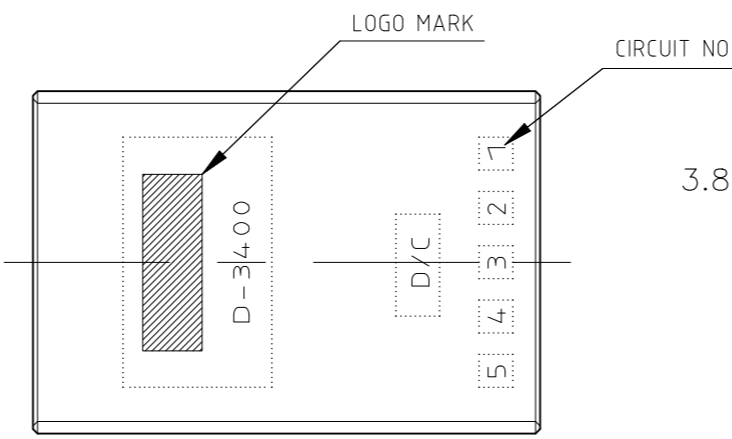
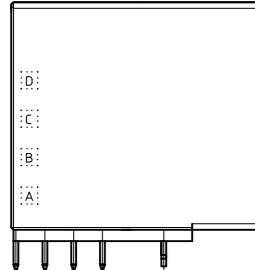

| | | | |
|--------|---------|--------------|------|
| △6 | △2 | 9-917251-2 | TRAY |
| △6 | △4 | 917251-5 | TUBE |
| △6 | △3 | 917251-3 | TUBE |
| △6 | △2 | 917251-2 | TUBE |
| FINISH | PART NO | PACKING TYPE | |

| | | | | | | |
|---|--|----------------------------------|-----------------------------------|-----------------|------------|---------------|
| THIS DRAWING IS A CONTROLLED DOCUMENT. | | DWN H.OSABE 02JUN2022 | TE Connectivity | | | |
| DIMENSIONS: mm | | CHK T.SHIMOYASU 02JUN2022 | | | | |
| TOLERANCES UNLESS OTHERWISE SPECIFIED: | | APVD T.SHIMOYASU 02JUN2022 | NAME | | | |
| 0-PLC ± - 1-PLC ± LESS 10 ; ±0.3 2-PLC ± -10 ; ±30 ; ±0.4 3-PLC ± -30 ; ±100 ; ±0.45 4-PLC ± - ANGLES ± 3° | | PRODUCT SPEC 108-5349 | DYNAMIC D-3400 20P(H) HDR ASSY | | | |
| MATERIAL SEE NOTE | | APPLICATION SPEC - | SIZE | CAGE CODE | DRAWING NO | RESTRICTED TO |
| FINISH SEE NOTE | | WEIGHT 18.45g | A3 | 00779 | C-917251 | - |
| CUSTOMER DRAWING | | | SCALE 2:1 | SHEET 1 OF 1 | REV E | |