



DYNAMIC CONNECTOR D-5000 SERIES

1. SCOPE

1.1. Content

This specification covers the requirements for product performance, test methods and quality assurance provisions of Dynamic connector D-5000 series.

2. APPLICABLE DOCUMENTS AND FORMS

The following documents and forms constitute a part of this specification to the extent specified herein. Unless otherwise indicated, the latest edition of the document applies.

2.1. TE Documents

- 114-5206: Application Specification
- 501-5188: Qualification Test Report
- 501-162547: Qualification Test Report For contact plating with PdNi & Gold Flash

2.2. Industry Documents

- MIL-STD-202: Test methods for Electronics And Electrical Component Parts
- EIA364: Electrical Connector / Socket Test Procedures Including Environmental Classifications

2.3. Reference Document

- 109-197 Test Specification (TE Test Specification vs EIA and IEC Test Methods)

3. REQUIREMENTS

3.1. Design and Construction

Product shall be of the design, construction, materials and physical dimensions specified on the applicable product drawing.

3.2. Materials

- Contact

- (1) Material: Copper Alloy

- (2) Finish: Receptacle: Nickel plating all over

- Gold plating or PdNi &Gold Flash (Contact area)

- or Silver plating (all over)

- Tab (Header): Nickel plating all over

- Gold plating or PdNi &Gold Flash (Contact area) (Contact area)

- and Tin plating (tine area)

- Or Silver plating (all over)

- Tab (wire): Nickel plating all over

- Gold plating PdNi &Gold Flash (Contact area) (Contact area)

- or Silver plating (all over)

- Housing

- (1) Material: G.F. Thermoplastic

- (2) Flammability: UL94 V-0

- Accessories and hardware (retention leg)
 - (1) Material: Copper alloy
 - (2) Finish: Tin plating

3.3. Ratings

Voltage	Current	Temperature
630V AC/DC	Figure 1,2,3 Derating curve is paragraph 6	-55°C to 105°C Included temperature rising by energized current

- Ambient temperature: 75°C, Temperature rising: 30°C

Series Plating: Gold or PdNi &Gold flash	Position	Current Rating						
		AWG 8	AWG 10	AWG 12	AWG 14	AWG 16	AWG 18	AWG 20
D5200	2	39	33	27	21	17	13	11
	3	38	32	26	20	17	12	10
	4	36	32	25	19	16	11	10
	6	35	30	25	19	16	10	9
	8	33	28	23	17	14	10	9
D5300	3	35	30	25	20	16	11	9
	4	35	30	25	19	16	10	9
D5200alpha	3	-	-	-	-	-	-	-
	4	35	31	25	20	17	14	12

Series Plating: Ag	Type	Position	Current Rating						
			AWG 8	AWG 10	AWG 12	AWG 14	AWG 16	AWG 18	AWG 20
D5200	WTB	4	42	34	27	22	18	14	11
	WTW	2	46	36	29	26	21	17	12
		3	44	35	29	24	20	15	11
		4	43	34	28	24	17	15	11
		6	39	30	22	20	16	12	10
D5300	WTW	3	38	31	26	20	16	12	10
		4	36	30	25	19	16	12	10
D5200alpha	WTB	3	45	38	33	25	20	16	12
		4	43	35	31	23	18	15	12

Figure 1

- Ambient temperature: 40°C, Temperature rising: 65°C

Series Plating: Gold or PdNi &Gold flash	Position	Current Rating						
		AWG 8	AWG 10	AWG 12	AWG 14	AWG 16	AWG 18	AWG 20
D5200	2	53	44	36	29	23	20	15
	3	52	43	34	27	22	17	14
	4	48	43	32	25	21	17	14
	6	45	37	32	24	20	16	13
	8	43	35	30	23	19	15	12
D5300	3	46	38	34	27	22	16	13
	4	44	39	32	27	21	16	13
D5200alpha	3	-	-	-	-	-	-	-
	4	46	41	37	30	26	20	19

Series Plating: Ag	Type	Position	Current Rating						
			AWG 8	AWG 10	AWG 12	AWG 14	AWG 16	AWG 18	AWG 20
D5200	WTB	4	56	49	38	30	26	21	16
		2	66	51	42	35	28	24	18
	WTW	3	62	49	41	33	28	20	16
		4	60	49	40	33	24	20	16
		6	52	41	31	28	23	17	14
D5300	WTW	3	53	42	37	27	22	17	14
		4	50	42	33	27	22	17	14
D5200alpha	WTB	3	-	-	-	-	-	-	-
		4	57	45	36	31	25	20	17

Figure 2

- Ambient temperature: 25°C, Temperature rising: 80°C

Series Plating: Gold or PdNi & Gold flash	Position	Current Rating						
		AWG 8	AWG 10	AWG 12	AWG 14	AWG 16	AWG 18	AWG 20
D5200	2	60	48	40	32	25	22	17
	3	58	48	38	30	25	19	15
	4	53	48	36	28	24	19	15
	6	50	41	35	27	22	17	14
	8	48	39	33	25	21	16	14
D5300	3	51	43	38	30	24	17	14
	4	49	43	36	30	24	18	14
D5200alpha	3	-	-	-	-	-	-	-
	4	51	46	41	34	29	23	21

Series Plating: Ag	Type	Position	Current Rating						
			AWG 8	AWG 10	AWG 12	AWG 14	AWG 16	AWG 18	AWG 20
D5200	WTB	4	63	56	43	34	29	23	18
		2	74	57	48	39	32	26	20
	WTW	3	69	56	46	36	32	22	18
		4	67	55	44	37	27	23	18
		6	57	46	35	31	26	19	16
D5300	WTW	3	59	47	41	30	24	19	15
		4	56	47	36	30	25	19	15
D5200alpha	WTB	3	-	-	-	-	-	-	-
		4	63	50	41	34	28	22	19

Figure 3

3.4. Performance Requirements and Test Descriptions

The product shall be designed to meet the electrical, mechanical and environmental performance requirements specified in Figure 4. All tests shall be performed in the room temperature, unless otherwise specified.

3.5. Test Requirements and Procedures Summary

Para	TEST DESCRIPTION	REQUIREMENT	PROCEDURE		
3.5.1	Examination of product	Meets requirements of product drawing.	Visual inspection No physical damage.		
ELECTRICAL					
3.5.2	Contact Resistance (Low Level)	2mΩMax	Subject mated contacts assembled in housing to 50mV Max open circuit at 50mA. Refer to Figure 6 EIA364-23		
3.5.3	Dielectric withstanding Voltage	No creeping discharge or flashover shall occur. Current leakage: 0.5 mA Max.	3kVAC for 1 minute. Test between adjacent circuits of mated/unmated connectors. MIL-STD-202 Method 301		
3.5.4	Insulation Resistance	1000MΩ Min	Impressed voltage 500 V DC. Test between adjacent circuits of mated/unmated connectors. MIL-STD-202 Method 302 condition B		
3.5.5	Temperature Rising	Temperature rising: specified value Max. Under loaded specified current. Refer Figure 1,2,3	Measure temperature rising by energized current. Refer to Figure 7 EIA364-70		
MECHANICAL					
3.5.6	Contact Retention Force	49N Min.	Apply an axial pull-off load to crimped wire. Operation Speed: 100mm/min. EIA364-29		
3.5.7	Crimp Tensile Strength	Wire Size		Crimp Tensile (Min.) N Apply an axial pull-off load to crimped wire of contact secured on the tester. Operation Speed: 25 mm/min. EIA364-8	
		mm ²	(AWG)		
		0.50	#20		73.5
		0.85	#18		117
		1.309	#16		186
		2.081	#14		245
		3.309	#12		313
		5.262	#10		401
8	#8	401			
3.5.8	Physical Shock	No electrical discontinuity greater than 1μsec. Shall occur. Meet requirement of Contact resistance (2mΩ Max.)	Accelerated Velocity :490m/s ² Waveform: sine wave Duration: 11ms Velocity Change: 3.4m/s Number of Drops:3 drops each to normal and reversed directions of X, Y and Z axes, totally 18 drops MIL-STD-202 Method 213, condition A		
3.5.9	Connector Mating Force	9.8N Max per 1 contact (Initial) Silver plated product: 19.6N Max per 1 contact (Initial)	Operation Speed: 100mm/min. Measure the force required to mate connector. EIA364-13		

3.5.10	Connector Unmating Force	1.96N – 19.6N per 1 contact (Initial)	Operation Speed: 100mm/min. Measure the force required to unmate connector. EIA364-13
3.5.11	Contact Insertion Force	9.8N Max per 1 contact	Measure the force required to insert contact into housing.
3.5.12	Vibration (High Frequency)	No electrical discontinuity greater than 1µsec. Shall occur.	Vibration Frequency: 10-500 / 15min. Accelerated Velocity: 98 m/s ² Vibration Direction: X, Y, Z Duration: 2 hours each MIL-STD-202 Method 204 condition A
3.5.13	Durability (Repeated Mate/Unmating)	Meet requirement of Contact resistance (2mΩ Max.).	Operation Speed: 100mm/min No. of cycles: Gold or PdNi & Gold flash (0.38µm):25 Gold or PdNi & Gold flash (0.76µm):50 Silver(2.54µm):25 EIA364-9
3.5.14	Housing Locking Strength	98N Min.	Measure housing locking strength. Operation Speed: 50 mm/min. EIA364-98
3.5.15	Solderability	Wet Solder Coverage: 95% Min.	Solder Temperature: 235 ± 5°C Immersion Duration: 5 ± 0.5seconds Flux: Alpha 100 MIL-STD-202 Method 208

ENVIRONMENTAL

3.5.16	Resistance to soldering Heat	No physical damage shall occur.	Test connector on PCB. Solder Temperature:260 ± 5°C Immersion Duration: 10 ± 1sec MIL-STD-202 Method 210A, condition B
3.5.17	Thermal Shock	Meet requirement of Contact resistance (2mΩ Max).	Mated connector –55°C / 30min., 85°C / 30min. Making this a cycle, repeat 25 cycles. MIL-STD-202 Method 107, condition A-1
3.5.18	Humidity-Temperature Cycling	Meet requirement of Contact resistance (2mΩ Max).	Mated/Unmated connector, 25~65°C, 90~95% R.H. 10 cycles Cold shock –10°C not performed MIL-STD-202 Method 106
3.5.19	Industrial Gas (SO ₂)	Meet requirement of Contact resistance (2mΩ Max).	Gold or PdNi & Gold flash Plating only Mated connector SO ₂ Gas: 10ppm, 95% R.H. 25 °C, 96 hours
3.5.20	Temperature Life (Heat Aging)	Meet requirement of Contact resistance (2mΩ Max).	Mated connector 105 °C, Duration: 250hours MIL-STD-202 Method 108
3.5.21	Industrial gas (H ₂ S)	Meet requirement of Contact resistance (2mΩ Max).	Silver Plating only Mated connector H ₂ S Gas: 10ppm, 95% R.H. 25 °C, 504 hours JIS spec C 0092



NOTE

Shall meet visual requirements, show no physical damage, and meet requirements of additional tests as specified in the Product Qualification and Requalification Test Sequence shown in Figure 5.

Figure 4

4. PRODUCT QUALIFICATION AND REQUALIFICATION TEST SEQUENCE

TEST OR EXAMINATION	TEST GROUP											
	1	2	3	4(b)	5	6	7	8	9	10	11	12(c)
	TEST SEQUENCE (a)											
Examination of product	1	1	1	1	1	1	1	1	1	1	1	1
Contact Resistance (Low Level)		2,5	2,4,6 8,10	2,5								2,5
Dielectric Withstanding Voltage						3,6						
Insulation Resistance						2,5						
Temperature Rising					2							
Vibration		3										
Physical Shock		4										
Conn. Mating Force	2,5											
Conn. Unmating Force	3,6											
Conn. Locking Strength							2					
Cont. Insertion Force								2				
Cont. Retention Force								3				
Crimp Tensile Strength									2			
Durability (Repeated Mate/Unmating)	4		3	3								3
Solderability										2		
Resistance to Soldering heat											2	
Thermal Shock			7									
Humidity-Temperature Cycling			9			4						
Industrial SO ₂ gas				4								
Temperature Life			5									
Industrial H ₂ S gas												4



NOTE

- (a) Numbers indicate sequence in which tests are performed.
- (b) Gold plating only
- (c) Silver plating only

Figure 5

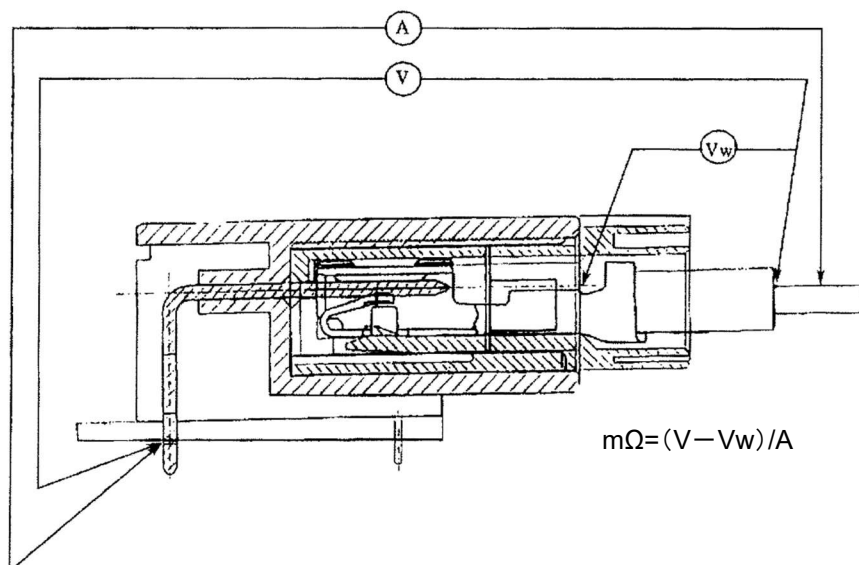
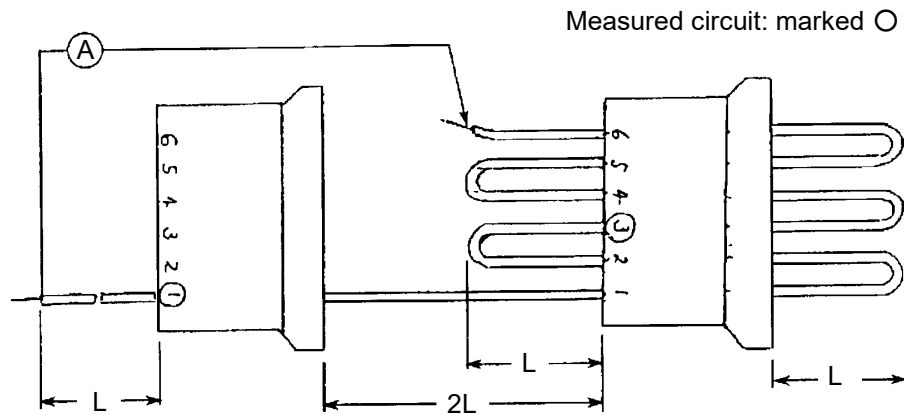

Figure 6: Measurement of contact resistance



WIRE	L
AWG#8	57cm
AWG#10	50cm
AWG#12	42cm
AWG#14	36cm
AWG#16	29cm
AWG#18	25cm
AWG#20	20cm

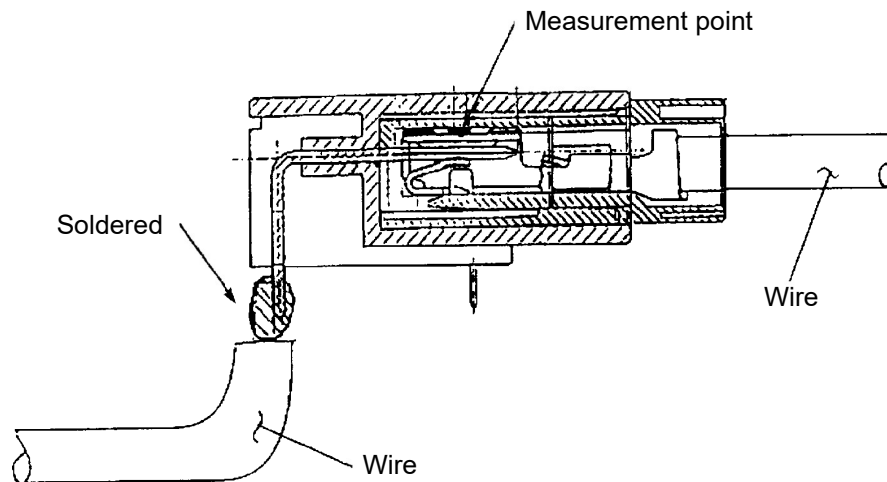

Figure 7: Measurement of Temperature rising

5. REQUIREMENTS:

5.1. Qualification Testing

- Sample Selection

Connector housings and contacts shall be prepared in accordance with applicable Instruction Sheets. They shall be selected at random from current production.

- Test Sequence

Qualification inspection shall be verified by Testing samples as specified in Figure 5.

- Test conditions

Unless otherwise specified, all the tests shall be performed in any combination of the test condition

Temperature	15-35°C
Relative humidity	45-75%
Atmospheric Pressure	866.6-1066.6hPa

5.2. Requalification Testing

If changes significantly affecting form, fit or function are made to the product or to the manufacturing process, product assurance shall coordinate requalification testing, consisting of all or part of the original testing sequence as determined by envelopment product, quality and reliability engineering.

5.3. Acceptance

Acceptance is based on verification that the product meets the requirements of Figure.4. Failures attributed to equipment, test get up, or operator deficiencies shall not disqualify the product. When product failure occurs, corrective action shall be taken and samples resubmitted for qualification. Testing to confirm corrective action is required before resubmittal.

5.4. Quality Conformance Inspection

The applicable TE quality inspection plan will specify the sampling acceptable quality level to be used. Dimensional and functional requirements shall be in accordance with the applicable product drawing and this specification.

6. DERATING CURVE (REFERENCE, DERATING FACTOR: 0.8)

D5200 2P GOLD or PdNi &Gold flash

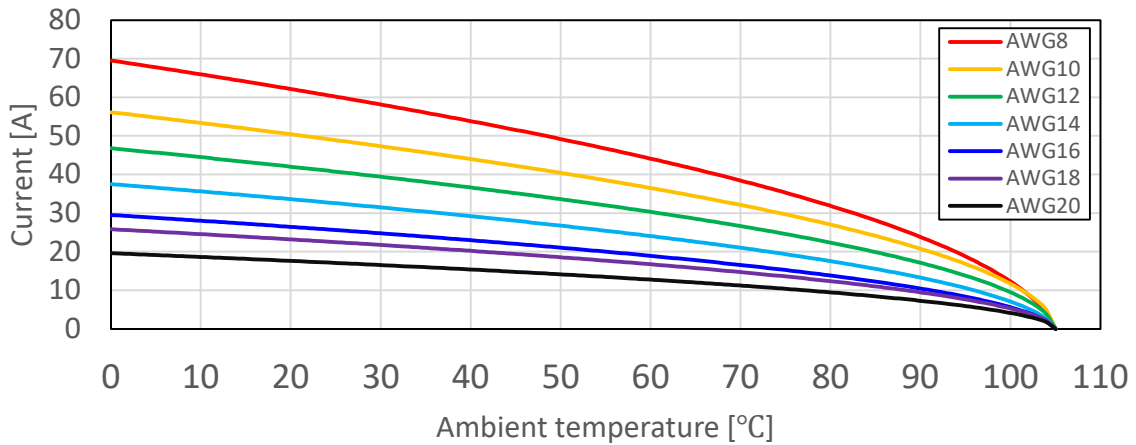

D5200 3P GOLD or PdNi &Gold flash

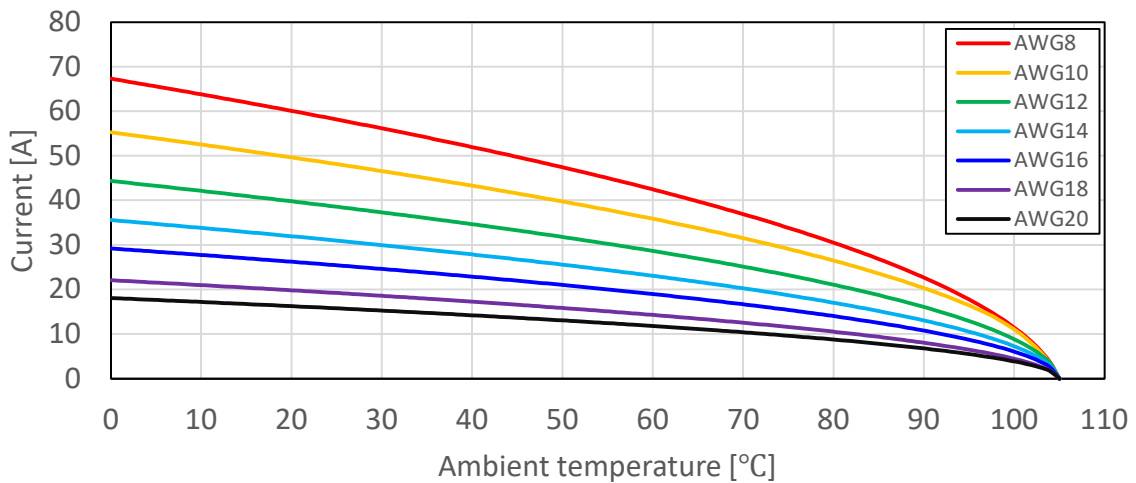

D5200 4P GOLD or PdNi &Gold flash

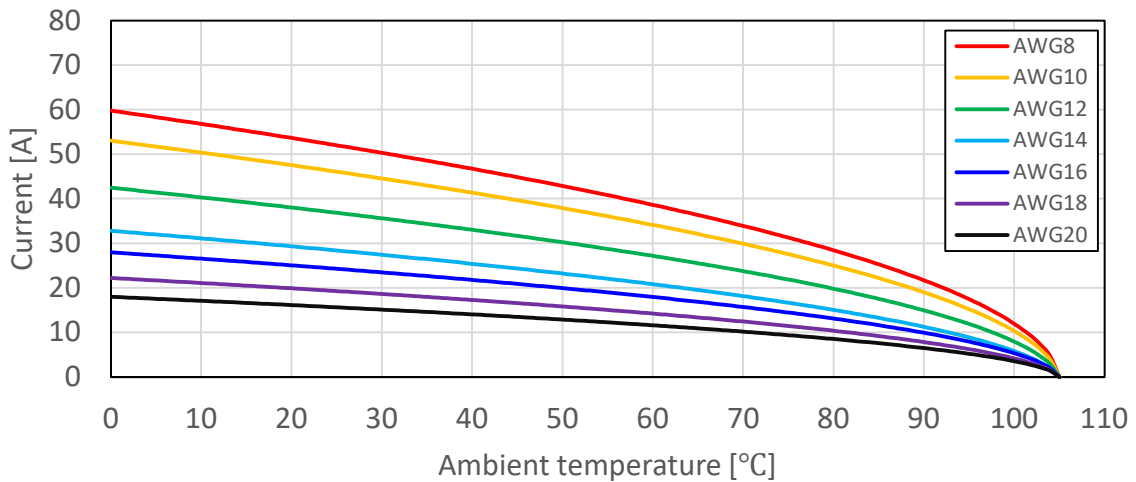

D5200 6P GOLD or PdNi & Gold flash

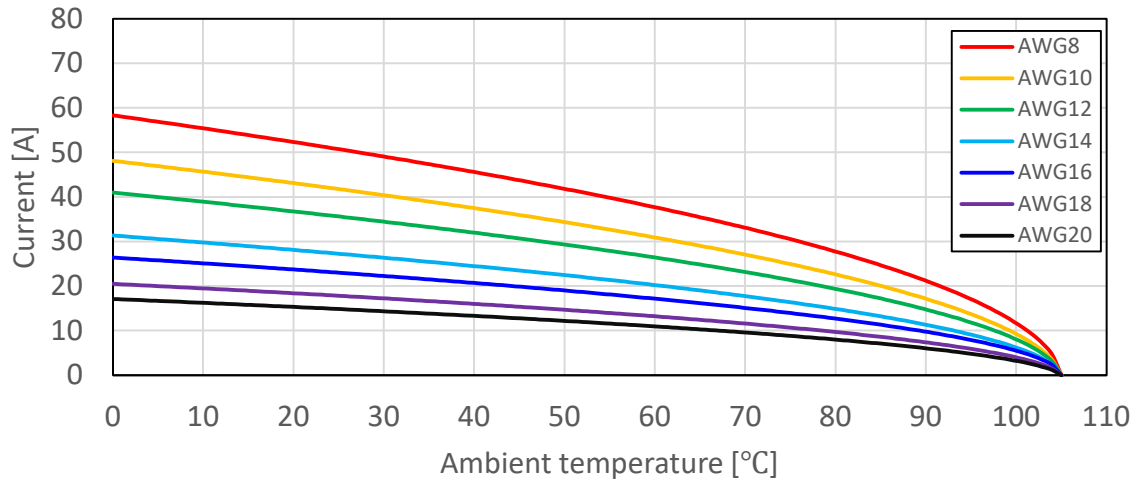

D5200 8P GOLD or PdNi & Gold flash

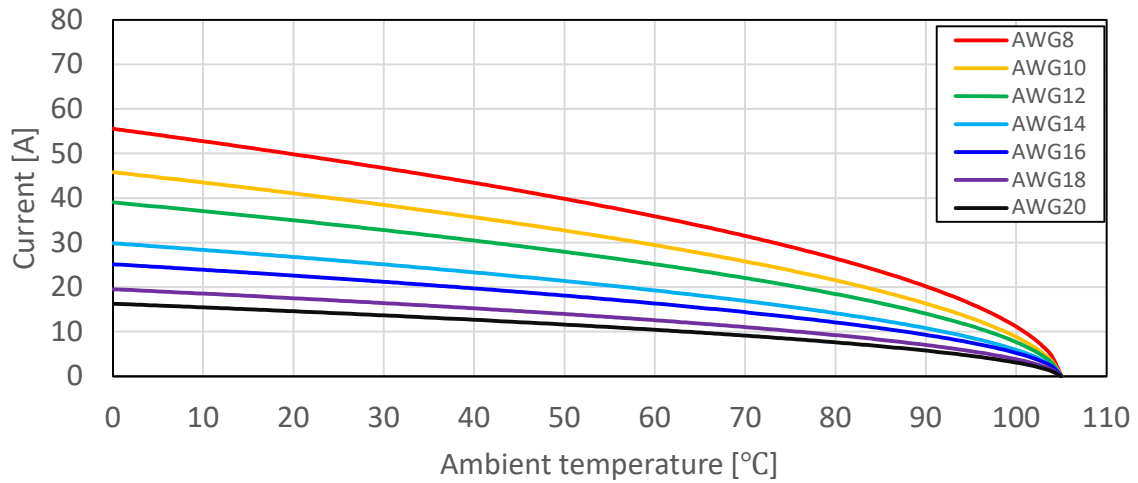

D5300 3P GOLD or PdNi & Gold flash

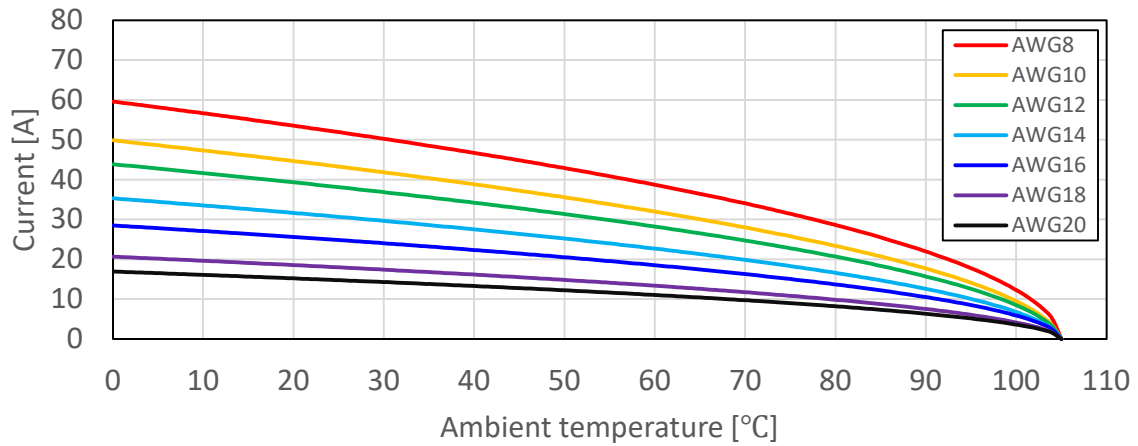

D5300 4P GOLD or PdNi &Gold flash

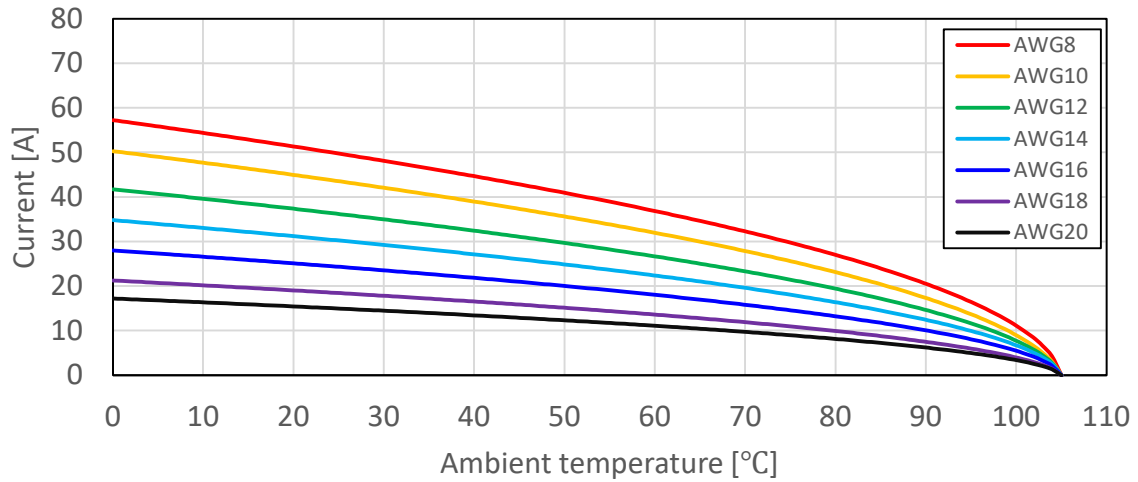

D5200alpha 4P GOLD or PdNi &Gold flash

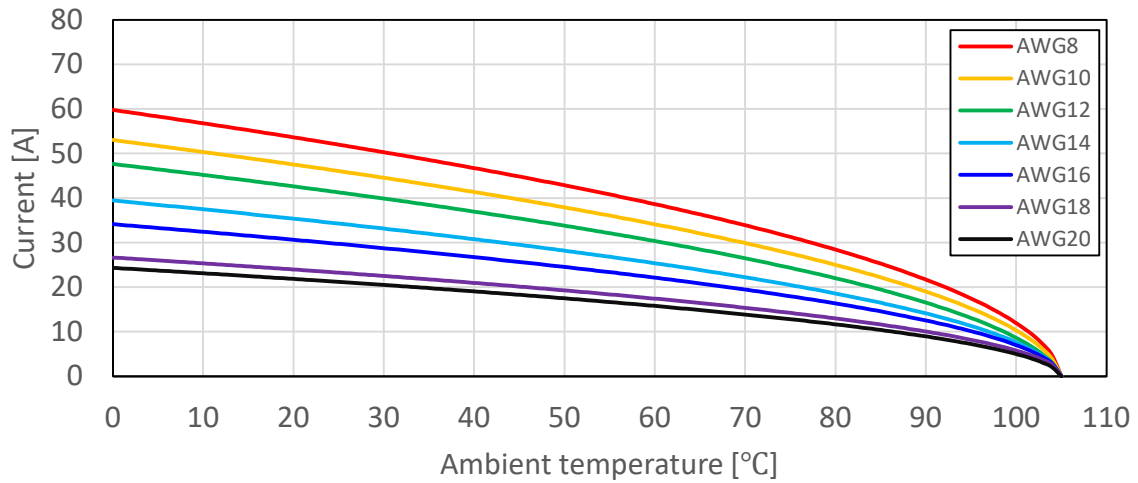

D5200 2P SILVER (WTW)

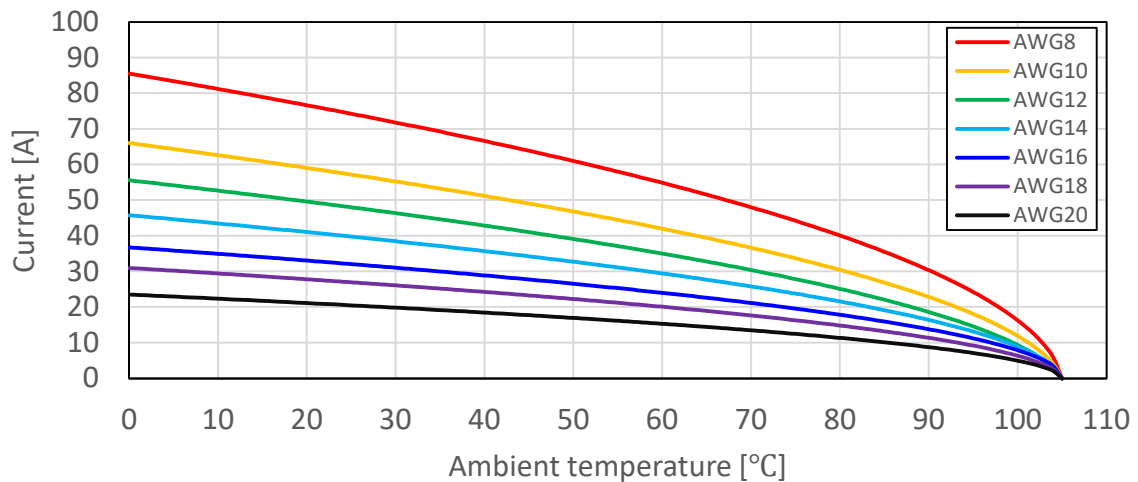

D5200 3P SILVER (WTW)

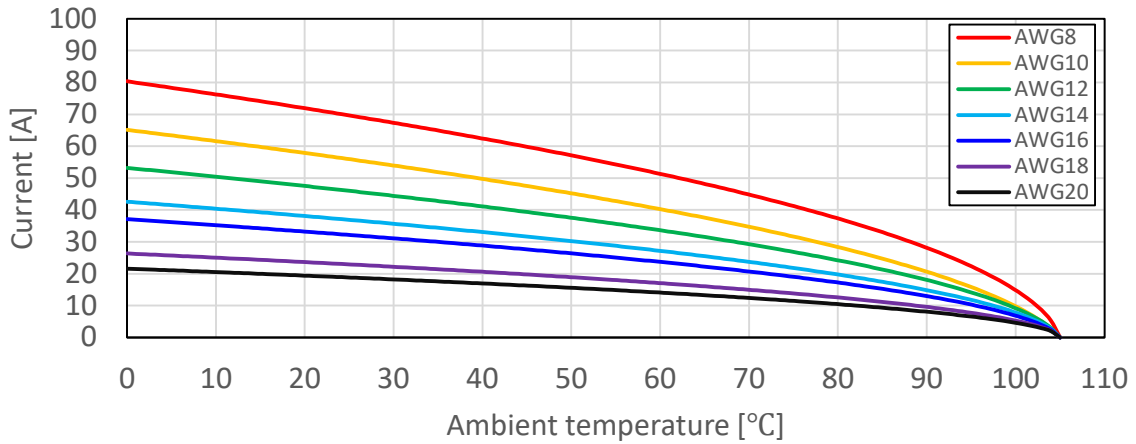

D5200 4P SILVER (WTW)

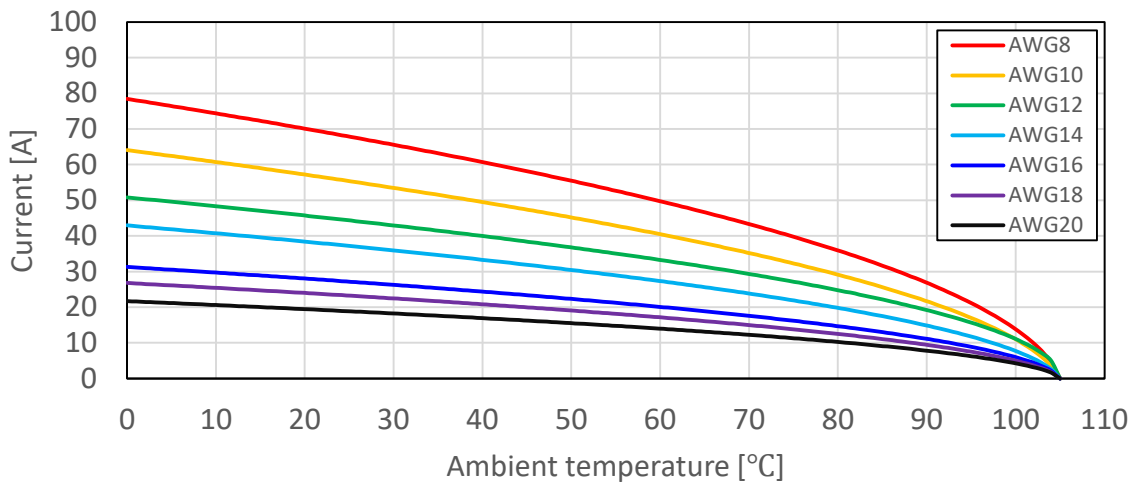

D5200 4P SILVER (WTB)

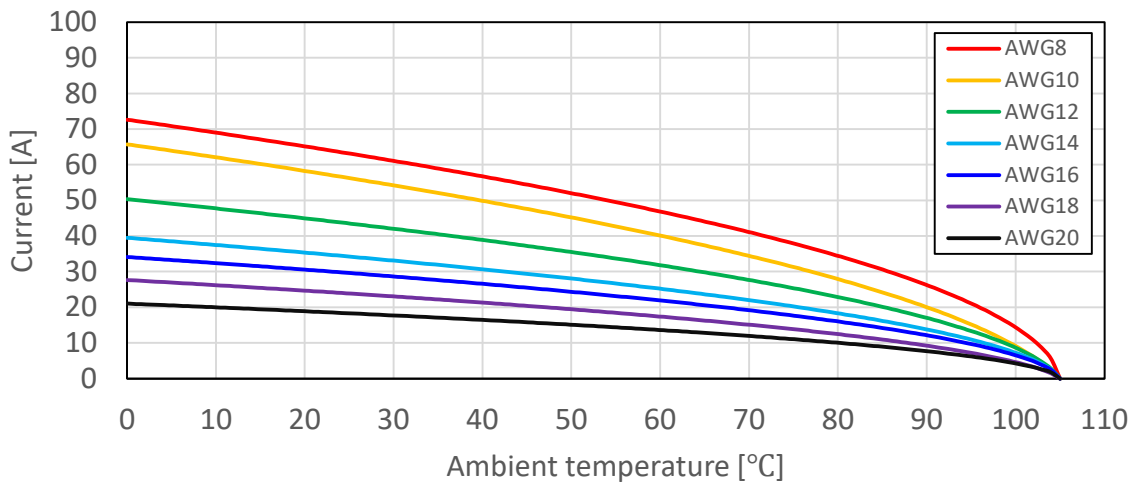

D5200 6P SILVER (WTW)

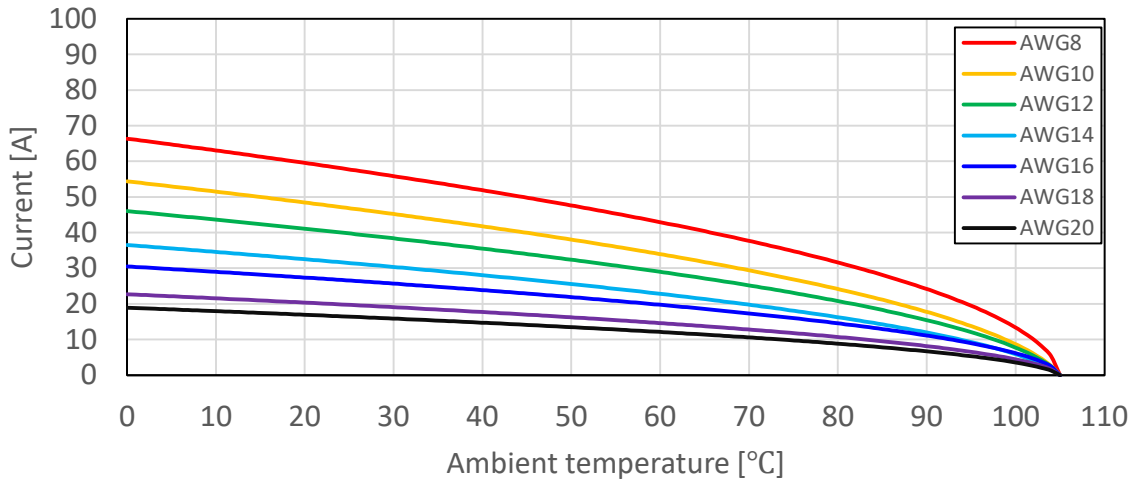

D5300 3P SILVER (WTW)

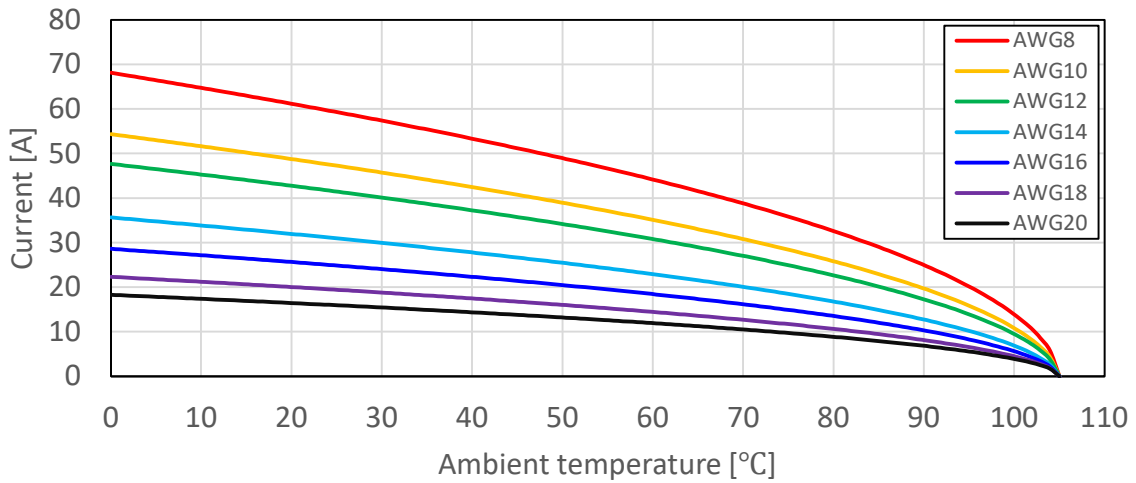

D5300 4P SILVER (WTW)

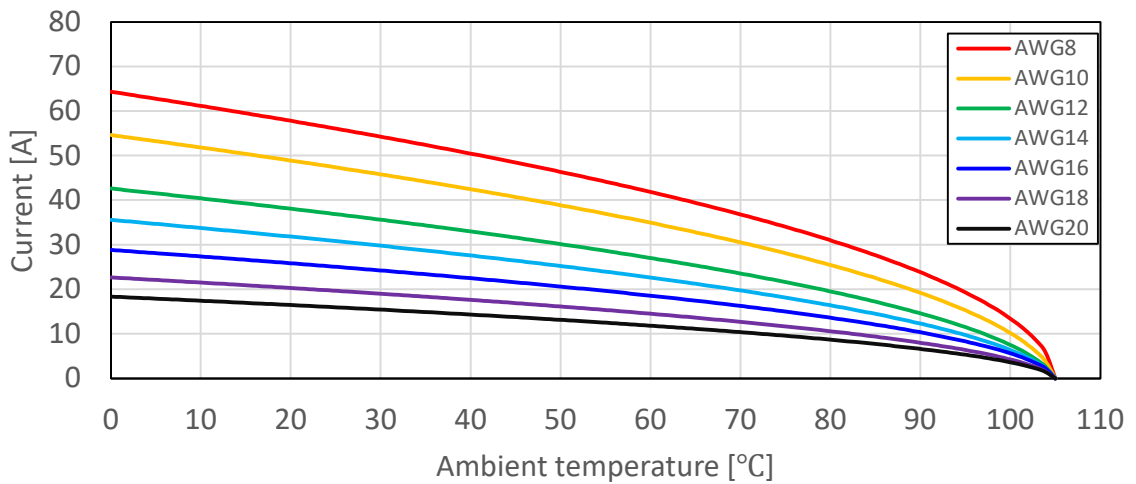

D5200alpha 4P SILVER (WTB)

