

This document is the property of Amphenol Corporation and is delivered on the express condition that is not to be disclosed, reproduced or used, in whole or in part, for manufacture or sale by anyone other than Amphenol Corporation without its prior consent, and that no right is granted to disclose or to use any information in this document.

The marking on this product doesn't contain environmental hazardous materials per Material Specification SS-00259 for Sony GP compliant or per directive 2011/65/EU for RoHS compliant.

FOR REFERENCE ONLY

REVISIONS				
SYM	ECN No.	DESCRIPTION	DATE	APPROVED
AX1	EDSR#5672	NON-RELEASE TO PRODUCTION	07/07/2015	Roger Tsai
AX2	EDSR#5984	ADD PACKAGE DRAWING	12/18/2015	Roger Tsai
AX3		ADD RECOMMENDED OPEN SIZES	03/23/2016	Roger Tsai

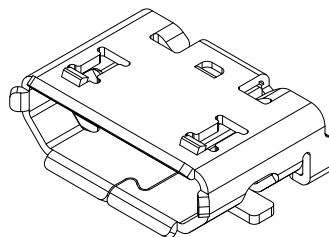
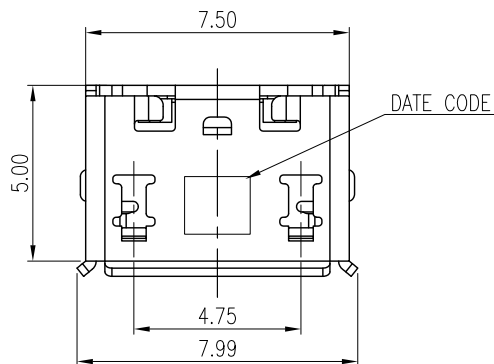

NOTES:

- MATERIAL:**
HOUSING: HIGH TEMPERATURE THERMAL PLASTIC LCP, UL94V-0, COLOR: BLACK.
TERMINAL: COPPER ALLOY.
SHELL: STAINLESS STEEL.
- FINISH:**
TERMINAL:
CONTACT AREA: SELECTIVE GOLD PLATING.;
SOLDERING AREA: GOLD FLASH PLATING.;
UNDER PLATING: NICKEL PLATING 50 μ" THICKNESS MIN. OVERALL.
SHELL:
MATTE TIN 100μ" PLATING.;
UNDER PLATING: NICKEL PLATING 50 μ" THICKNESS MIN. OVERALL.
- PACKING IS PER AMTA PACKING SPECIFICATION PKS-0001.
- THIS PRODUCT DOESN'T CONTAIN ENVIRONMENTAL HAZARDOUS PER DIRECTIVE 2011/65/EU FOR RoHS COMPLIANT.

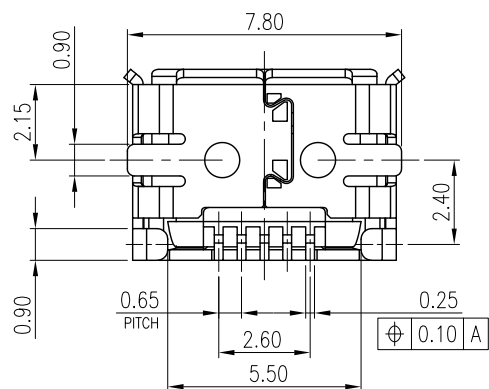
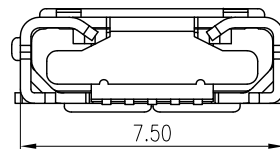
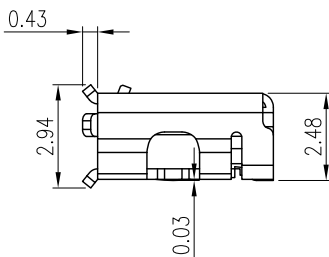
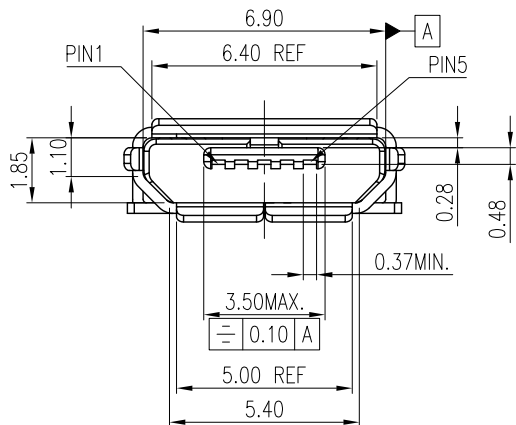

PART NUMBER:
GMCB 053 X 1 X 21BEU

CONTACT FINISH
0: GOLD FLASH
1: 15μ" GOLD
2: 30μ" GOLD

PACKAGING
1: TAPE&REEL

TOLERANCE	APPROVALS	DATE	TITLE		Amphenol®		
X. X.X ±0.30 X.XX ±0.20 X.XXX ±0.10	DRAWN Sandy Wu	03/23/2016	GMCB SERIES, MICRO USB B TYPE 5 POS. RECEPTACLE R/A, SMT		Amphenol Corporation Amphenol Taiwan Corporation		
ANGULAR ±1'	APPROVED Roger Tsai	03/23/2016		UNIT mm	SIZE A3	PART No. GMCB053X1X21BEU	
UNLESS OTHERWISE SPECIFIED	DWG TYPE CUST DWG	PROJECT CODE OTHER		SCALE NA	SHEET 1 OF 3	DWG No. GMCB053X1X21BEU	REV. AX3

This document is the property of Amphenol Corporation and is delivered on the express condition that is not to be disclosed, reproduced or used, in whole or in part, for manufacture or sale by anyone other than Amphenol Corporation without its prior consent, and that no right is granted to disclose or to use any information in this document.

The marking on this product doesn't contain environmental hazardous materials per Material Specification 55-00259 for Sony GP compliant or per directive 2011/65/EU for RoHS compliant.

REVISIONS				
SYM	ECN No.	DESCRIPTION	DATE	APPROVED
AX1	EDSR#5672	NON-RELEASE TO PRODUCTION	07/07/2015	Roger Tsai
AX2	EDSR#5984	ADD PACKAGE DRAWING	12/18/2015	Roger Tsai
AX3		ADD RECOMMENDED OPEN SIZES	03/23/2016	Roger Tsai

FOR REFERENCE ONLY

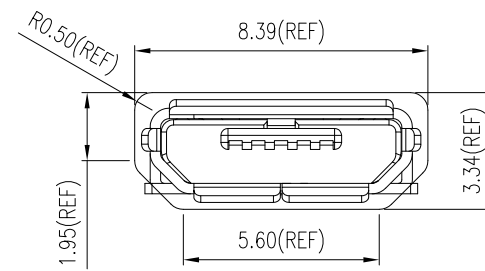
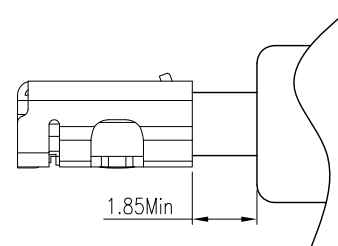
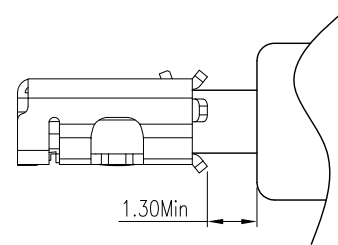
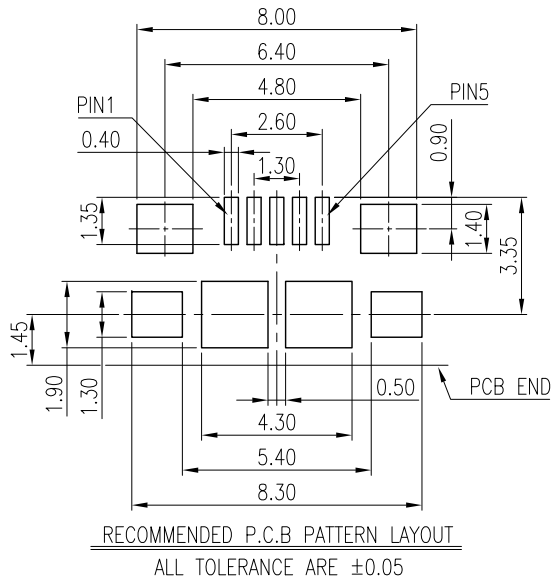

RECOMMENDED OPEN SIZES

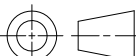
TOLERANCE		APPROVALS		DATE	TITLE		Amphenol®						
X.		DRAWN			GMCB SERIES, MICRO USB B TYPE 5 POS. RECEPTACLE R/A, SMT		Amphenol Corporation Amphenol Taiwan Corporation						
X.X	±0.30	Sandy Wu		03/23/2016									
X.XX	±0.20	CHECKED											
X.XXX	±0.10	Arron Lin		03/23/2016			UNIT	mm	SIZE	A3	PART No.	GMCB053X1X21BEU	
ANGULAR	±1°	APPROVED		Roger Tsai			03/23/2016	SCALE	NA	SHEET	2 OF 3	DWG No.	GMCB053X1X21BEU
UNLESS OTHERWISE SPECIFIED		DWG TYPE		PROJECT CODE									
		CUST DWG		OTHER									

This document is the property of Amphenol Corporation and is delivered on the express condition that is not to be disclosed, reproduced or used, in whole or in part, for manufacture or sale by anyone other than Amphenol Corporation without its prior consent, and that no right is granted to disclose or to use any information in this document.

The marking on this product doesn't contain environmental hazardous materials per Material Specification 55-00259 for Sony GP compliant or per directive 2011/65/EU for RoHS compliant.

REVISIONS				
SYM	ECN No.	DESCRIPTION	DATE	APPROVED
AX1	EDSR#5672	NON-RELEASE TO PRODUCTION	07/07/2015	Roger Tsai
AX2	EDSR#5984	ADD PACKAGE DRAWING	12/18/2015	Roger Tsai
AX3		ADD RECOMMENDED OPEN SIZES	03/23/2016	Roger Tsai

FOR REFERENCE ONLY

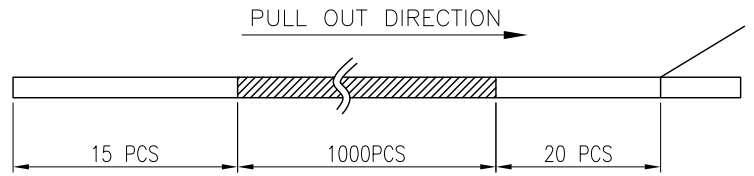
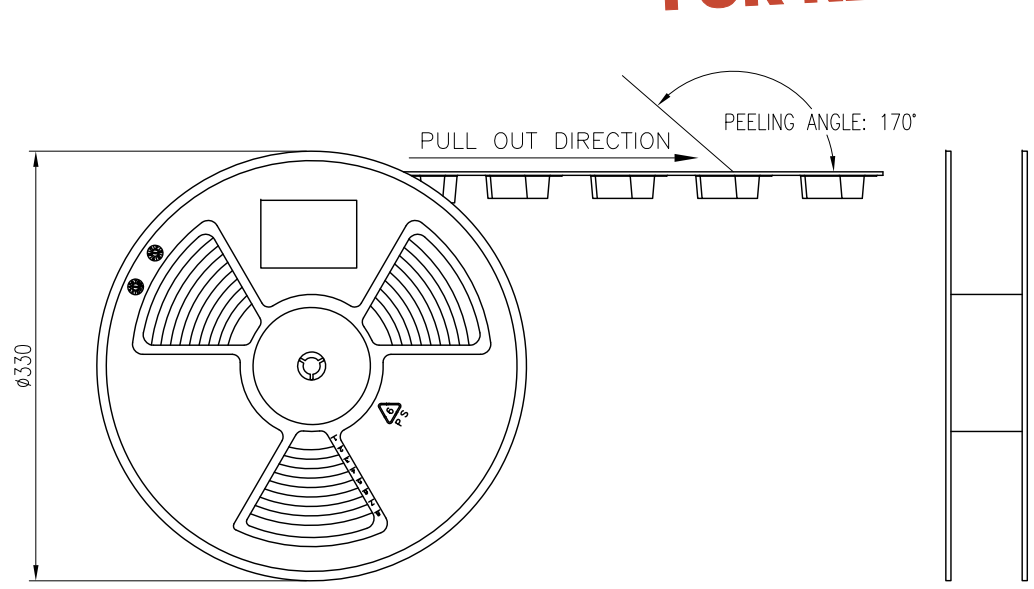

- NOTES:
1. 10 SPROCKET HOLE PITCH CUMULATIVE TOLERANCE ± 0.30 .
 2. MATERIAL: BLACK CONDUCTIVE POLYSTYRENE.
 3. THICKNESS: 0.50 ± 0.05 MM.
 4. COMPONENT LOAD PER 13" REEL.
 5. CARTON: 340*340*230 MM.

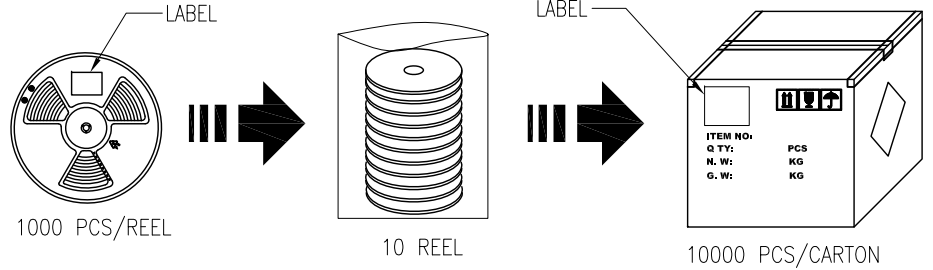
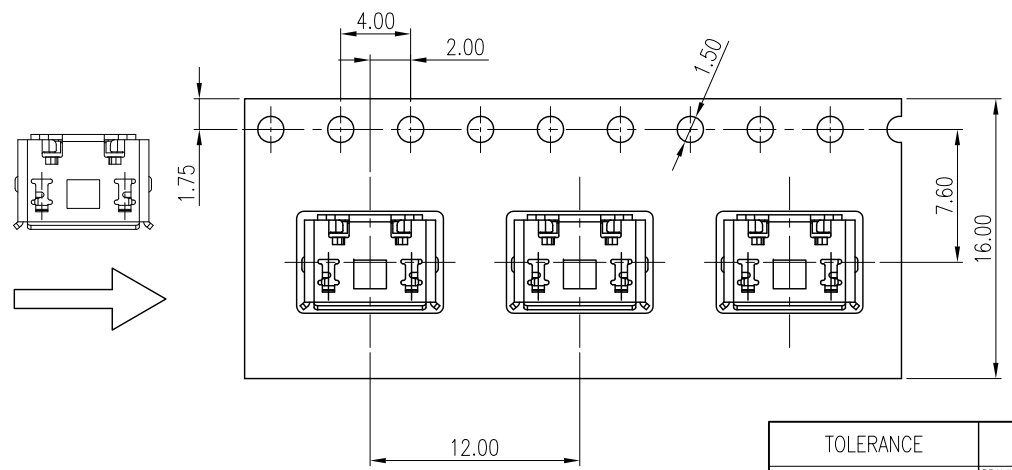

PACKAGING BY T&R	7.5	2.6	1000	10	10000	GMCB053X1X21BEU
	G/W KG	N/W KG	PCS/ REEL	REELS/ BOX	QUANTITY (PCS)	PART NUMBER

TOLERANCE	APPROVALS	DATE	TITLE		PART No.	
X. ± 0.30	DRAWN Sandy Wu	03/23/2016	GMCB SERIES, MICRO USB B TYPE 5 POS. RECEPTACLE R/A, SMT		Amphenol [®] Amphenol Corporation Amphenol Taiwan Corporation	
X.X ± 0.20	CHECKED Arron Lin	03/23/2016				
X.XXX ± 0.10	APPROVED Roger Tsai	03/23/2016			Part No. GMCB053X1X21BEU	
ANGULAR $\pm 1^\circ$	DWG TYPE CUST DWG	PROJECT CODE OTHER	UNIT mm	SIZE A3	DWG No. GMCB053X1X21BEU	
UNLESS OTHERWISE SPECIFIED			SCALE NA	SHEET 3 OF 3	REV. AX3	