

REVISIONS				
REV	DATE	DESCRIPTION	BY	APPV
AG1	18APR2025	ECR-25-239014	ABS	PS

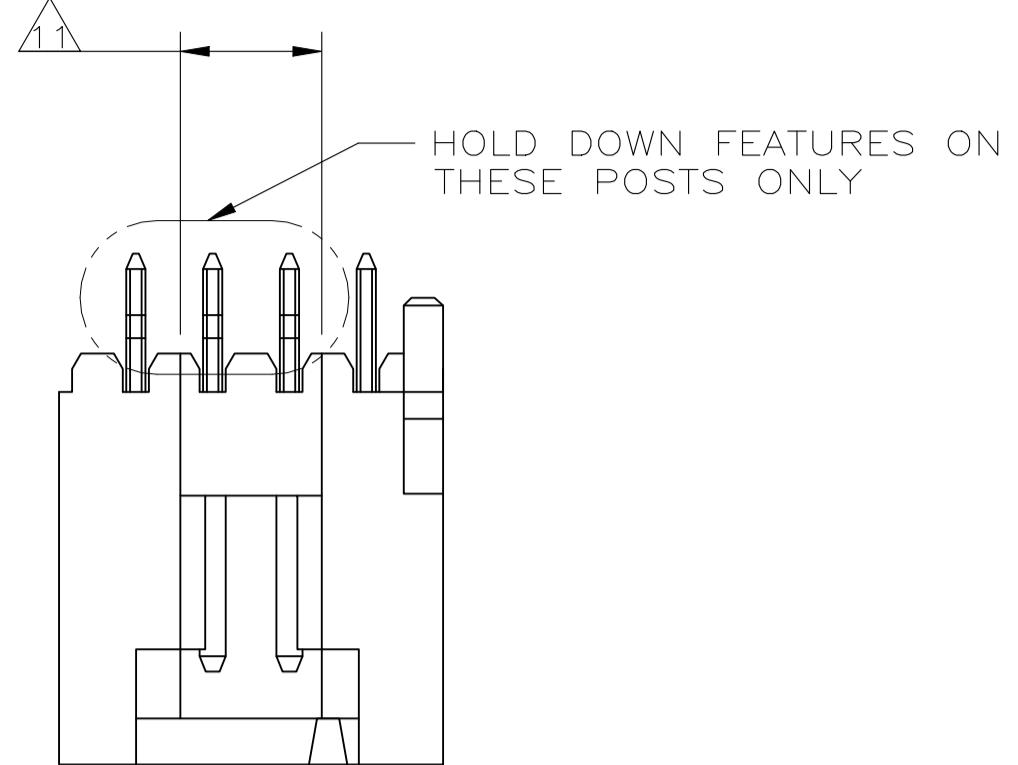

HOLD DOWN CONFIGURATION FOR 4 POSITION ASSEMBLY ONLY

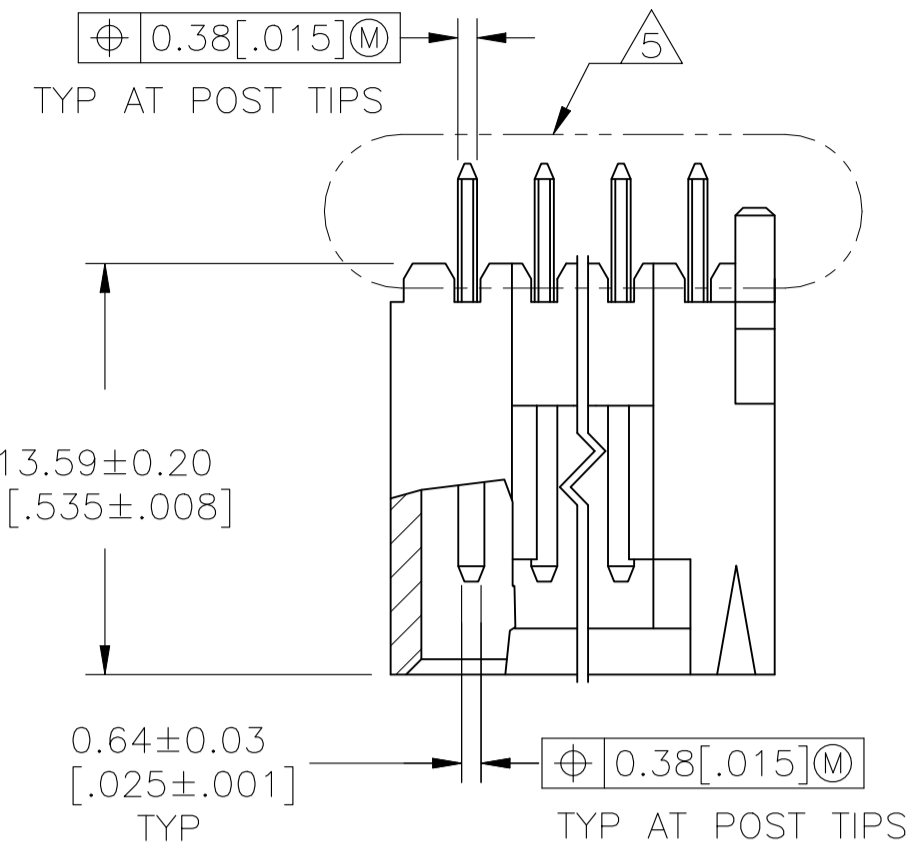
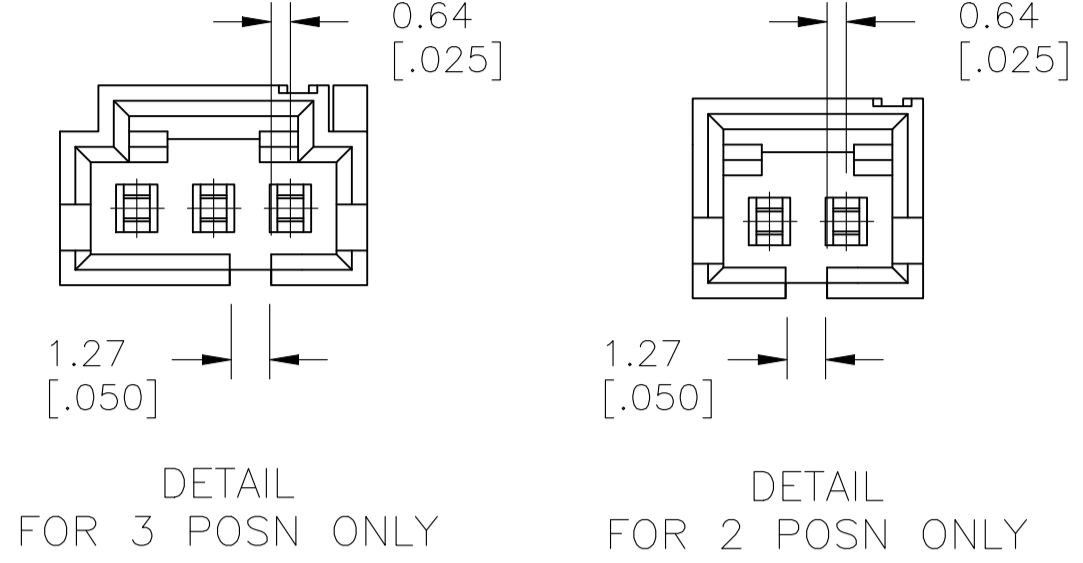

DETAIL FOR 3 POSN ONLY      DETAIL FOR 2 POSN ONLY

- 1 0.00254-0.00508 [.000100-.000200] BRIGHT TIN-LEAD OVER 0.00127 [.000050] NICKEL.
- 2 POINT OF MEASUREMENT FOR PLATING THICKNESS.
- 3 THESE DIMENSIONS APPLY WHERE THE POST INTERSECTS THE HOUSING.
- 4 ON ASSEMBLIES WITH FOUR OR MORE POSITIONS, TWO POLARIZATION SLOTS.
- 5 SELECT POST TAILS FORMED TO PROVIDE CONNECTOR HOLD DOWN UNTIL SOLDERED.CONFIGURATION ACCEPTS 0.69-2.03 [.027-.080] THICK PRINTED CIRCUIT BOARD. (SEE DETAIL Z).
- 6 MATERIAL: HOUSING- LCP, COLOR-BLACK. POSTS- BRASS.
- 7 0.00254-0.00508 [.000100-.000200] BRIGHT TIN OVER 0.00127 [.000050] NICKEL.
- 8 HIGH TEMPERATURE CONFIGURATION.
- 9 0.00254-0.00508 [.000100-.000200] MATTE TIN OVER 0.00127 [.000050] NICKEL.
- 10 OBSOLETE PARTS: OBSOLETE CIS STREAMLINING PER D.RENAUD/D.SINISI.
- 11 0.25 [.010] RECESS PERMISSIBLE IN THIS AREA FOR MOLD SHUT OFF

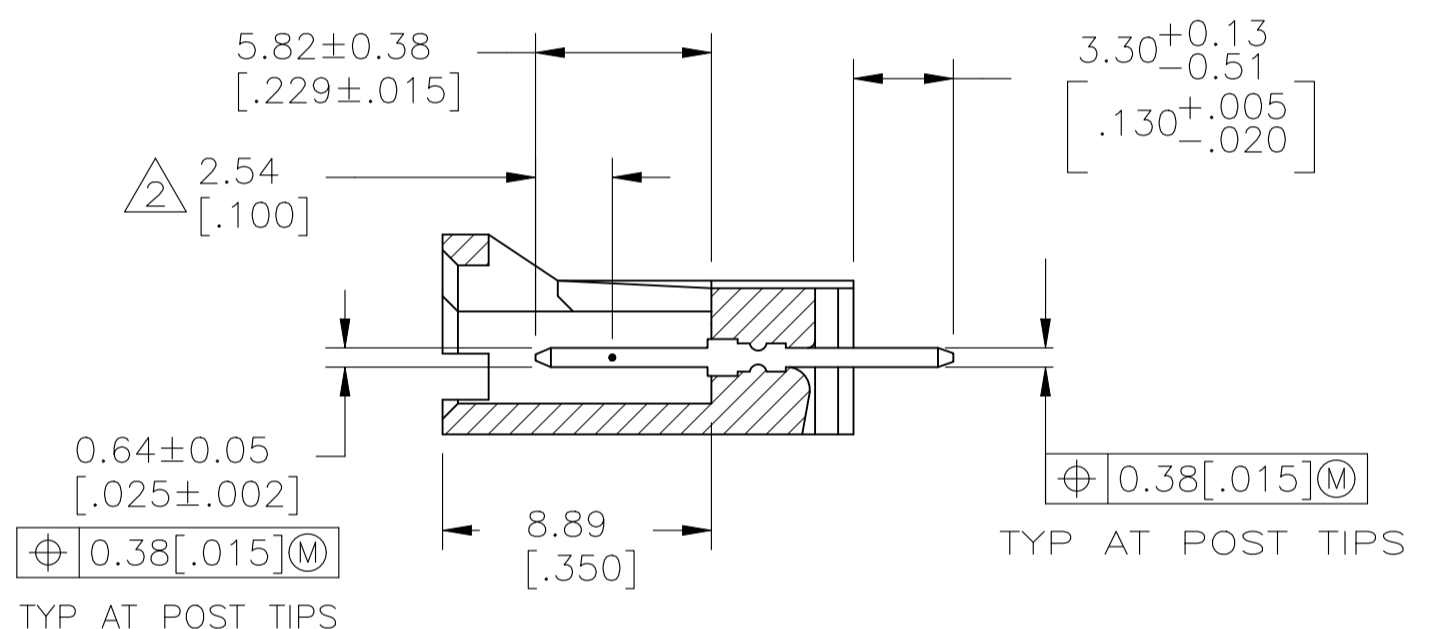
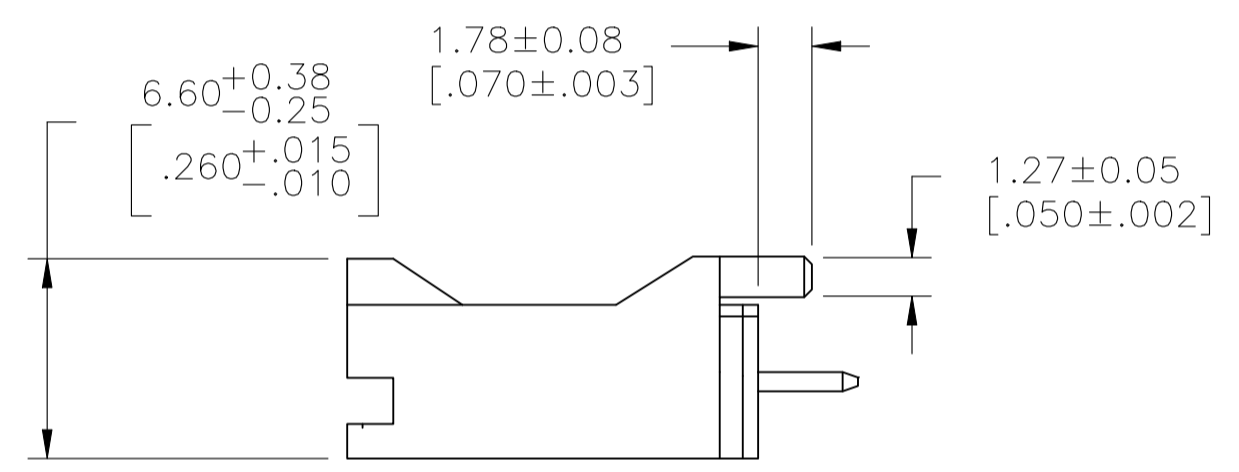
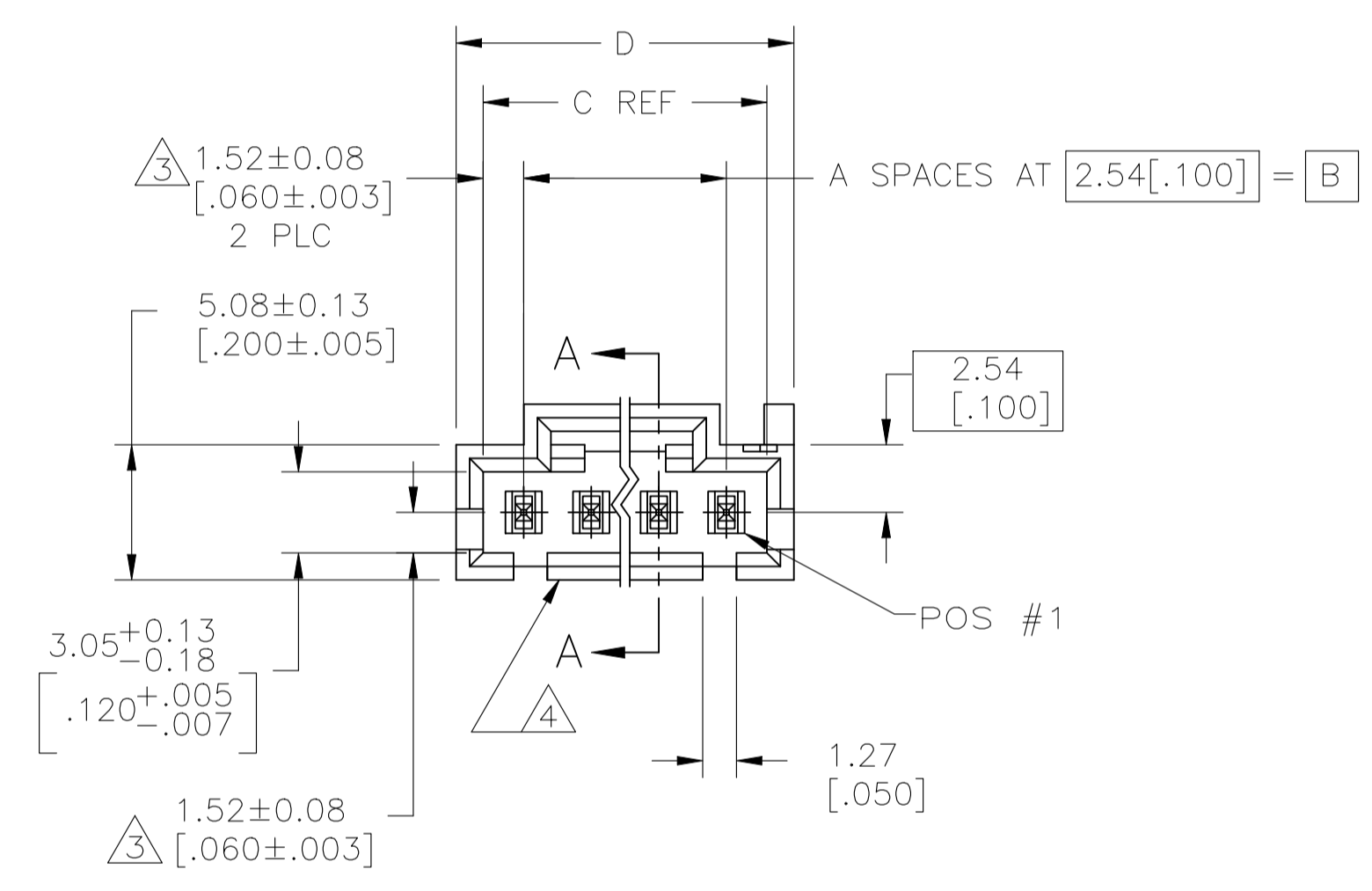

SECTION A-A

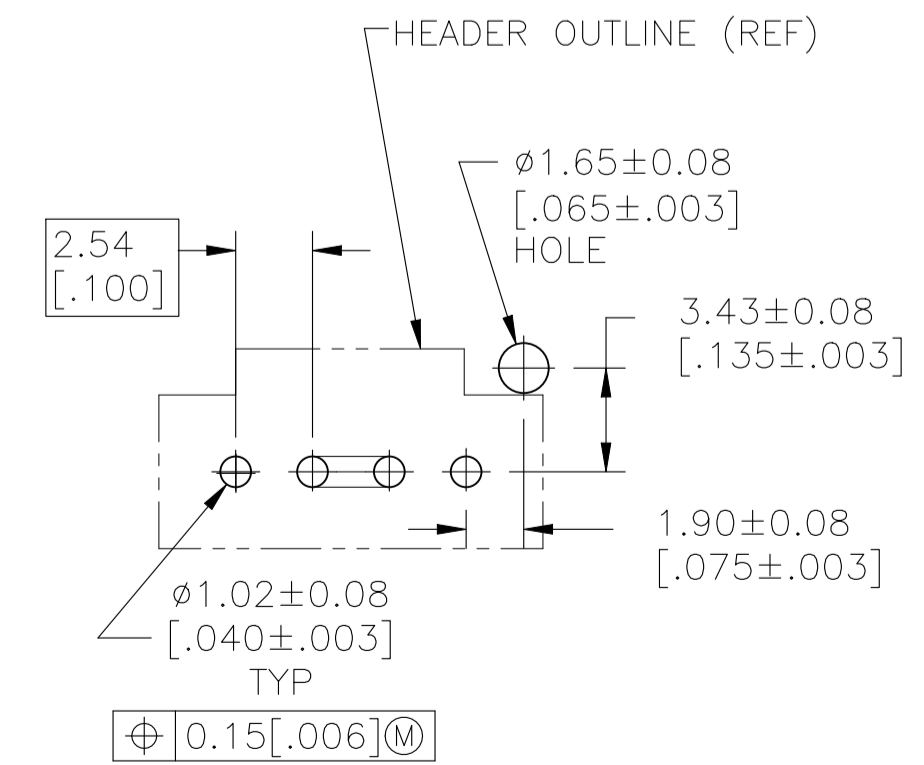

RECOMMENDED HOLE LAYOUT

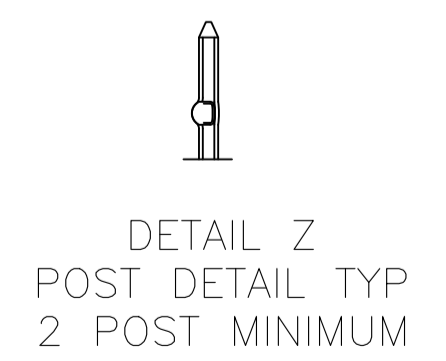

REMARKS	PLATING	D	C	B	A	NO OF POSN	ASSEMBLY PART NUMBER
10 OBSOLETE		27.81 [1.095]	25.91 [1.020]	22.86 [.900]	9	10	5-104450-9
		25.27 [.995]	23.37 [.920]	20.32 [.800]	8	9	5-104450-8
10 OBSOLETE		22.73 [.895]	20.83 [.820]	17.78 [.700]	7	8	5-104450-7
		20.19 [.795]	18.29 [.720]	15.24 [.600]	6	7	5-104450-6
		17.65 [.695]	15.75 [.620]	12.7 [.500]	5	6	5-104450-5
		15.11 [.595]	13.21 [.520]	10.16 [.400]	4	5	5-104450-4
		12.57 [.495]	10.67 [.420]	7.62 [.300]	3	4	5-104450-3
		10.03 [.395]	8.13 [.320]	5.08 [.200]	2	3	5-104450-2
		7.49 [.295]	5.59 [.220]	2.54 [.100]	1	2	5-104450-1
10 OBSOLETE		20.19 [.795]	18.29 [.720]	15.24 [.600]	6	7	1-104450-3
OBSOLETE		15.11 [.595]	13.21 [.520]	10.16 [.400]	4	5	1-104450-2
		10.03 [.395]	8.13 [.320]	5.08 [.200]	2	3	1-104450-1
		12.57 [.495]	10.67 [.420]	7.62 [.300]	3	4	1-104450-0
		27.81 [1.095]	25.91 [1.020]	22.86 [.900]	9	10	104450-9
10 OBSOLETE		25.27 [.995]	23.37 [.920]	20.32 [.800]	8	9	104450-8
SUPERSEDED BY 5-104450-7		22.73 [.895]	20.83 [.820]	17.78 [.700]	7	8	104450-7
OBSOLETE		20.19 [.795]	18.29 [.720]	15.24 [.600]	6	7	104450-6
SUPERSEDED BY 5-104450-5		17.65 [.695]	15.75 [.620]	12.7 [.500]	5	6	104450-5
SUPERSEDED BY 5-104450-4		15.11 [.595]	13.21 [.520]	10.16 [.400]	4	5	104450-4
		12.57 [.495]	10.67 [.420]	7.62 [.300]	3	4	104450-3
SUPERSEDED BY 5-104450-2		10.03 [.395]	8.13 [.320]	5.08 [.200]	2	3	104450-2
		7.49 [.295]	5.59 [.220]	2.54 [.100]	1	2	104450-1

THIS DRAWING IS A CONTROLLED DOCUMENT.

DIMENSIONS: mm	TOLERANCES UNLESS OTHERWISE SPECIFIED:	DIN R BROWN 09FEB01	APPROV K WRIGHT 09FEB01	NAME
0 PLC ± -	1 PLC ± -	2 PLC ± -	3 PLC ± 0.38 [.005]	4 PLC ± -
ANGLES ± -				
MATERIAL SEE NOTE 6	FINISH SEE TABLE	WEIGHT -	SIZE A1	CAGE CODE 00779
			DRAWING NO 104450	RESTRICTED TO
		CUSTOMER DRAWING	SCALE 4:1	SHEET 1 OF 1

STE TE Connectivity

HEADER ASSY, AMPMODU MTE, VERTICAL, WITH LATCH, SINGLE ROW, .100 CL, .025 SQ POSTS, PCB ORIENTATION, AND RETENTIVE POSTS

108-25034