

REVISIONS					
P	LTR	DESCRIPTION	DATE	DWN	APVD
M3		ECR-25-266356	06JAN2026	ABS	PS

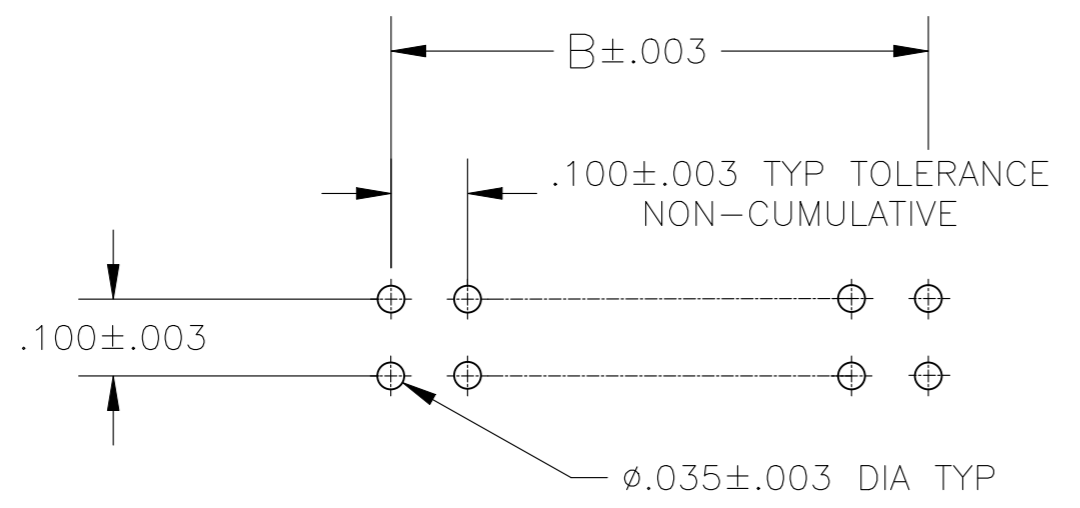
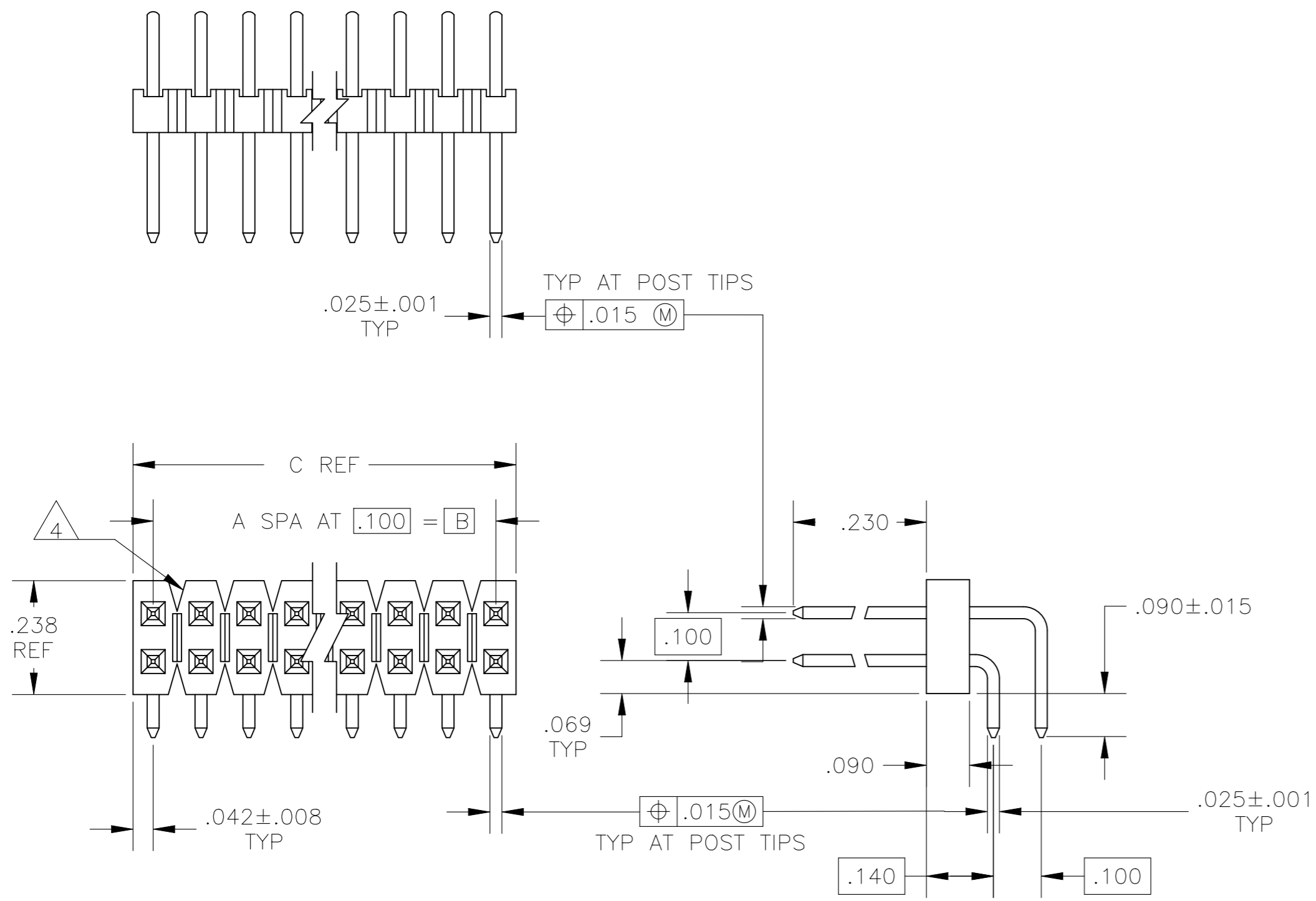

RECOMMENDED HOLE LAYOUT

- 1 ASSEMBLIES MAY BE BROKEN TO THE DESIRED NUMBER OF POSITIONS
- 2 TRUE POSITION TOLERANCE OF THE POST TIPS APPLIES WHEN THE HEADERS ARE HELD FLAT AGAINST THE PRINTED CIRCUIT BOARD
- 3 .000100-.000200 MATTE TIN-LEAD OVER .000050 NICKEL ENTIRE POST
- 4 BREAKAWAY NOTCH ANGLE CAN BE ORIENTED TO THE RIGHT (AS SHOWN) OR TO THE LEFT
- 5 .000100-.000200 BRIGHT TIN OVER .000050 NICKEL ENTIRE POST
- 6 .000100-.000200 MATTE TIN OVER .000050 NICKEL ENTIRE POST
- 7 HIGH TEMP CONFIGURATION
- 8 OBSOLETE PARTS: OBSOLETE CIS STREAMLINING PER D.RENAUD/D.SINISI

THIS DRAWING IS A CONTROLLED DOCUMENT.		DWN L. D. RINGLEY 30JUL85	TE Connectivity Ltd.	
DIMENSIONS: INCHES		CHK J. GESFORD 27AUG03		
TOLERANCES UNLESS OTHERWISE SPECIFIED:		APVD J. GESFORD 27AUG03	NAME	
0 PLC ± - 1 PLC ± - 2 PLC ± - 3 PLC ± .005 4 PLC ± - ANGLES ± -		PRODUCT SPEC	ASSEMBLY, MOD II, HEADER, BREAKAWAY, DOUBLE ROW, RIGHT ANGLE, .100X.100 C/L, WITH .025 SQ. POSTS	
MATERIAL CONTACT: COPPER ALLOY		FINISH SEE TABLE	WEIGHT -	RESTRICTED TO
		CUSTOMER DRAWING	SCALE 4:1	SHEET 1 OF 2
			SIZE A2	REV M3
			CAGE CODE 00779	DRAWING NO C=103795

REVISIONS

P	LTR	DESCRIPTION	DATE	DWN	APVD
-	-	SEE SHEET 1	-	-	-

REMARKS	PLATING	C	B	A	NO OF POS	ASSEMBLY PART NUMBER
7	6	3.984	3.900	39	80	9-103795-0
7	6	3.884	3.800	38	78	8-103795-9
7	6	3.784	3.700	37	76	8-103795-8
7	6	3.684	3.600	36	74	8-103795-7
7	6	3.584	3.500	35	72	8-103795-6
7	6	3.484	3.400	34	70	8-103795-5
7	6	3.284	3.300	33	68	8-103795-4
7	6	3.284	3.200	32	66	8-103795-3
7	6	3.184	3.100	31	64	8-103795-2
7	6	3.084	3.000	30	62	8-103795-1
7	6	2.984	2.900	29	60	8-103795-0
7	6	2.884	2.800	28	58	7-103795-9
7	6	2.784	2.700	27	56	7-103795-8
7	6	2.684	2.600	26	54	7-103795-7
7	6	2.584	2.500	25	52	7-103795-6
7	6	2.484	2.400	24	50	7-103795-5
7	6	2.384	2.300	23	48	7-103795-4
7	6	2.284	2.200	22	46	7-103795-3
7	6	2.184	2.100	21	44	7-103795-2
7	6	2.084	2.000	20	42	7-103795-1
7	6	1.984	1.900	19	40	7-103795-0
7	6	1.884	1.800	18	38	6-103795-9
7	6	1.784	1.700	17	36	6-103795-8
7	6	1.684	1.600	16	34	6-103795-7
7	6	1.584	1.500	15	32	6-103795-6
7	6	1.484	1.400	14	30	6-103795-5
7	6	1.384	1.300	13	28	6-103795-4
7	6	1.284	1.200	12	26	6-103795-3
7	6	1.184	1.100	11	24	6-103795-2
7	6	1.084	1.000	10	22	6-103795-1
7	6	.984	.900	9	20	6-103795-0
7	6	.884	.800	8	18	5-103795-9
7	6	.784	.700	7	16	5-103795-8
7	6	.684	.600	6	14	5-103795-7
7	6	.584	.500	5	12	5-103795-6
7	6	.484	.400	4	10	5-103795-5
7	6	.384	.300	3	8	5-103795-4
7	6	.284	.200	2	6	5-103795-3
7	6	.184	.100	1	4	5-103795-2
7	6	.084	---	---	2	5-103795-1

OBSOLETE

OBSOLETE

REMARKS	PLATING	C	B	A	NO OF POS	ASSEMBLY PART NUMBER
5	3	.384	.300	3	8	4-103795-1
3	3	3.984	3.900	39	80	4-103795-0
3	3	3.884	3.800	38	78	3-103795-9
3	3	3.784	3.700	37	76	3-103795-8
3	3	3.684	3.600	36	74	3-103795-7
3	3	3.584	3.500	35	72	3-103795-6
3	3	3.484	3.400	34	70	3-103795-5
3	3	3.284	3.300	33	68	3-103795-4
3	3	3.284	3.200	32	66	3-103795-3
3	3	3.184	3.100	31	64	3-103795-2
3	3	3.084	3.000	30	62	3-103795-1
3	3	2.984	2.900	29	60	3-103795-0
3	3	2.884	2.800	28	58	2-103795-9
3	3	2.784	2.700	27	56	2-103795-8
3	3	2.684	2.600	26	54	2-103795-7
3	3	2.584	2.500	25	52	2-103795-6
3	3	2.484	2.400	24	50	2-103795-5
3	3	2.384	2.300	23	48	2-103795-4
3	3	2.284	2.200	22	46	2-103795-3
3	3	2.184	2.100	21	44	2-103795-2
3	3	2.084	2.000	20	42	2-103795-1
3	3	1.984	1.900	19	40	2-103795-0
3	3	1.884	1.800	18	38	1-103795-9
3	3	1.784	1.700	17	36	1-103795-8
3	3	1.684	1.600	16	34	1-103795-7
3	3	1.584	1.500	15	32	1-103795-6
3	3	1.484	1.400	14	30	1-103795-5
3	3	1.384	1.300	13	28	1-103795-4
3	3	1.284	1.200	12	26	1-103795-3
3	3	1.184	1.100	11	24	1-103795-2
3	3	1.084	1.000	10	22	1-103795-1
3	3	.984	.900	9	20	1-103795-0
3	3	.884	.800	8	18	103795-9
3	3	.784	.700	7	16	103795-8
3	3	.684	.600	6	14	103795-7
3	3	.584	.500	5	12	103795-6
3	3	.484	.400	4	10	103795-5
3	3	.384	.300	3	8	103795-4
3	3	.284	.200	2	6	103795-3
3	3	.184	.100	1	4	103795-2
3	3	.084	---	---	2	103795-1

OBSOLETE

OBSOLETE

OBSOLETE

OBSOLETE

OBSOLETE

OBSOLETE

THIS DRAWING IS A CONTROLLED DOCUMENT.

DWN L. D. RINGLEY 30JUL85	CHK J. GESFORD 27AUG03	APVD J. GESFORD 27AUG03	NAME
TE Connectivity Ltd.			ASSEMBLY, MOD II, HEADER, BREAKAWAY, DOUBLE ROW, RIGHT ANGLE, .100X.100 C/L, WITH .025 SQ. POSTS
DIMENSIONS: INCHES		TOLERANCES UNLESS OTHERWISE SPECIFIED: 0 PLC ± - 1 PLC ± - 2 PLC ± - 3 PLC ± .005 4 PLC ± - ANGLES ± -	SIZE A2
MATERIAL -		FINISH SEE TABLE	CAGE CODE 00779
WEIGHT -		APPLICATION SPEC -	DRAWING NO C=103795
CUSTOMER DRAWING		SCALE 1:1	RESTRICTED TO -
		SHEET 2 OF 2	REV M3