

THIS DRAWING IS UNPUBLISHED. RELEASED FOR PUBLICATION 20  
 © COPYRIGHT 20 ALL RIGHTS RESERVED.

LOC	DIST	REVISIONS			
P	LTR	DESCRIPTION	DATE	DWN	APVD
		C2	REVISED PER ECO-11-021326	04NOV2011	KH MS
		C3	NEW TCPN 3-282808-3 ADDED	02JUN2025	NMP PS

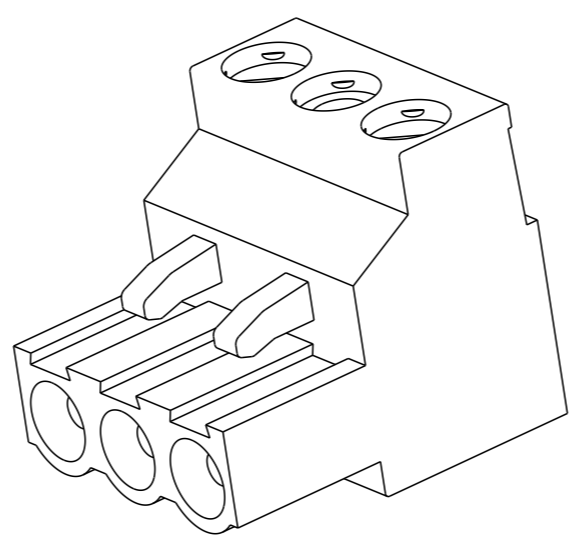

- NOTES:
- 1 MATERIALS AND FINISH  
 HOUSING: PA 6-6, UL 94-V0, COLOR GREEN.  
 CLAMP: BRASS, NICKEL PLATED.  
 DOUBLE SIDE CONTACT SPRING: PHOSPHOR BRONZE, TIN PLATED.  
 CLAMPING SCREW: M3, BRASS, NICKEL PLATED.
  - 2 WIRE SIZE RANGE  
 SOLID WIRE: 0,03-2,5mm (13AWG).  
 STRANDED WIRE: 0,03-1,5mm (15AWG).
  - 3 RECOGNIZED UNDER THE COMPONENT PROGRAM OF UNDERWRITERS LABORATORIES INC., FILE° E60677.
  - 4 IMQ CERTIFICATE WITH SURVEILLANCE IN CONFORMITY WITH IEC 998-1/998-2-1.
  - 5 NOT CUMULATIVE TOLERANCE.
  - 6 PERMANENT MARKING, COLOR BLACK.
  - 7 PART WITH ORANGE COLOR HOUSING

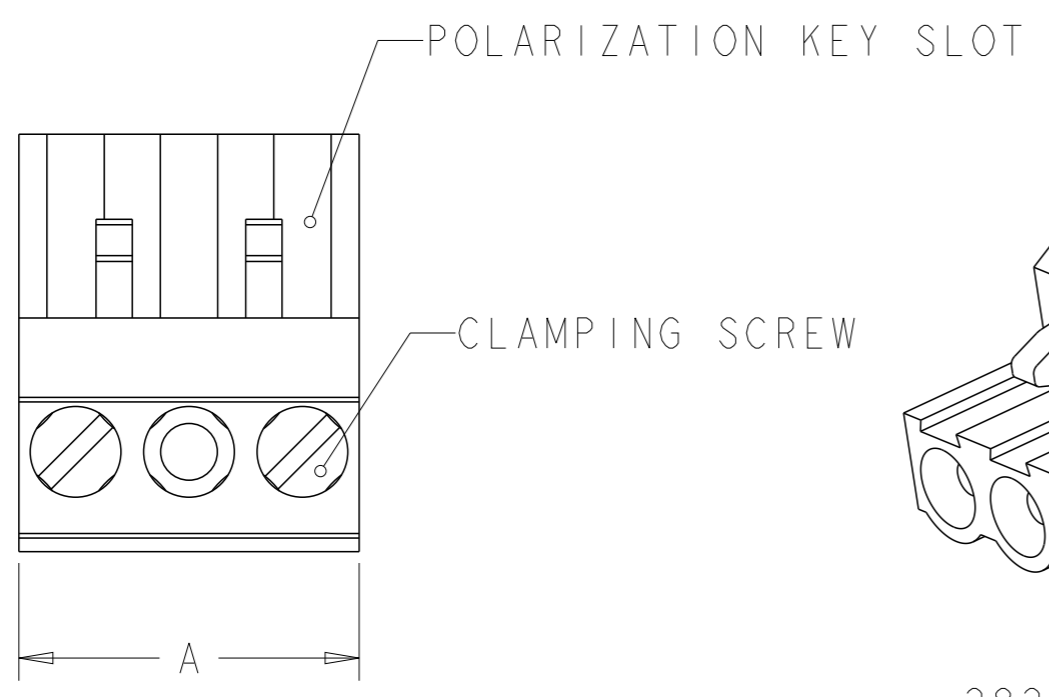
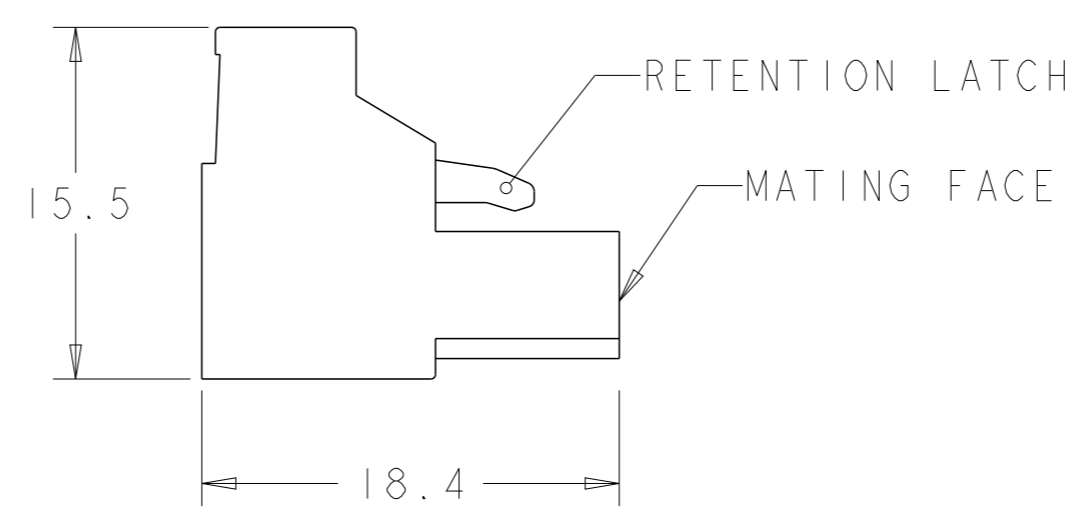
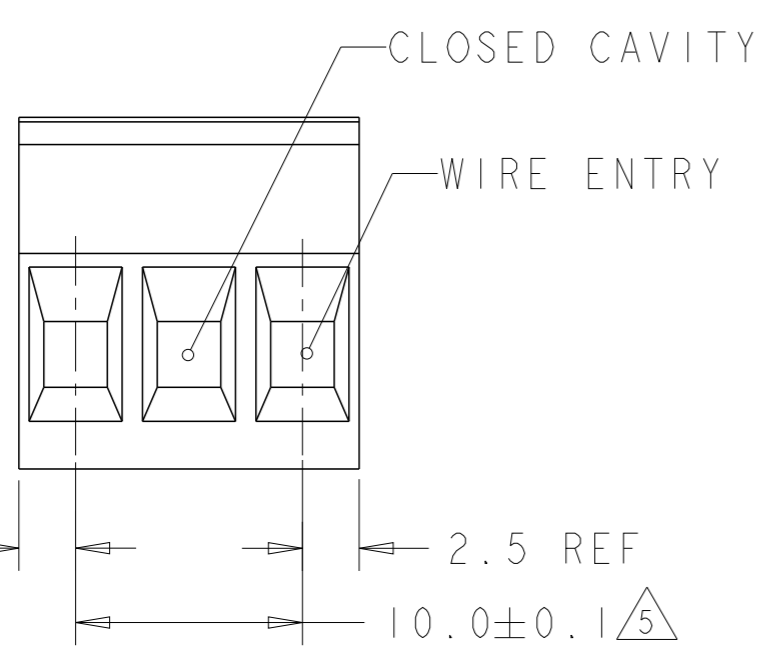

7	25	3	3-282808-3
6	35	4	1-282808-4
	125	13	1-282808-3
	115	12	1-282808-2
	105	11	1-282808-1
	95	10	1-282808-0
	85	9	282808-9
	75	8	282808-8
	65	7	282808-7
	55	6	282808-6
	45	5	282808-5
	35	4	282808-4
	25	3	282808-3
	15	2	282808-2
	<b>DIM. A</b>	<b>NO OF POS.</b>	<b>PART NUMBER</b>

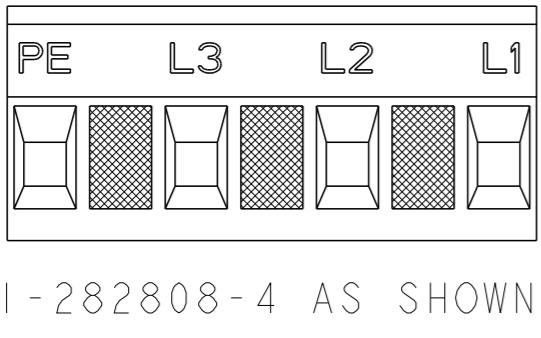

THIS DRAWING IS A CONTROLLED DOCUMENT.

DIMENSIONS: mm	TOLERANCES UNLESS OTHERWISE SPECIFIED: 0 PLC ± 1 PLC ±0.2 2 PLC ±0.25 3 PLC ± 4 PLC ± ANGLES ±2	DWN E. ZANOLINI 23JUL2001 CHK D. BIEVENOUR 23JUL2001 APVD D. BIEVENOUR 23JUL2001	TE Connectivity <b>TERMINAL BLOCK PLUG</b> 10mm PITCH
MATERIAL	FINISH	PRODUCT SPEC 108-161088 APPLICATION SPEC 114-20079 WEIGHT -	
CUSTOMER DRAWING		SIZE A3 CAGE CODE 00779 DRAWING NO C-282808	RESTRICTED TO
		SCALE 3:1 SHEET 1 OF 1	REV C3