

REVISIONS				
P	LTR	DESCRIPTION	DATE	APVD
	U3	REVISED PER ECR-25-255998	15SEP2025	SA DSC

AMP WIRE RANGE	Listed FILE E13288	LR7189 Certified
22-16 AWG SOLID OR STRANDED	22-16 AWG SOLID OR STRANDED	22-16 AWG SOLID OR STRANDED

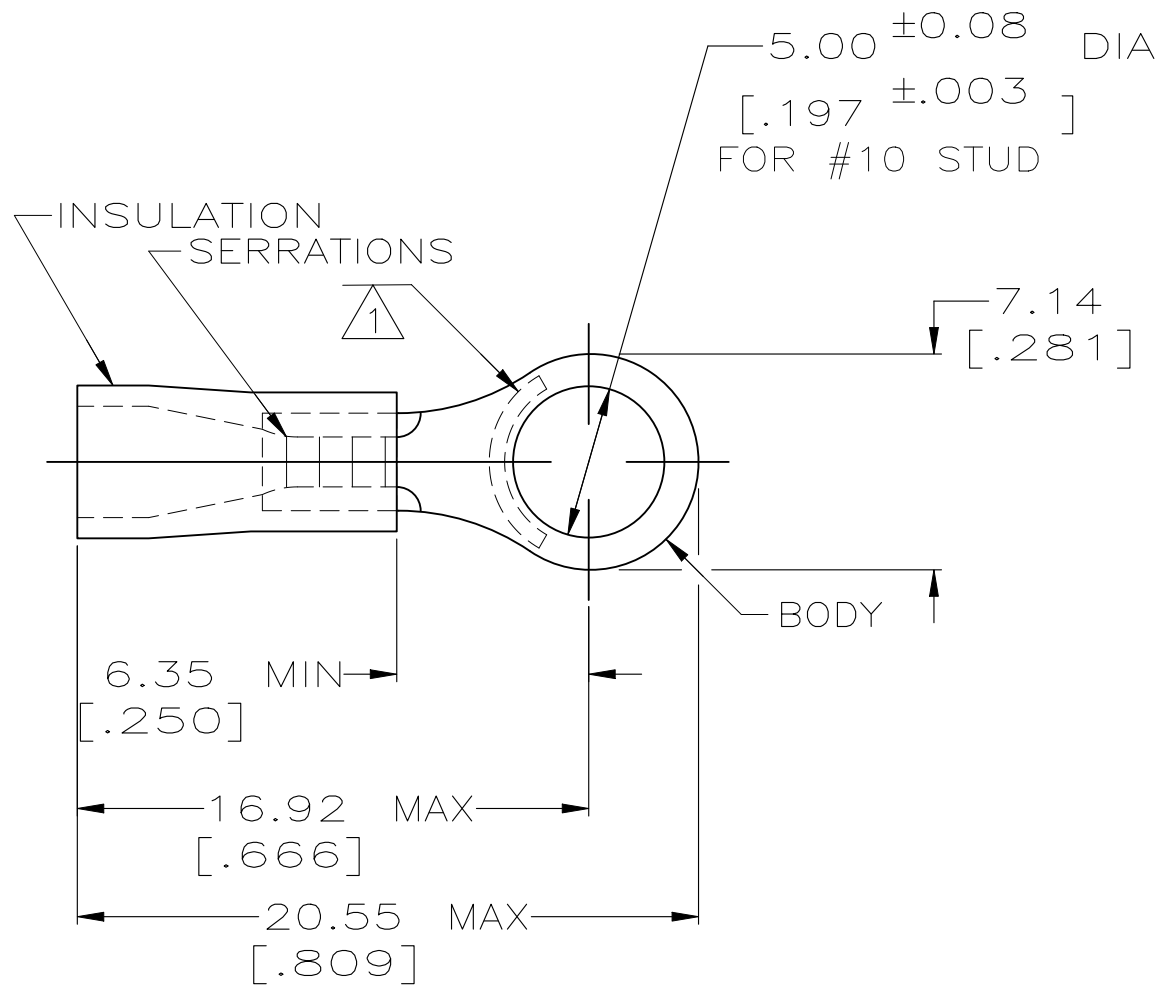

- 1 STAMP AMP 22-16* APPROX AS SHOWN
22-16 TERMINALS ARE STAMPED 22-18 IN
ACCORDANCE WITH MILITARY SPEC SAE AS7928
COMMERCIAL WIRE RANGE IS 22-16
- 2 WIRE INSULATION DIA: 2.67-3.56 [.105-.140]
- 3 TONGUE MATERIAL THK: 0.79^{±0.05} [.031^{±.002}]
- 4 MATERIAL: BODY - CU PER ASTM B152
SLEEVE - PVC, COLOR - RED
- 5 MATERIAL: BODY - CU PER ASTM B152
SLEEVE - PVC, COLOR - BLACK
- 6 NOTE DELETED

100	LOOSE PC,BOX	4	8-34146-1
1 KIT = 250 PIECES	LOOSE PIECE	4	6-34146-0
5000	ON TAPE, REEL	5	2-34146-5
1000	LOOSE PIECE	5	2-34146-4
5000	ON TAPE, REEL	4	2-34146-1
1000	LOOSE PIECE	4	34146
QTY	PACKAGE TYPE		PART NO.

AMP INCORPORATED CUSTOMER SERVICE SYSTEMS	
FOR ADDITIONAL PRODUCT INFORMATION OR COPIES OF DRAWINGS AND TECHNICAL DOCUMENTS	PRODUCT INFORMATION CENTER 1-800-522-6752
FOR APPLICATION TOOLING INFORMATION	TOOLING ASSISTANCE CENTER 1-800-722-1111
FOR ORDER ENTRY	1-800-526-5142

MAX RECOMMENDED OPERATING TEMPERATURE: 105°C [221°F]
VOLTAGE RATING: 600V MAX (1000V FIXTURE OR SIGN)
CIRCULAR MIL AREA: 0.26-1.65mm ² [509-3260] SOLID OR STRANDED

THIS DRAWING IS A CONTROLLED DOCUMENT.	
DIMENSIONS: INCHES	TOLERANCES UNLESS OTHERWISE SPECIFIED:
	0 PLC ± - 1 PLC ± - 2 PLC ± 0.20[.008] 3 PLC ± - 4 PLC ± - ANGLES ± -
MATERIAL SEE NOTES	FINISH TIN PER ASTM B545

DWN DK SCHRUM	08/06/92
CHK RE HERSEY	11/10/92
APVD M BARNABA	11/10/92
PRODUCT SPEC UL 486A	
APPLICATION SPEC	
WEIGHT	-

TE Connectivity			
NAME TERMINAL, RING TONGUE, PLASTI-GRIP, WIRE SIZE: 22-16 AWG			
SIZE	CAGE CODE	DRAWING NO	RESTRICTED TO
A3	00779	C-34146	-
CUSTOMER DRAWING		SCALE 4:1	SHEET 1 OF 1 REV U3