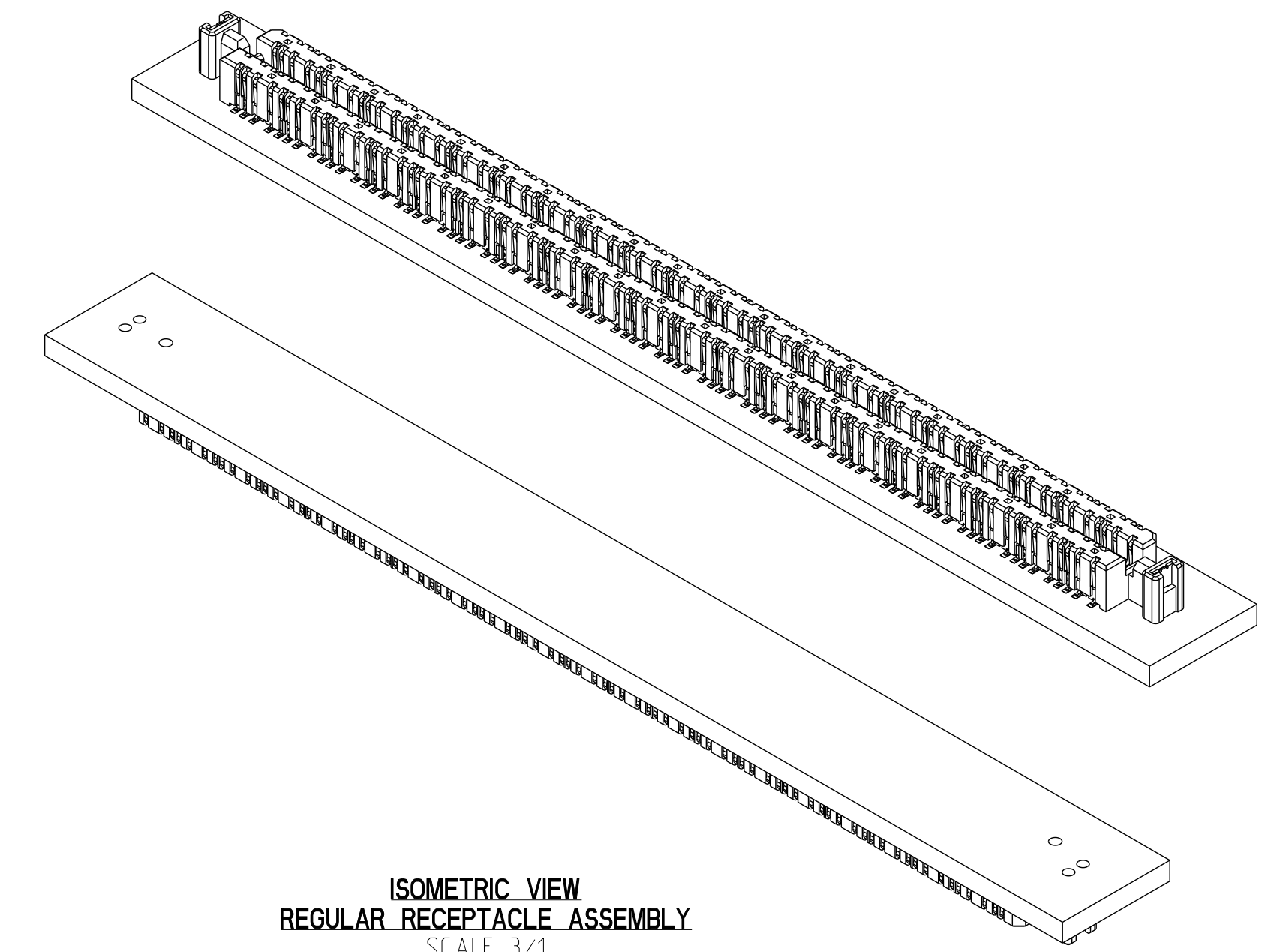

TABLE-1: WITH LOSSY OPTION						
PART NUMBER	DESCRIPTION	A	B	C	N	
IC13427-011Z	VERTICAL RECEPTACLE ASSEMBLY, 12 POSITION, REGULAR, CONDUCTIVE LOSSY	11.67	18.47	7.20	12	
IC13427-013Z	VERTICAL RECEPTACLE ASSEMBLY, 12 POSITION, SHORT, CONDUCTIVE LOSSY	11.67	12.47	7.20	12	
IC13427-021Z	VERTICAL RECEPTACLE ASSEMBLY, 20 POSITION, REGULAR, CONDUCTIVE LOSSY	18.87	25.67	14.40	20	
IC13427-023Z	VERTICAL RECEPTACLE ASSEMBLY, 20 POSITION, SHORT, CONDUCTIVE LOSSY	18.87	19.67	14.40	20	
IC13427-041Z	VERTICAL RECEPTACLE ASSEMBLY, 40 POSITION, REGULAR, CONDUCTIVE LOSSY	36.87	43.67	32.40	40	
IC13427-043Z	VERTICAL RECEPTACLE ASSEMBLY, 40 POSITION, SHORT, CONDUCTIVE LOSSY	36.87	37.67	32.40	40	
IC13427-061Z	VERTICAL RECEPTACLE ASSEMBLY, 60 POSITION, REGULAR, CONDUCTIVE LOSSY	54.87	61.67	50.40	60	
IC13427-063Z	VERTICAL RECEPTACLE ASSEMBLY, 60 POSITION, SHORT, CONDUCTIVE LOSSY	54.87	55.67	50.40	60	
IC13427-081Z	VERTICAL RECEPTACLE ASSEMBLY, 80 POSITION, REGULAR, CONDUCTIVE LOSSY	72.87	79.67	68.40	80	
IC13427-083Z	VERTICAL RECEPTACLE ASSEMBLY, 80 POSITION, SHORT, CONDUCTIVE LOSSY	72.87	73.67	68.40	80	

TABLE-2: WITH NON-CONDUCTIVE LOSSY OPTION						
PART NUMBER	DESCRIPTION	A	B	C	N	
IC13427-012Z	VERTICAL RECEPTACLE ASSEMBLY, 12 POSITION, REGULAR, NON-COND. LOSSY	11.67	18.47	7.20	12	
IC13427-014Z	VERTICAL RECEPTACLE ASSEMBLY, 12 POSITION, SHORT, NON-COND. LOSSY	11.67	12.47	7.20	12	
IC13427-022Z	VERTICAL RECEPTACLE ASSEMBLY, 20 POSITION, REGULAR, NON-COND. LOSSY	18.87	25.67	14.40	20	
IC13427-024Z	VERTICAL RECEPTACLE ASSEMBLY, 20 POSITION, SHORT, NON-COND. LOSSY	18.87	19.67	14.40	20	
IC13427-042Z	VERTICAL RECEPTACLE ASSEMBLY, 40 POSITION, REGULAR, NON-COND. LOSSY	36.87	43.67	32.40	40	
IC13427-044Z	VERTICAL RECEPTACLE ASSEMBLY, 40 POSITION, SHORT, NON-COND. LOSSY	36.87	37.67	32.40	40	
IC13427-062Z	VERTICAL RECEPTACLE ASSEMBLY, 60 POSITION, REGULAR, NON-COND. LOSSY	54.87	61.67	50.40	60	
IC13427-064Z	VERTICAL RECEPTACLE ASSEMBLY, 60 POSITION, SHORT, NON-COND. LOSSY	54.87	55.67	50.40	60	
IC13427-082Z	VERTICAL RECEPTACLE ASSEMBLY, 80 POSITION, REGULAR, NON-COND. LOSSY	72.87	79.67	68.40	80	
IC13427-084Z	VERTICAL RECEPTACLE ASSEMBLY, 80 POSITION, SHORT, NON-COND. LOSSY	72.87	73.67	68.40	80	

TABLE-3: RETENTION PIN OPTIONS	
PART NUMBER	(L): PROTRUSION BELOW HOUSING
IC13427-0XX0	NO PIN
IC13427-0XX1	1.1MM
IC13427-0XX2	2.5MM

REVISION HISTORY						
ZONE	ECN#	REV	DESCRIPTION	DATE	CHANGED BY	APPROVED
ALL	EC-13407	C	DRAWING UPDATED FOR MODEL CHANGE ADDED NEW TABLE FOR RETENTION PINS	01/06/2020	HCL-MD	M.CHARETH
SH4	EC-13527	D	ADDED PIN OUT EXAMPLE TO SH4	05/27/2020	M.CHARETH	D.MCNAMARA



IC134270- X X Z

POSITION

- 1 = 12
- 2 = 20
- 4 = 40
- 6 = 60
- 8 = 80

ASSEMBLY TYPE

- 1 = REGULAR (WITH GUIDE PINS) & CONDUCTIVE LOSSY
- 2 = REGULAR (WITH GUIDE PINS) & NON-COND. LOSSY
- 3 = SHORT (WITHOUT GUIDE PINS) & CONDUCTIVE LOSSY
- 4 = SHORT (WITHOUT GUIDE PINS) & NON-COND. LOSSY

OPTIONAL RETENTION PIN

- 0 = NO RETENTION PIN
- 1 = SHORT RETENTION PIN
- 2 = LONG RETENTION PIN

- NOTES:
- MATERIAL
HOUSING: HIGH TEMPERATURE LCP, COLOR: BLACK
CONTACT: COPPER ALLOY
CONTACT PLATING: UNDERPLATE WITH NICKEL,
HARD GOLD IN MATING AREA
PURE MATTE TIN ON CONTACT TAIL
 - PLEASE REFER TO PRODUCT SPECIFICATION FOR MECHANICAL AND ELECTRICAL SPECIFICATION.
 - OPTIONAL SOLDERABLE RETENTION PIN
 - PLATED THROUGH HOLE FOR SOLDERABLE RETENTION PIN
RECOMMENDED FINISH: TIN OR OSP

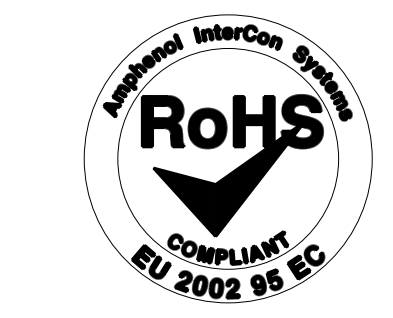

DO NOT SCALE DRAWING UNLESS OTHERWISE SPECIFIED DIMENSIONS & TOLERANCES ARE MILLIMETERS DIMENSIONING PER ASME Y14.5M-2009 TOLERANCES UNLESS SPECIFIED	APPROVALS	DATE
	DRAWN BY: HCL-PV	09/12/2018
	CHK'D BY: M.CHARETH	09/12/2018
	DESIGNED BY: M.CHARETH	09/12/2018
PROCESS ENGINEERING: M.CHARETH	09/12/2018	
THESE DRAWINGS AND SPECIFICATIONS ARE THE PROPERTY OF AMPHENOL CORPORATION AMPHENOL INTERCON - A DIVISION OF AMPHENOL CORPORATION AND SHALL NOT BE REPRODUCED, COPIED OR USED AS THE BASIS FOR THE MANUFACTURE OR SALE OF APPARATUS WITHOUT THE WRITTEN PERMISSION OF AMPHENOL CORPORATION.		
(INSPECTION DIMENSION) (REFERENCE DIMENSION) THIRD ANGLE PROJECTION		

Amphenol InterCon Systems

AMPHENOL INTERCON SYSTEMS INC.
825 OLD TRAIL RD, SUITE A
ETTERS, PA 17319
(717) 915-1400

TITLE:
VERTICAL RECEPTACLE ASSEMBLY

SIZE: D DRAWING NO. **13427C** REV: D

SCALE: 3/1 DWG TYPE: CUSTOMER USE SHEET: 1 OF 4

8 7 6 5 4 3 2 1

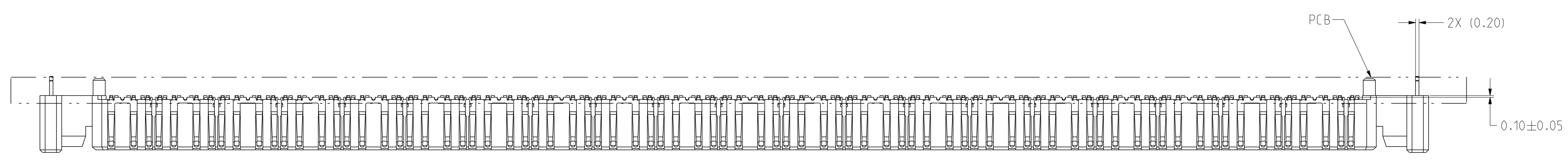
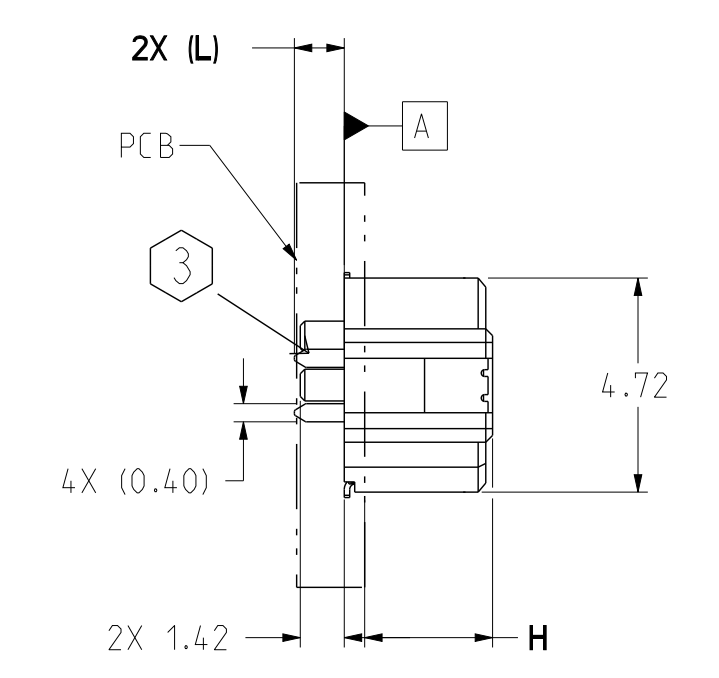
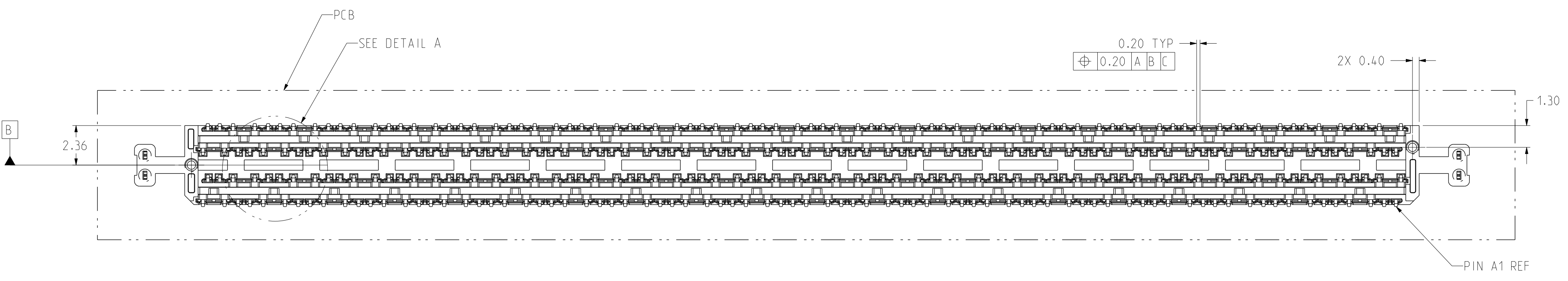
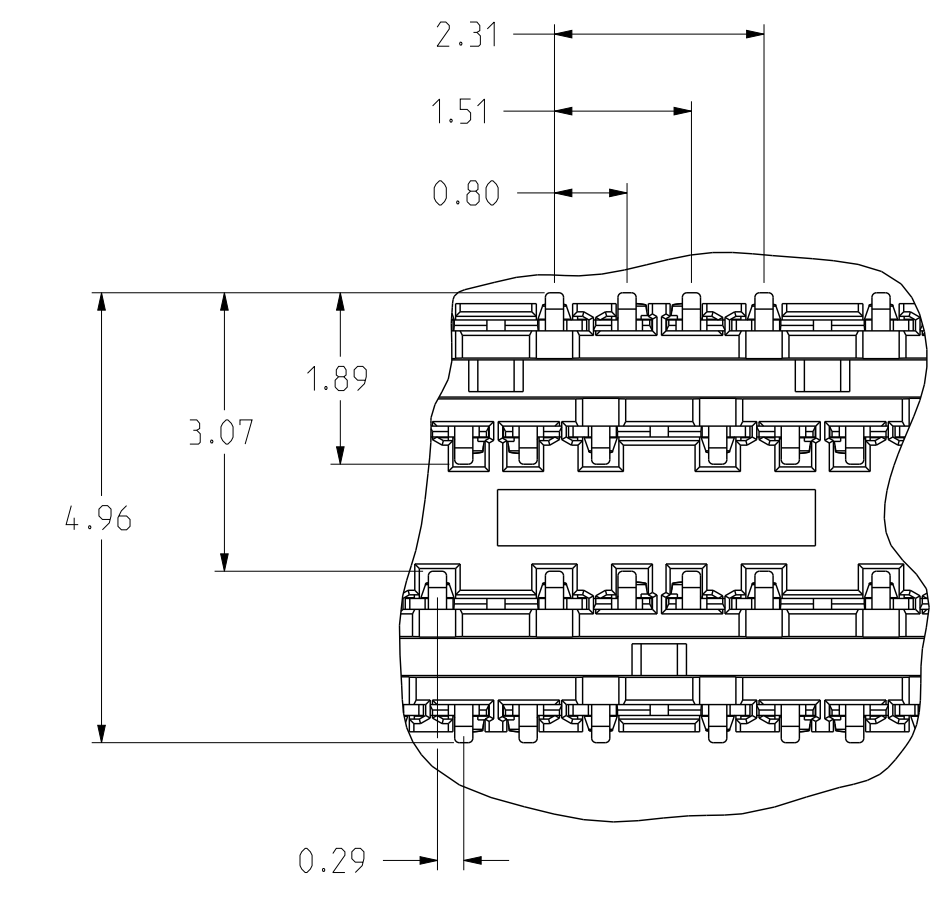
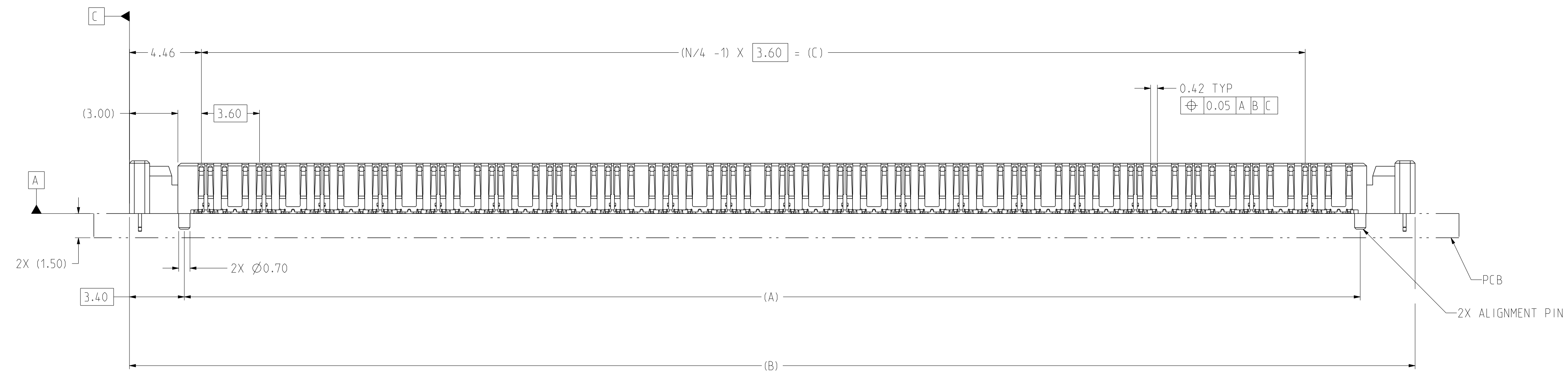

REGULAR RECEPTACLE ASSEMBLY

THESE DRAWINGS AND SPECIFICATIONS ARE THE PROPERTY OF AMPHENOL CORPORATION (AMPHENOL INTERCON - A DIVISION OF AMPHENOL CORPORATION) AND SHALL NOT BE REPRODUCED, COPIED OR USED AS THE BASIS FOR THE MANUFACTURE OR SALE OF APPARATUS WITHOUT THE WRITTEN PERMISSION OF AMPHENOL CORPORATION.

Amphenol
Inter-Con Systems

AMPHENOL INTERCON SYSTEMS INC.
825 OLD TRAIL RD, SUITE A
ETTERS, PA 17319
(717) 915-1400

SIZE	DRAWING NO.	REV
D	13427C	D
SCALE: 3/1	DWG TYPE: XXX	SHEET: 2 OF 4

8 7 6 5 4 3 2 1

8 7 6 5 4 3 2 1

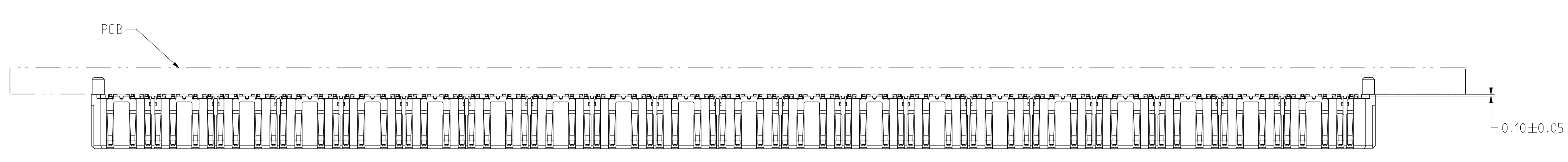
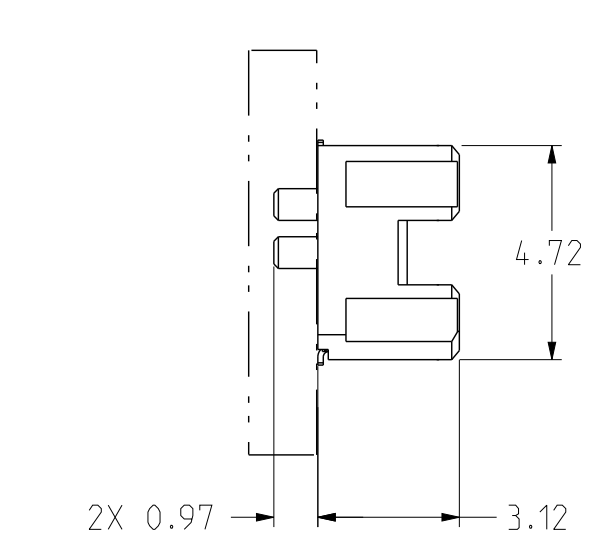
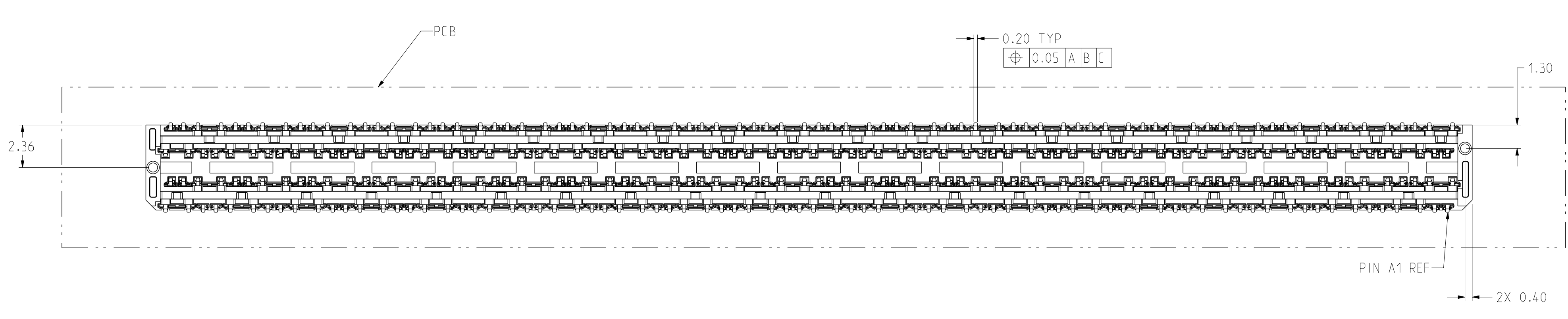
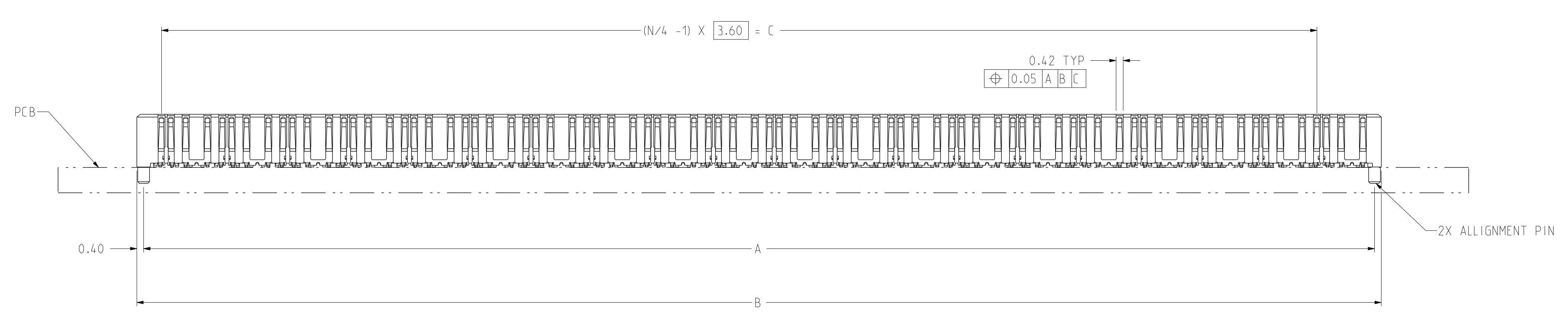

SHORT RECEPTACLE ASSEMBLY

NOTE:

OTHER DIMENSION AND FEATURES WILL REMAIN SAME AS REGULAR VERTICAL RECEPTACLE ASSEMBLY.

THESE DRAWINGS AND SPECIFICATIONS ARE THE PROPERTY OF AMPHENOL CORPORATION (AMPHENOL INTERCON - A DIVISION OF AMPHENOL CORPORATION) AND SHALL NOT BE REPRODUCED, COPIED OR USED AS THE BASIS FOR THE MANUFACTURE OR SALE OF APPARATUS WITHOUT THE WRITTEN PERMISSION OF AMPHENOL CORPORATION.

Amphenol InterCon Systems		AMPHENOL INTERCON SYSTEMS INC. 825 OLD TRAIL RD, SUITE A ETTERS, PA 17319 (717) 915-1400	
SIZE D	DRAWING NO. 13427C	REV D	
SCALE: 3/1	DWG TYPE: XXX	SHEET: 3 OF 4	

8 7 6 5 4 3 2 1

TABLE 4: PC BOARD			
PART NUMBER	N	A	C
IC 13427-01XZ	12	11.67	7.20
IC 13427-02XZ	20	18.87	14.40
IC 13427-04XZ	40	36.87	32.40
IC 13427-06XZ	60	54.87	50.40
IC 13427-08XZ	80	72.87	68.40

LYNX QD PINOUT - PATTERN REPEATS - 12pos SHOWN					
	A	B	C	D	
1	SIG	GND	SIG	GND	1
2	SIG		SIG		SIG
3	GND	SIG	GND	SIG	3
4		SIG		SIG	4
5	SIG	GND	SIG	GND	5
6	SIG		SIG		SIG
7	GND	SIG	GND	SIG	7
8		SIG		SIG	SIG
9	SIG	GND	SIG	GND	9
10	SIG		SIG		SIG
11	GND	SIG	GND	SIG	11
12		SIG		SIG	SIG
	A	B	C	D	

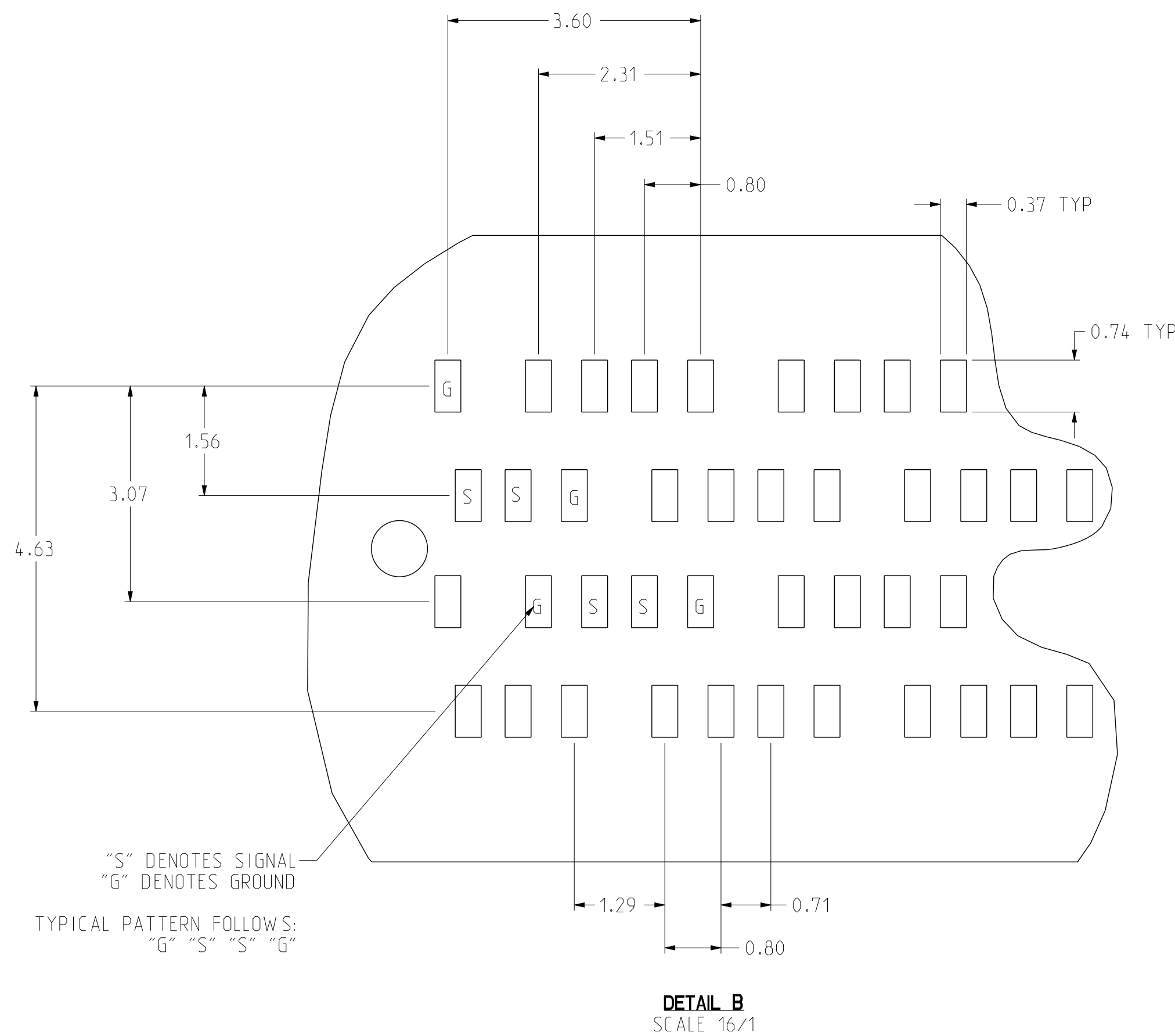
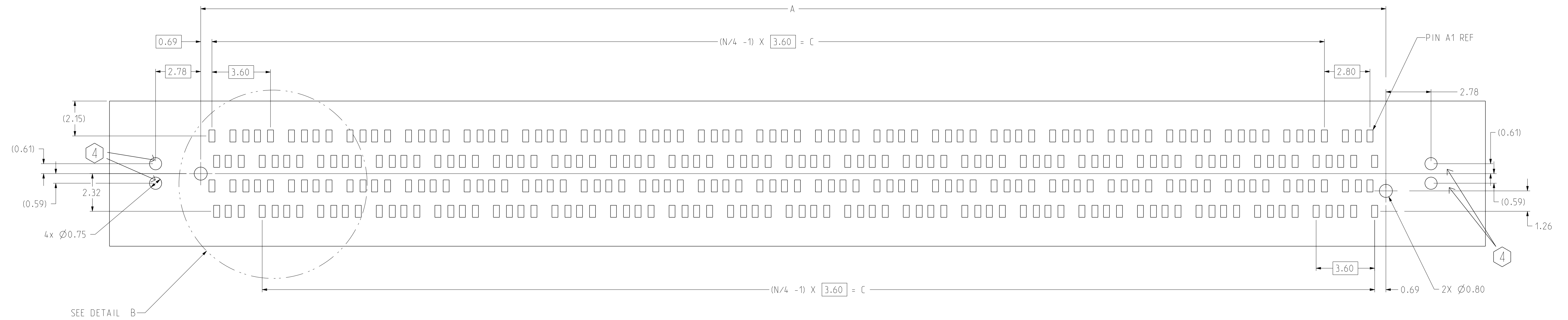

Amphenol
InterCon
Systems

AMPHENOL INTERCON SYSTEMS INC.
825 OLD TRAIL RD, SUITE A
ETTERS, PA 17319
(717) 915-1400

SIZE	DRAWING NO.	REV
D	13427C	D
SCALE: 3/1	DWG TYPE: XXX	SHEET: 4 OF 4