

| P | LTR | DESCRIPTION                                  | DATE      | DWN | APVD |
|---|-----|--|-----------|-----|------|
| K |     | REV PER EC 0G3C-0525-04                      | 05OCT04   | MB  | JO   |
| L |     | RIB FEATURE IS ADDED IN THE STANDOFF FEATURE | 20MAR2026 | LS  | GVP  |

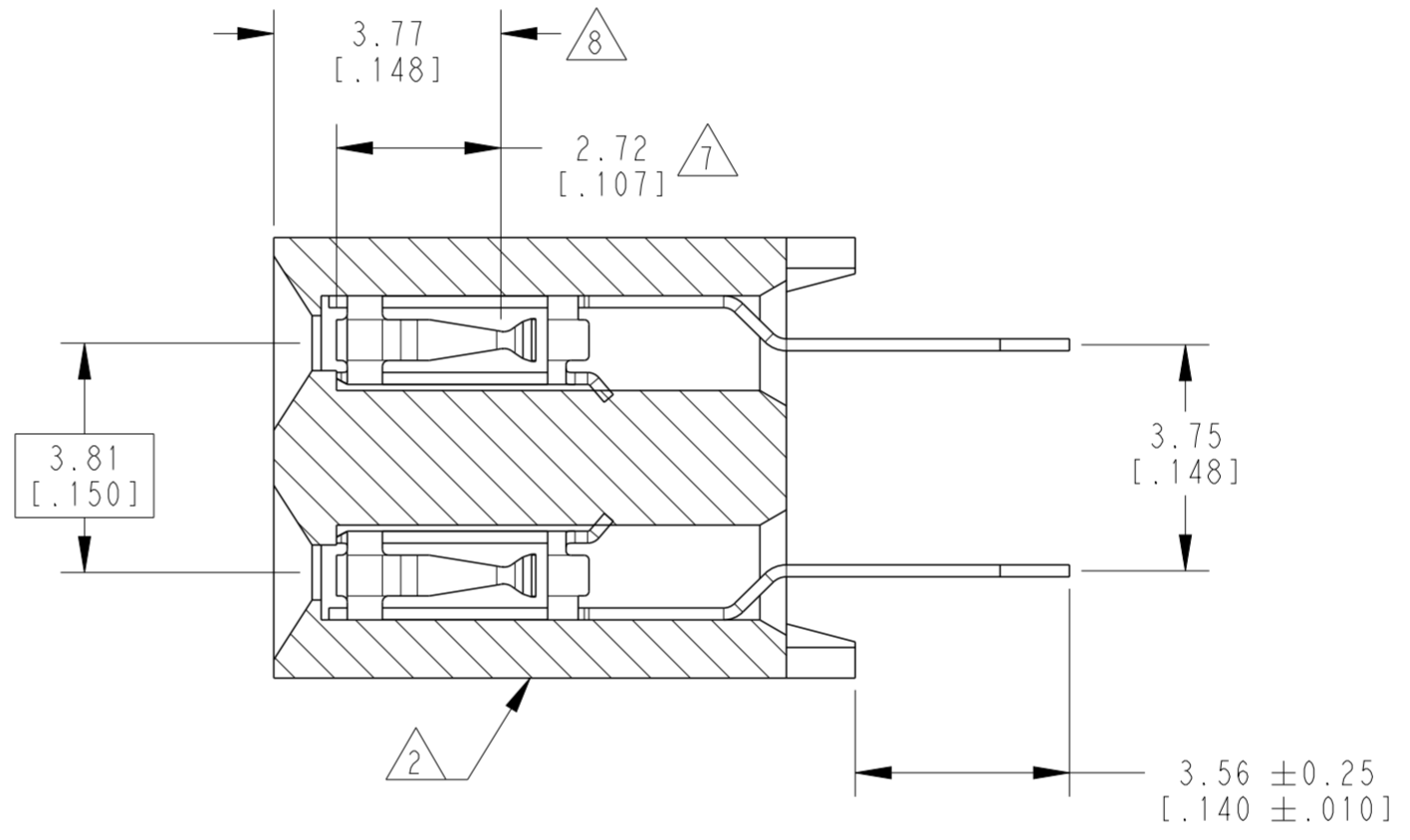
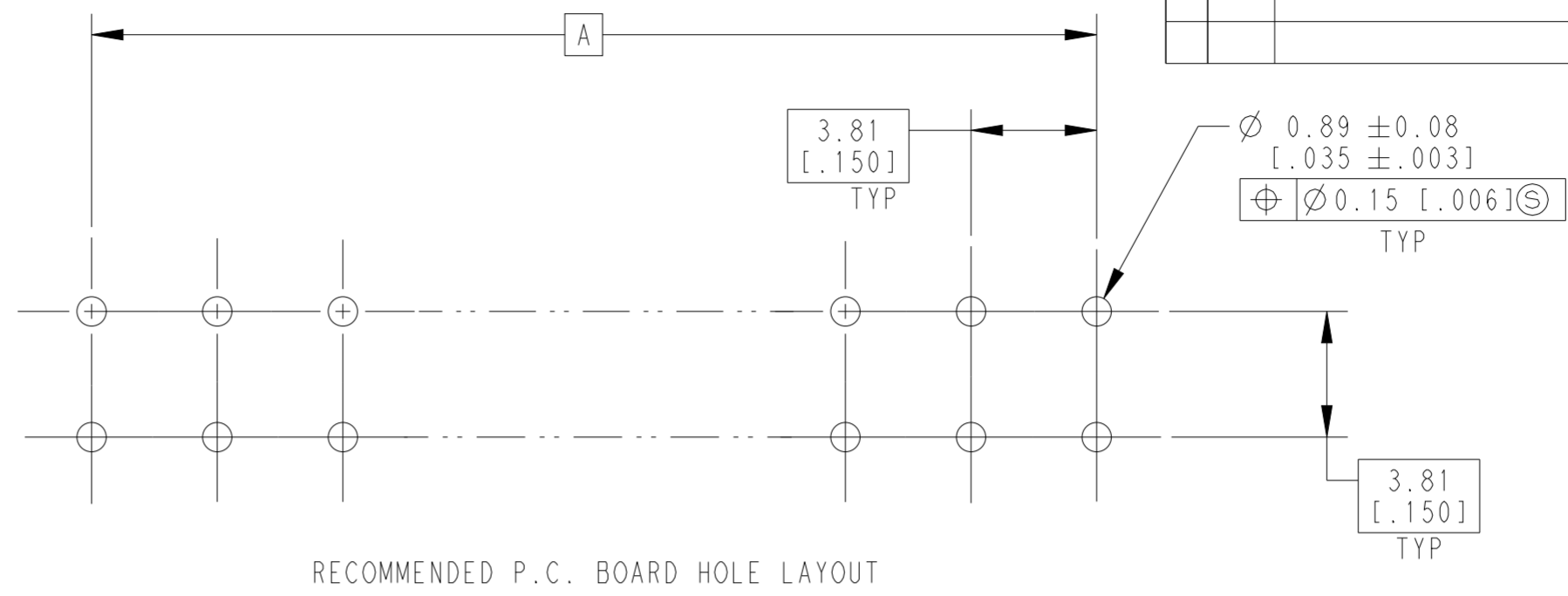
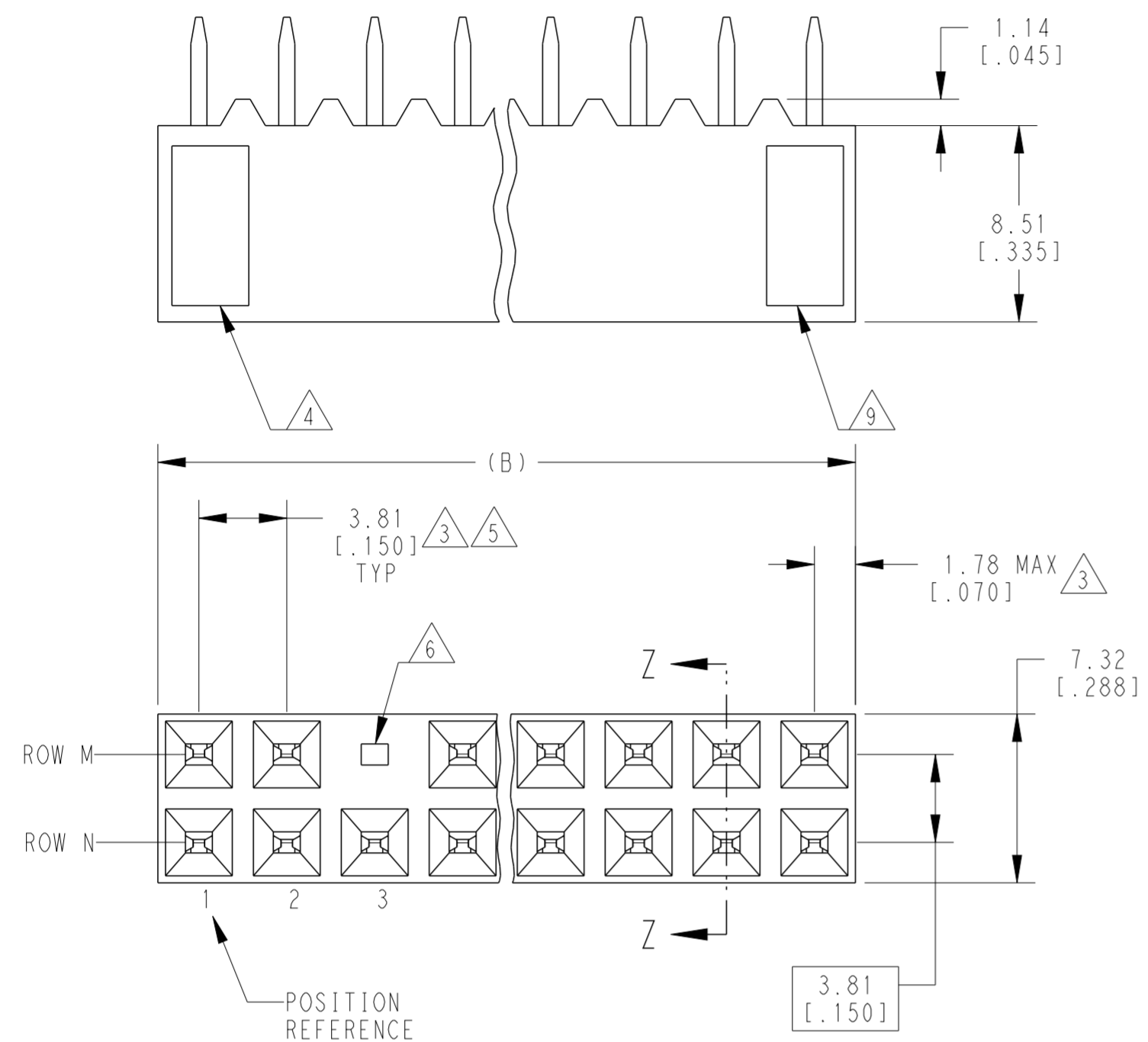

SECTION Z-Z  
SCALE 8:1

- 1 HOUSING: FLAME RETARDANT, GLASS FILLED, THERMOPLASTIC, COLOR: BLACK. CONTACT: PHOSPHOR BRONZE
- 2 CONTACT: DUPLEX PLATED 0.00076[.000030] GOLD IN CONTACT AREA, 0.00381-0.00762[.000150 - .000300] BRIGHT TIN-LEAD ON LEADS ALL OVER 0.00127[.000050] NICKEL
- 3 THESE DIMENSIONS PERTAIN TO CAVIITY CENTERLINES ONLY - NOT TO CONTACT LOCATIONS
- 4 PART NUMBER AND DATE CODE ARE MARKED IN APPROXIMATE LOCATION SHOWN.
- 5 TOLERANCE IS NON-CUMULATIVE.
- 6 KEY IN POSITION, NO CONTACT CAVITY.
- 7 POINT-OF-MEASUREMENT DIMENSION FOR PLATING THICKNESS (INSIDE CONTACT BEAM).
- 8 POINT-OF-CONTACT DIMENSION.
- 9 TYCO LOGO AND CSA LOGO ARE MOLDED INTO HOUSING.
- 10 NO POSITION NUMBER MARKING REQUIRED FOR THIS PART.

|          |                       |       |       |                               |                  |    |          |               |                |
|----------|-----------------------|-------|-------|-------------------------------|------------------|----|----------|---------------|----------------|
|          | 12                    | 2     | 2     | 26.67<br>[1.050]              | 22.86<br>[.900]  | 14 | 533034-3 |               |                |
| OBSOLETE | 15                    | 3     | NONE  | 30.48<br>[1.200]              | 26.67<br>[1.050] | 16 | 533034-2 |               |                |
| 10       | 6                     | NONE  | NONE  | 11.43<br>[.450]               | 7.62<br>[.300]   | 6  | 533034-1 |               |                |
|          | NO OF<br>ACTV<br>POSN | ROW M | ROW N | KEYING POSITION<br>NO CONTACT |                  | B  | A        | NO OF<br>POSN | PART<br>NUMBER |

THIS DRAWING IS A CONTROLLED DOCUMENT.

DWN: 5/31/91  
K.L. CLOUSER/UTA  
CHK: 7/30/91  
R. BENDORE

APVD: -

NAME: RECEPTACLE ASSY, MOD II, DBL ROW  
3.81 X 3.81 [.150 X .150] CL,

PRODUCT SPEC: -

APPLICATION SPEC: -

WEIGHT: -

SIZE: A2 CAGE CODE: 00779 DRAWING NO: 533034 RESTRICTED TO: -

MATERIAL: 1 TOLERANCES UNLESS OTHERWISE SPECIFIED: 2

0 PLC ±-  
1 PLC ±-  
2 PLC ±0.13[.005]  
3 PLC ±-  
4 PLC ±-  
ANGLES ±-  
FINISH

CUSTOMER DRAWING SCALE 4:1 SHEET 1 OF 1 REV L