

DF22 Series

7.92mm Contact Pitch High Current Connectors for Internal Power Supplies (UL, C-UL and TÜV Listed)

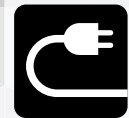

Positive-Lock



Power Supply



Wide Variation



May. 1. 2026 Copyright 2026 HIROSE ELECTRIC CO., LTD. All Rights Reserved.



Features

1. Rated up to 30A

Single position connector can carry current of 30A with 10 AWG conductor. Please refer to Table # 1 for current ratings for multi-position connectors using other conductor sizes.

2. Positive Locking Function

Reliable interior lock protects mated connectors from accidental disconnection.

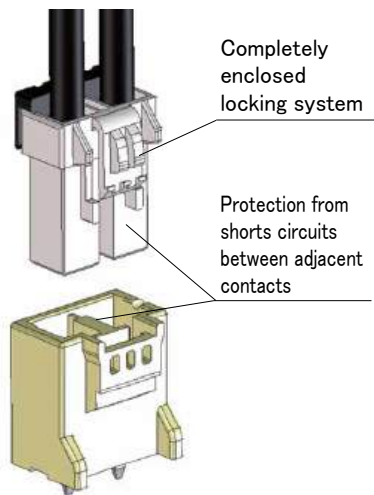

3. Prevention of Incorrect Connections

To prevent incorrect connection when using multiple connectors having the same Number of contacts, 3 product types having different mating configurations are available.

● R Type
(Guide Key: Right Side, Color: Black)

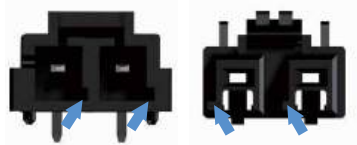

● Standard Type
(Guide Key: Inside, Color: Natural)



● L Type
(Guide Key: Left Side, Color: Red)

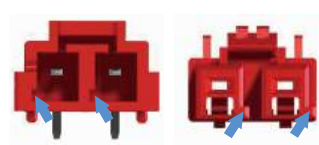

- The image on the left shows the header (the board dipside), the image on the right shows the socket (cable side).
- The guide key position is indicated in position facing the mating surface of the header.

4. Molded-in contact retention tabs

Handling of terminated contacts during the crimping is easier and avoids entangling of wires, since there are no protruding metal tabs.

5. Prevention of incorrect board placement

Built-in posts assure correct connector placement and orientation on the board.

6. Supports resin sealing

Allows potting up to 10mm.

7. Prevention of Short Circuits Between Adjacent Contacts

Each contact is completely surrounded by the housing wall electrically isolating it from adjacent contacts.

8. Increased Retention Force of Crimped Contacts

Can withstand usage methods that result in cable stress.

9. Full Line of Crimp Socket Contacts

Hirose has released DF22C-#S-7.92C which has easy to push/release latch design. and DF22B-#S-7.92C/DF22C-#S-7.92C which has improved electrical insulation properties.

10. In-line Connections

Wire-to-wire connection is also available. Space is saved with 2-row (2×2) layout for 4pos.

11. Branch In-line Type

Branches the power supply lines to reduce wiring. The 4 pos. Branch In-line Type features sequential contact.

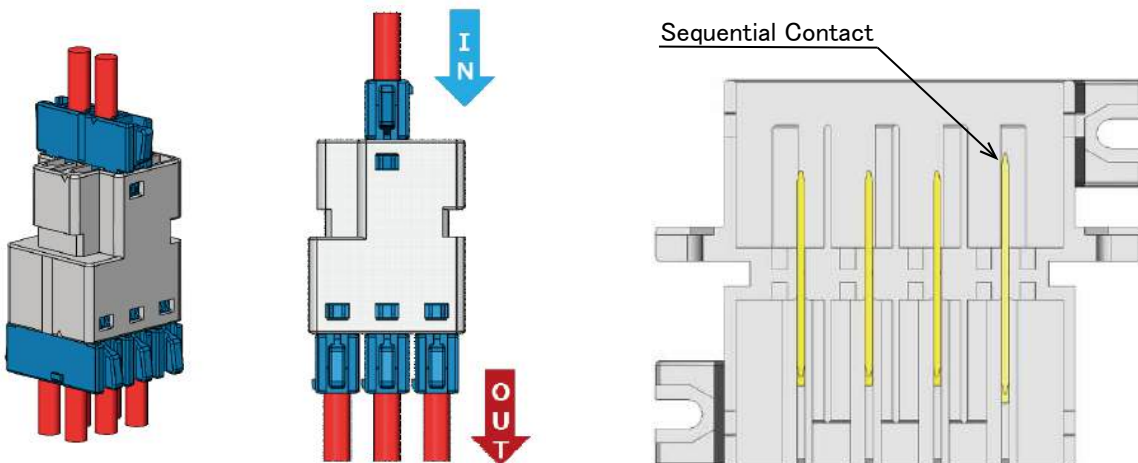

12. UL, C-UL, and TÜV Certified.

13. Glow Wire compliance (Compliant with IEC 60695-2-11)

Product Specifications

Rated Current (Note 1, 4)	No of Pos.	10 AWG	12 AWG	14 AWG	16 AWG	Operating Temperature Range (Note 2)	-55 to +85°C
	1	30A	25A	20A	15A	Storage Temperature Range (Note 3)	-10 to +60°C
	2	25A	20A	18A	15A	Operating Humidity Range	20 to 80%
	3	25A	20A	18A	15A	Storage Humidity Range (Note 3)	40 to 70%
	4	22A	18A	15A	13A		
	5	22A	18A	15A	13A		
Rated Voltage	1,000V AC/DC						

	Rated Current	Rated Voltage
UL	See table above	600V AC/DC
C-UL	See table above	600V AC/DC
TÜV	See table above	600V AC/DC

UL/C-UL/TÜV File No. and Recognition No.

UL: E52653

C-UL: E52653

TÜV: R9950703

Item	Specifications	Conditions
Contact Resistance	No more than 5mΩ	Measured at 1mA and no higher than 20mV
Insulation Resistance	No less than 1,000MΩ	Measured at 1,000V DC
Withstand Voltage	No flashover or breakdown	2,500V AC is applied for 1 minute.
Contact Insertion and Extraction Forces	0.3N Min., 5N Max.	Measured with a steel pin of 1.6 × 0.8 ± 0.002 thickness
Durability	Contact resistance: no more than 10mΩ	30 mating cycles
Vibration Resistance	No electrical discontinuity of 1 μs or greater	Frequency 10 to 55 Hz, single amplitude 0.75 mm, at 2 h, for 3 directions.
Shock Resistance	No electrical discontinuity of 1 μs or greater	Accelerated velocity: 490 m/s ² for 11 ms, half-sine wave in 3 directions, 3 times for each direction
Moisture-Resistance	Contact resistance: no more than 10mΩ	Temperature: 40 ± 2°C ; humidity: 90 to 95% , left as it is for 96 hours
Temperature cycles	Contact resistance: no more than 10mΩ	(-55°C : 30 minutes → 5 to 35°C : 5 minutes → 85°C : 30 minutes → 5 to 35°C : 5 minutes) for 5 cycles
Solder heat Resistance	The resin parts should withstand the temperature and resist melting.	Flow: 260°C , 10 sec Hand soldering: temperature of soldering iron at 300°C for 3 seconds

Note 1: This is the maximum current rating while all pins are powered or used as all power lines. If you split the current over multiple lines, please factor in your own safety margin.

Note 2: Includes temperature rise caused by current flow.

Note 3: The storage condition refers to long-term storage of the product on the shelf before assembly. Please use the operating temperature for temporary storage such as pre-assembly and during shipping.

Note 4: For a branch adapter supports up to 30A when using AWG 10.
For details, please refer to the product specification sheet.

Materials/Finish

Product	Part	Material	Finish	Remarks
Sockets	Insulator	Polyamide	Color: Natural white (Note)	UL94V-0
Crimp Contacts	Contacts	High Conductivity Copper Alloy	Gold Plating	-
Headers	Insulator	Polyamide (Glass Reinforced)	Color: Natural beige (Note)	UL94V-0
	Contacts	High Conductivity Copper Alloy	Gold Plating	-
Adapters	Insulator	Polyamide (Glass Reinforced)	Black	UL94V-0
	Contacts	High Conductivity Copper Alloy	Gold Plating	-

Note: The Standard Colors, colors of the differing coupling forms are black for DF22R and red for DF22L.

Product Number Structure

Refer to the chart below when determining the product specifications from the product number.
Please select from the product numbers listed in this catalog when placing orders.

■ Socket, Header

DF22 B L - 2 S - 7.92 C - #PRT

① ② ③ ④ ⑤ ⑥ ⑦ ⑫

■ Contacts

DF22 A - 1416 SCF A

① ⑧ ⑨ ⑩ ⑪

① Series Name	DF22	⑥ Contact Pitch	7.92mm
② Form Type	Sockets Blank: Standard height, standard lock (Type I) B: Long type, standard lock (Type III) C: Long type, ergonomic lock (Type IV) S: Side lock for Branch SF: Side lock for Branch, finger protection (Note) In-line Plugs Blank: With panel stop A: Without panel stop Branch Adapter B: Flange type BA: Standard type BF: Flange type, finger protection (Note) BAF: Standard type, finger protection (Note)	⑦ Type of Housing	C: Crimp housing DSA: Straight header DS: Right-angle header A: Adapter Blank: Retainer
③ Guide Key Type	Blank: Inside (Color: Natural) R: Right side (Color: Black) L: Left side (Color: Red)	⑧ Applicable Cable	Blank: UL1430 A: UL1015
④ No. of Pos.	1 to 5	⑨ Applicable Conductor	1416: 14 to 16 AWG 1012: 10 to 12 AWG
⑤ Connector Type	S: Socket DS: Double-row socket P: Header EP: In-line plug DEP: Double-row in-line plug RS/P: Retainer	⑩ Packaging	SCF: Socket contacts / reel SC: Socket contacts / bag PCF: In-line plug contacts / reel PC: In-line plug contacts / bag
		⑪ Plating Specifications	A: Gold Plating
		⑫ No. of Ports	PRT: PORT

Note: Finger protection is available only for IEC standards.

Diagram of Connector Mating Combinations

● Wire-to-Board Connection

Crimp socket (Note 2)	Crimp contact for Socket	Retainer (Note 1)			
DF22#-#S-7.92C	DF22(A)-#SC(F)A	DF22#-#RS/P-7.92	<table border="1"> <tr> <td>Straight pin header (Note 2)</td> </tr> <tr> <td>DF22#-#P-7.92DSA</td> </tr> </table>	Straight pin header (Note 2)	DF22#-#P-7.92DSA
Straight pin header (Note 2)					
DF22#-#P-7.92DSA					

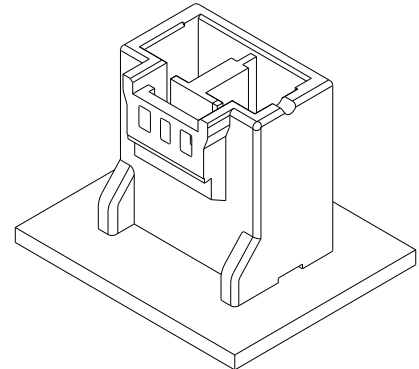
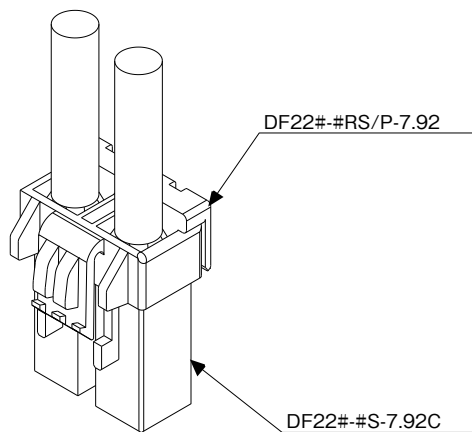

Right angle pin header (Note 2)
DF22#-#P-7.92DS

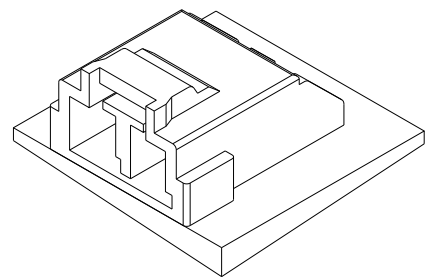

● In-line or Wire-to-Wire Connection

In-line plug	Crimp contact for in-line plug	Retainer (Note 1)
DF22#-#EP-7.92C	DF22(A)-#PC(F)A	DF22B/C-#RS/P-7.92

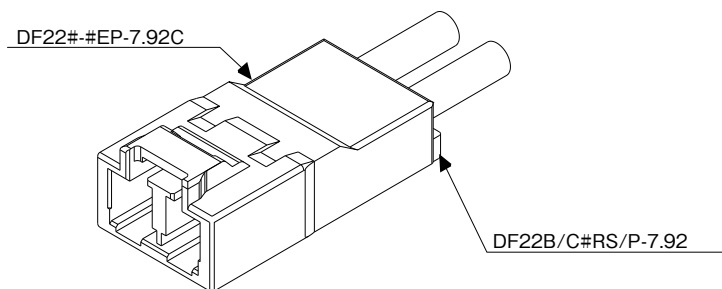

Note 1: Since this product uses thick wires, a larger load is applied to the connector when inserting/extracting or routing the wires. Please use a retainer to reduce the load on the connector.

Crimp socket	Applicable Retainer	In-line plug	Applicable Retainer
DF22-#S-7.92C	DF22-#RS/P-7.92	DF22-#EP-7.92C	DF22B/C-#RS/P-7.92
DF22B-#S-7.92C	DF22B/C-#RS/P-7.92	DF22A-#EP-7.92C	
DF22C-#S-7.92C			

Note 2: The key difference (L, R) product matches the mating connector of the same key (L, R).

Branch Crimp Socket (Note 3)	Socket Contact	↔	Branch Adapter
DF22S-#S-7.92C	DF22(A)-#SC(F)A		DF22B(A)-#EP-7.92A-#PRT

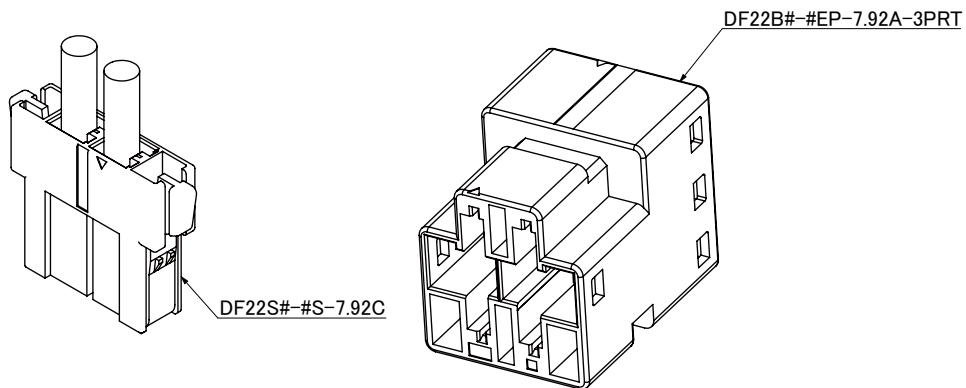

Note 3: This product does not require a retainer.

Crimp Sockets (Standard Height Type)



Shown with terminated and contacts installed.

[1Pos.]

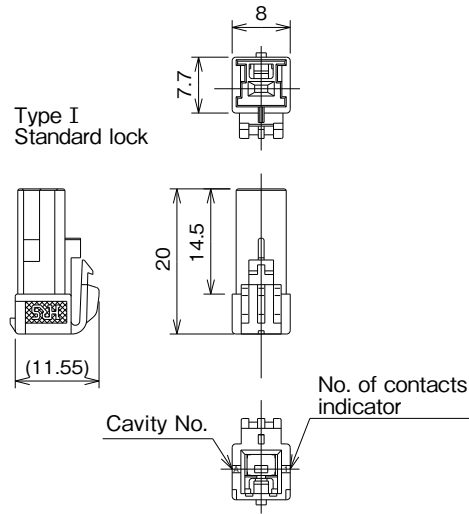

Shown with terminated and contacts installed.

[2 to 5Pos.]

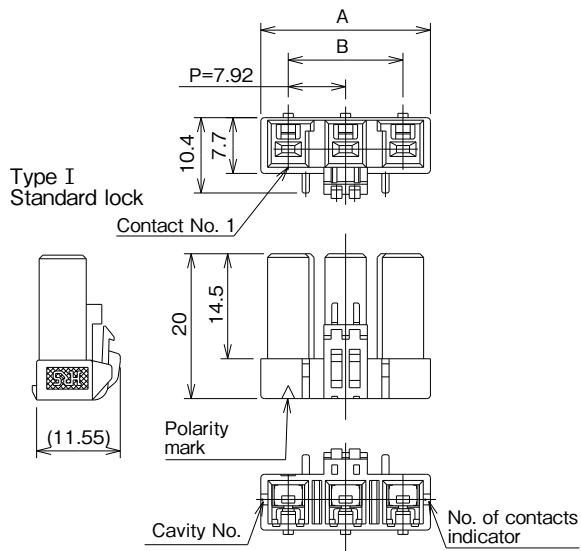

[Type I]

Height: Standard type, Standard lock

Note: The part number and HRS No. have changed to reflect the product form change of the 2 to 5 pos. types.

Standard Type (Guide Key: Inside, Color: White)

Unit : mm

Part No.	HRS No.	No. of Pos.	A	B	Purchase Unit
DF22-1S-7.92C(28)	CL0680-1012-2-28	1	8.00	-	100pcs per bag
DF22-2S-7.92C(28)	CL0680-1004-4-28	2	15.50	7.92	
DF22-3S-7.92C(28)	CL0680-1005-7-28	3	23.42	15.84	
DF22-4S-7.92C(28)	CL0680-1006-0-28	4	31.34	23.76	
DF22-5S-7.92C(28)	CL0680-1007-2-28	5	39.26	31.68	

R Type (Guide Key: Right Side, Color: Black)

Unit : mm

Part No.	HRS No.	No. of Pos.	A	B	Purchase Unit
DF22R-1S-7.92C(28)	CL0680-1026-7-28	1	8.00	-	100pcs per bag
DF22R-2S-7.92C(28)	CL0680-1027-0-28	2	15.50	7.92	
DF22R-3S-7.92C(28)	CL0680-1028-2-28	3	23.42	15.84	
DF22R-4S-7.92C(28)	CL0680-1029-5-28	4	31.34	23.76	
DF22R-5S-7.92C(28)	CL0680-1030-4-28	5	39.26	31.68	

L Type (Guide Key: Left Side, Color: Red)

Unit : mm

Part No.	HRS No.	No. of Pos.	A	B	Purchase Unit
DF22L-1S-7.92C(28)	CL0680-1031-7-28	1	8.00	-	100pcs per bag
DF22L-2S-7.92C(28)	CL0680-1032-0-28	2	15.50	7.92	
DF22L-3S-7.92C(28)	CL0680-1033-2-28	3	23.42	15.84	
DF22L-4S-7.92C(28)	CL0680-1034-5-28	4	31.34	23.76	
DF22L-5S-7.92C(28)	CL0680-1035-8-28	5	39.26	31.68	

Note: Every even number position has a different locking design.

Crimp Sockets (Height, Long Type)



Shown with terminated and contacts installed.

[1Pos.]

Type IV
Height: Long type,
user-friendly operation

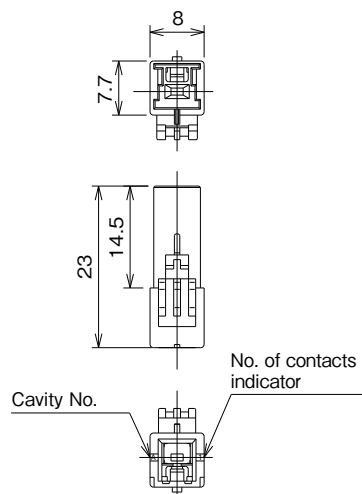
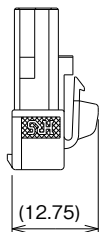

Shown with terminated and contacts installed.

[2, 3Pos.]

Type IV
Height: Long type,
Enhanced
ergonomic lock

Type III
Height: Long type,
Standard lock

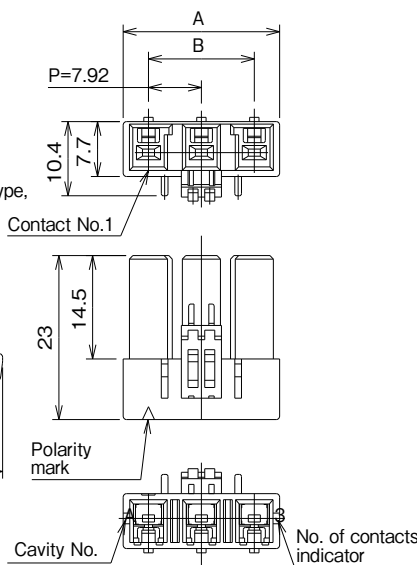
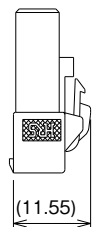
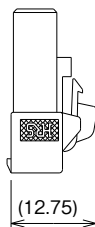

[Type III]

Height: Long type, Standard lock

Standard Type (Guide Key : Inside, Color : White)

Unit : mm

Part No.	HRS No.	No. of Pos.	A	B	Purchase Unit
DF22B-2S-7.92C	CL0680-1097-5-00	2	15.50	7.92	100pcs per bag
DF22B-3S-7.92C	CL0680-1098-8-00	3	23.42	15.84	

Note: Every even number position has a different locking design.

[Type IV]

Height: Long type, Enhanced ergonomic lock

Standard Type (Guide Key : Inside, Color : White)

Unit : mm

Part No.	HRS No.	No. of Pos.	A	B	Purchase Unit
DF22C-2S-7.92C	CL0680-1102-3-00	2	15.50	7.92	100pcs per bag

R Type (Guide Key: Right Side, Color: Black)

Unit : mm

Part No.	HRS No.	No. of Pos.	A	B	Purchase Unit
DF22CR-3S-7.92C	CL0680-1130-9-00	3	23.42	15.84	100pcs per bag

Note: Every even number position has a different locking design.

Crimp Sockets (Branch Adapter, Side Lock Type)

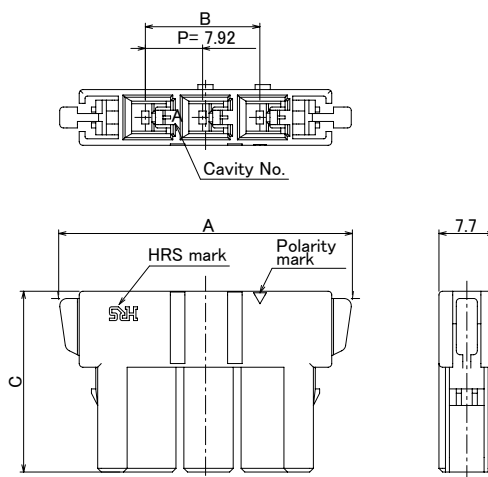

Unit : mm

Part No.	HRS No.	No. of Pos.	A	B	C	Purchase Unit
DF22S-2S-7.92C	CL0680-1219-0-00	2	33.32	-	25	100pcs per bag
DF22S-3S-7.92C	CL0680-1220-0-00	3	41.24	15.84		
DF22SF-4S-7.92C	CL0680-1223-0-00	4	49.16	23.76	28.7	

Branch Adapter

● Standard Type

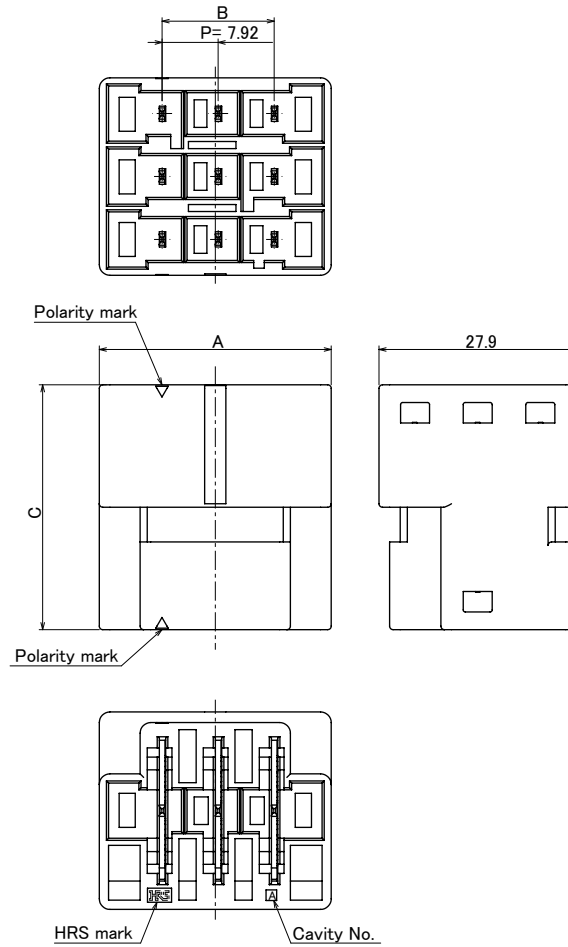

Unit : mm

Part No.	HRS No.	No. of Pos.	A	B	C	Purchase Unit
DF22BA-2EP-7.92A-3PRT	CL0680-1216-0-00	2	24.86	7.92	34.6	50pcs per bag
DF22BA-3EP-7.92A-3PRT	CL0680-1218-0-00	3	32.78	15.84		
DF22BAF-4EP-7.92A-3PRT	CL0680-1222-0-00	4	40.7	23.76	45	30pcs per bag

● Flange Type

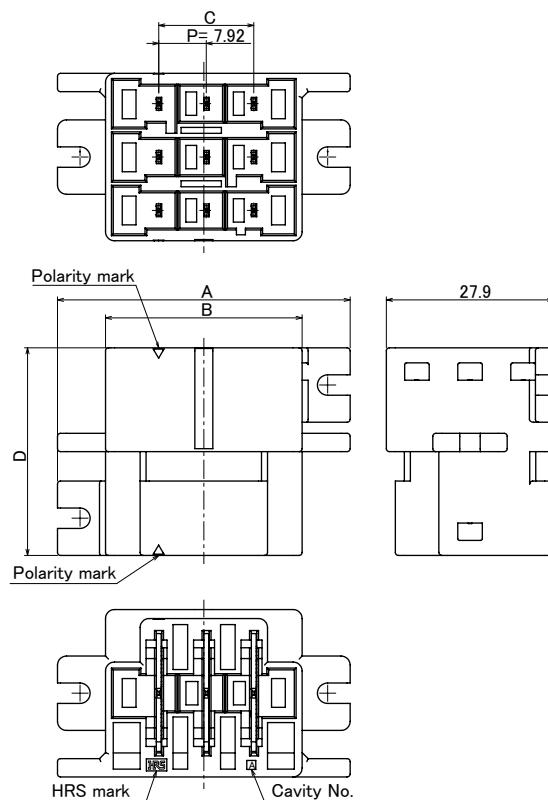

Unit : mm

Part No.	HRS No.	No. of Pos.	A	B	C	D	Purchase Unit
DF22B-2EP-7.92A-3PRT	CL0680-1215-0-00	2	40.86	24.86	7.92	34.6	50pcs per bag
DF22B-3EP-7.92A-3PRT	CL0680-1217-0-00	3	48.78	32.78	15.84		
DF22BF-4EP-7.92A-3PRT	CL0680-1221-0-00	4	56.7	40.70	23.76	45	30pcs per bag

■ Panel Cutout

[2Pos.]

■ Panel Mount Fixed

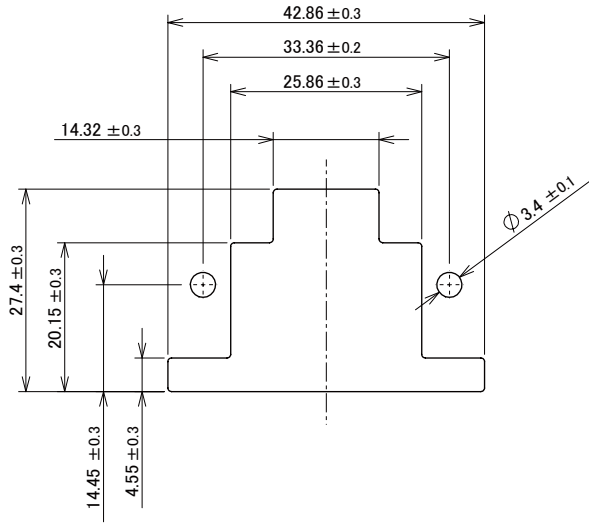

■ Housing Installation Fixed

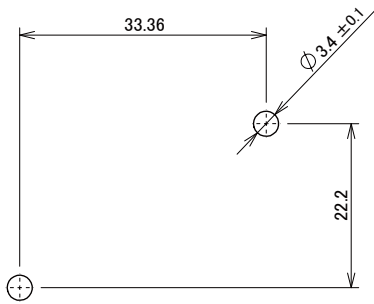

[3Pos.]

■ Panel Mount Fixed

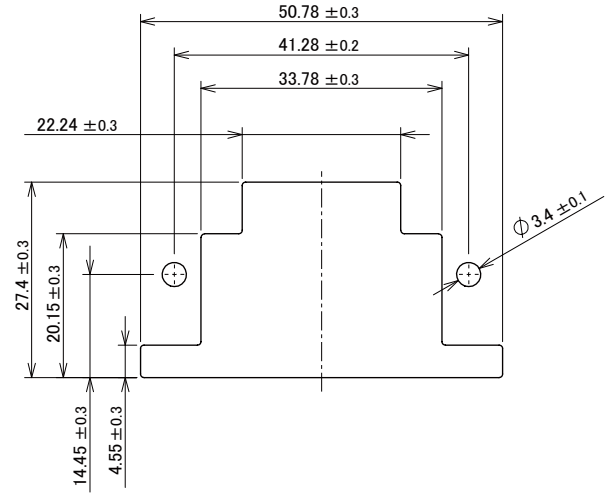

■ Housing Installation Fixed

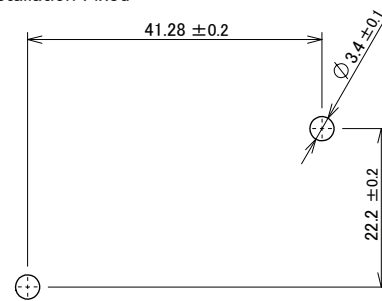

[4Pos.]

■ Panel Mount Fixed

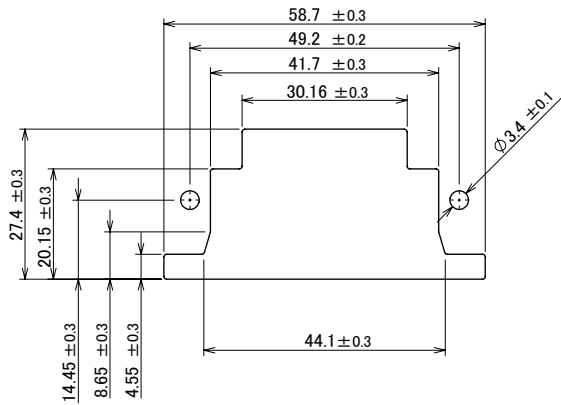

■ Housing Installation Fixed

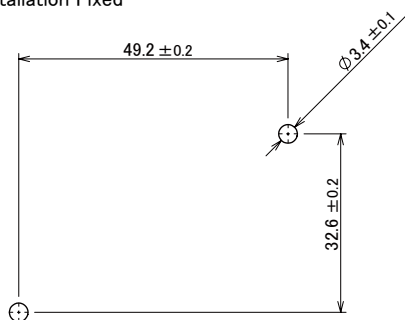

Straight Header



[1Pos.]

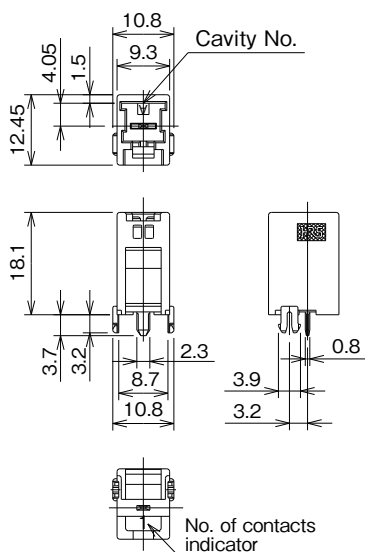

[2 to 5Pos.]

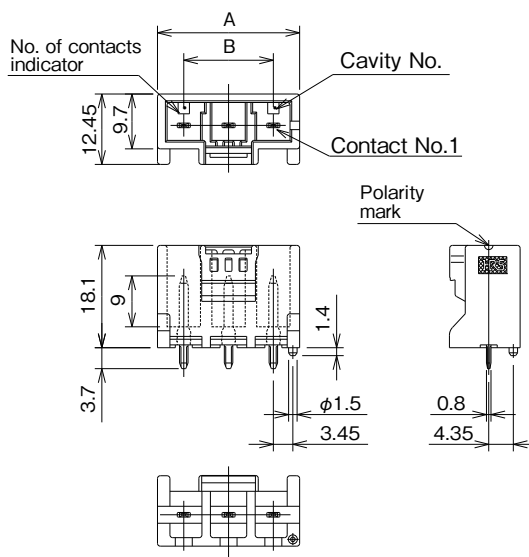

Standard Type (Guide Key: Inside, Color: Natural Beige)

Unit : mm

Part No.	HRS No.	No. of Pos.	A	B	Bag Packaging	Tray Packaging
DF22-1P-7.92DSA(##)	CL0680-1013-5-##	1	-	-	-	○
DF22-2P-7.92DSA(##)	CL0680-1014-8-##	2	17.22	7.92	○	-
DF22-3P-7.92DSA(##)	CL0680-1015-0-##	3	25.14	15.84	○	-
DF22-4P-7.92DSA(##)	CL0680-1016-3-##	4	33.06	23.76	○	-
DF22-5P-7.92DSA(##)	CL0680-1017-6-##	5	40.98	31.68	○	-

[Specification number (##)] (53): Gold plated, bag packaging / (58): Gold plated, tray packaging (only 1 pos.)

R Type (Guide Key: Right Side, Color: Black)

Unit : mm

Part No.	HRS No.	No. of Pos.	A	B	Bag Packaging	Tray Packaging
DF22R-1P-7.92DSA(##)	CL0680-1036-0-##	1	-	-	-	○
DF22R-2P-7.92DSA(##)	CL0680-1037-3-##	2	17.22	7.92	○	-
DF22R-3P-7.92DSA(##)	CL0680-1038-6-##	3	25.14	15.84	○	-
DF22R-4P-7.92DSA(##)	CL0680-1039-9-##	4	33.06	23.76	○	-
DF22R-5P-7.92DSA(##)	CL0680-1040-8-##	5	40.98	31.68	○	-

[Specification number (##)] (53): Gold plated, bag packaging / (57): Gold plated, tray packaging (only 1pos.)

L Type (Guide Key: Left Side, Color: Red)

Unit : mm

Part No.	HRS No.	No. of Pos.	A	B	Bag Packaging	Tray Packaging
DF22L-1P-7.92DSA(##)	CL0680-1041-0-##	1	-	-	-	○
DF22L-2P-7.92DSA(##)	CL0680-1042-3-##	2	17.22	7.92	○	-
DF22L-3P-7.92DSA(##)	CL0680-1043-6-##	3	25.14	15.84	○	-
DF22L-4P-7.92DSA(##)	CL0680-1044-9-##	4	33.06	23.76	○	-
DF22L-5P-7.92DSA(##)	CL0680-1045-1-##	5	40.98	31.68	○	-

[Specification number (##)] (53): Gold plated, bag packaging / (57): Gold plated, tray packaging (only 1pos.)

Note 1: Bag packaging (100pcs per bag). Order by number of packs.

Note 2: Tray packaging (150pcs per tray). Order by number of 150.

Note 3: Every even number position has a different locking design.

Recommended PCB Layout (Board Thickness: 1.6±0.1)

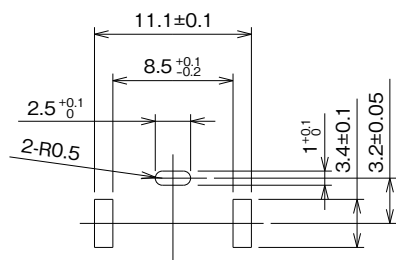
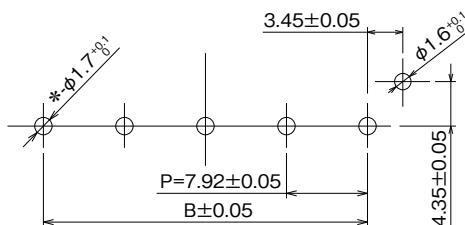
[1Pos.]

[2 to 5Pos.]

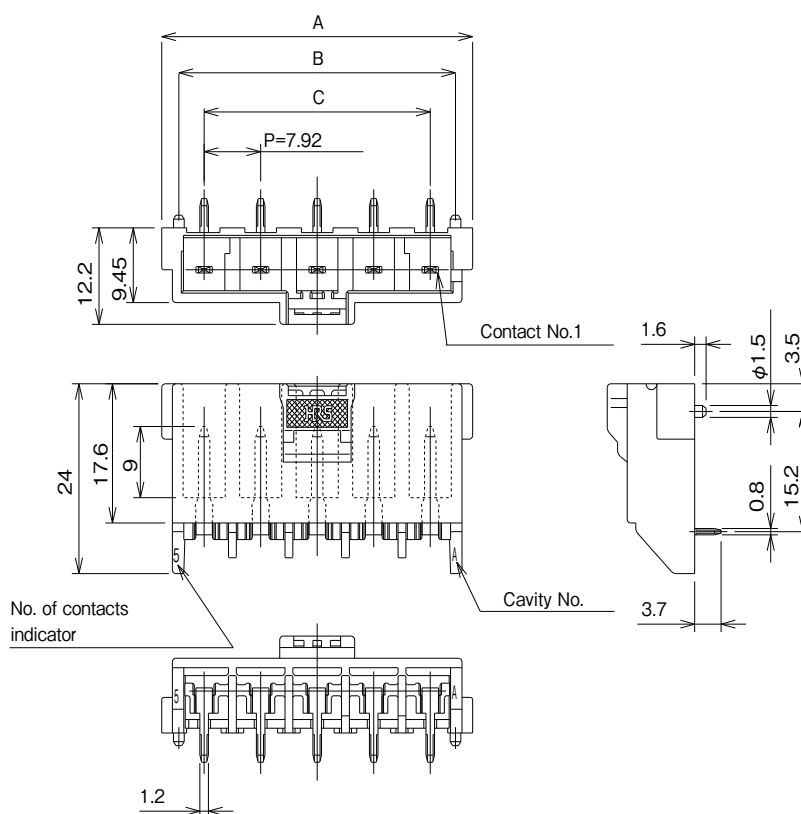
Right Angle Header



Standard Type (Guide Key: Inside, Color: Natural Beige)

Unit : mm

Part No.	HRS No.	No. of Pos.	A	B	C	Purchase Unit
DF22-2P-7.92DS(##)	CL0680-1008-5-##	2	19.80	15.00	7.92	100pcs per bag
DF22-3P-7.92DS(##)	CL0680-1009-8-##	3	27.72	22.92	15.84	
DF22-4P-7.92DS(##)	CL0680-1010-7-##	4	35.64	30.84	23.76	
DF22-5P-7.92DS(##)	CL0680-1011-0-##	5	43.56	38.76	31.68	

R Type (Guide Key: Right Side, Color: Black)

Unit : mm

Part No.	HRS No.	No. of Pos.	A	B	C	Purchase Unit
DF22R-2P-7.92DS(##)	CL0680-1018-9-##	2	19.80	15.00	7.92	100pcs per bag
DF22R-3P-7.92DS(##)	CL0680-1019-1-##	3	27.72	22.92	15.84	
DF22R-4P-7.92DS(##)	CL0680-1020-0-##	4	35.64	30.84	23.76	
DF22R-5P-7.92DS(##)	CL0680-1021-3-##	5	43.56	38.76	31.68	

L Type (Guide Key: Left Side, Color: Red)

Unit : mm

Part No.	HRS No.	No. of Pos.	A	B	C	Purchase Unit
DF22L-2P-7.92DS(##)	CL0680-1022-6-##	2	19.80	15.00	7.92	100pcs per bag
DF22L-3P-7.92DS(##)	CL0680-1023-9-##	3	27.72	22.92	15.84	
DF22L-4P-7.92DS(##)	CL0680-1024-1-##	4	35.64	30.84	23.76	
DF22L-5P-7.92DS(##)	CL0680-1025-4-##	5	43.56	38.76	31.68	

[Specification number (##)] (53): Gold Plated

Note: Every even number position has a different locking design.

■ Recommended PCB Layout (Board Thickness: 1.6 ± 0.1)

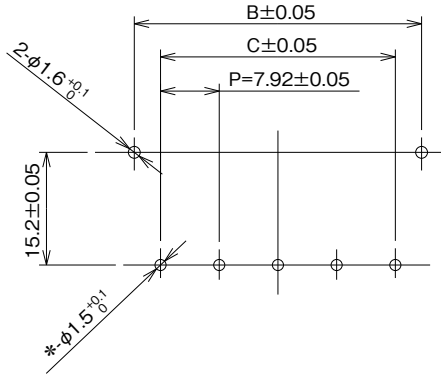

In-line Plug



Shown with terminated and contacts installed.

[1Pos.]

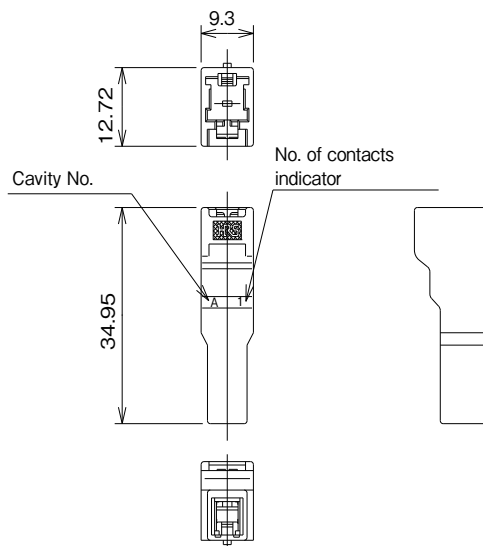

Shown with terminated and contacts installed.

[2, 3Pos.]

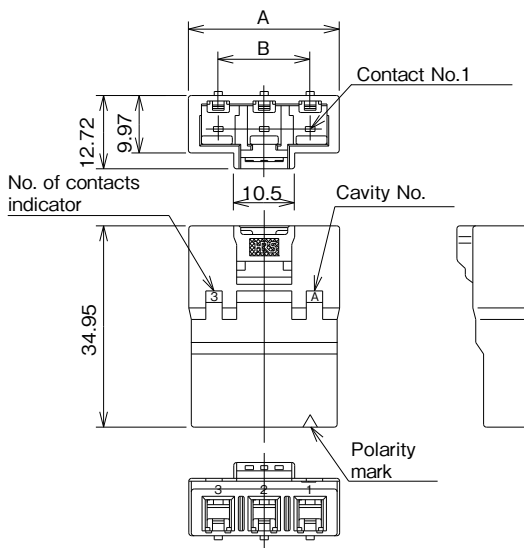

Standard Type (Guide Key: Inside, Color: Natural Beige)

Unit : mm

Part No.	HRS No.	No. of Pos.	A	B	Purchase Unit
DF22A-1EP-7.92C	CL0680-1053-0-00	1	9.30	-	100pcs per bag
DF22A-2EP-7.92C	CL0680-1054-2-00	2	18.00	7.92	
DF22A-3EP-7.92C	CL0680-1055-5-00	3	26.00	15.84	

Note: Every even number position has a different locking design.

In-line Plug (Panel Lock Type)



Shown with terminated and contacts installed.

[1Pos.]

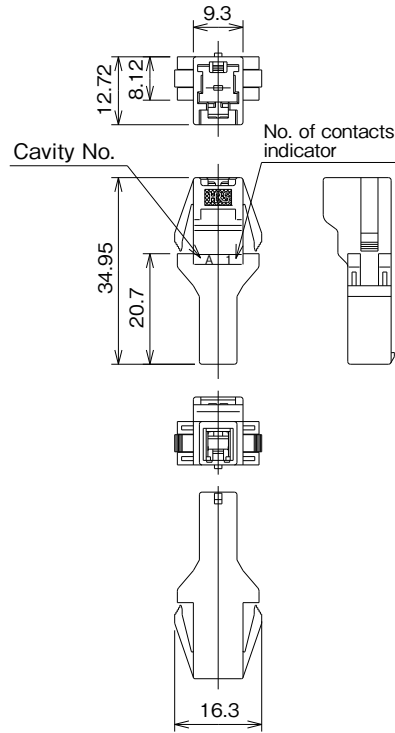

Shown with terminated and contacts installed.

[2, 3Pos.]

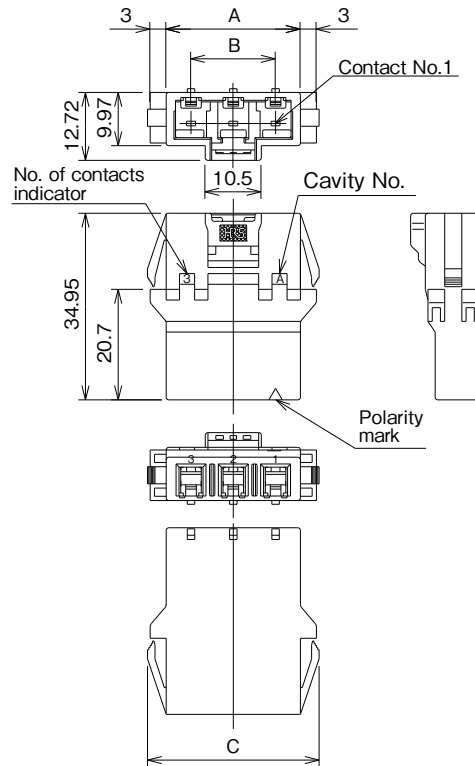

Standard Type (Guide Key: Inside, Color: White)

Unit : mm

Part No.	HRS No.	No. of Pos.	A	B	C	Purchase Unit
DF22-1EP-7.92C	CL0680-1048-0-00	1	9.30	-	16.30	100pcs per bag
DF22-2EP-7.92C	CL0680-1049-2-00	2	17.22	7.92	24.22	
DF22-3EP-7.92C	CL0680-1050-1-00	3	25.14	15.84	32.14	

Note: Every even number position has a different locking design.

■ Panel Cutout

[1Pos.]

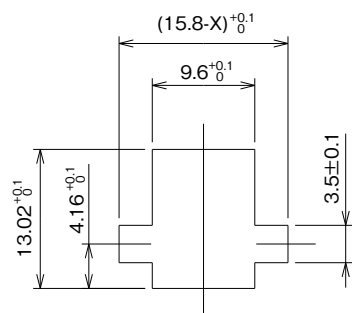

[2, 3Pos.]

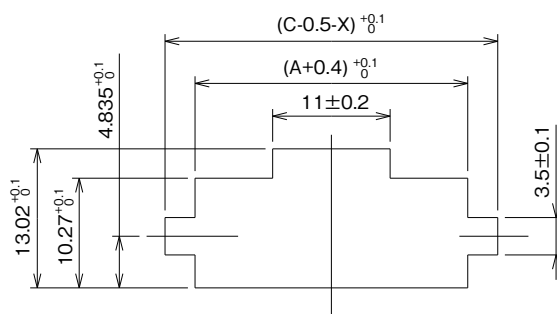

Unit : mm

Panel Thickness	X
2.0	0.48
1.6	0.96
1.2	1.44
0.8	1.92

Note: Do not use a rounded surface at the panel tab portion.

In-line Double-row Socket



Shown with terminated and contacts installed.

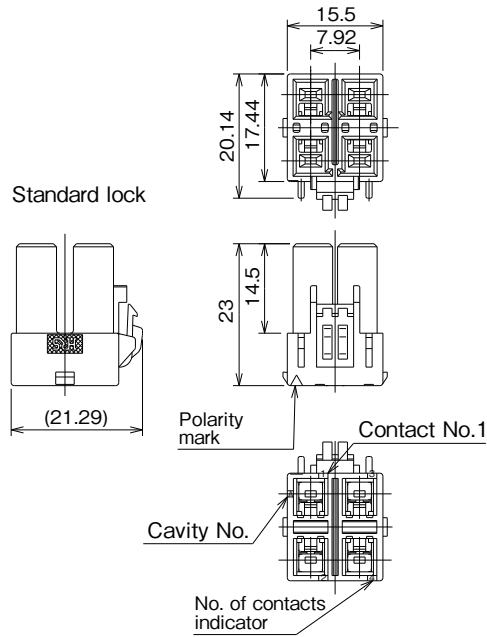

Standard Type (Guide Key: Inside, Color: White)

Unit : mm

Part No.	HRS No.	No. of Pos.	Lock type	Purchase Unit
DF22B-4DS-7.92C	CL0680-1142-8-00	4	Standard lock	100pcs per bag

In-line Double-row Plug

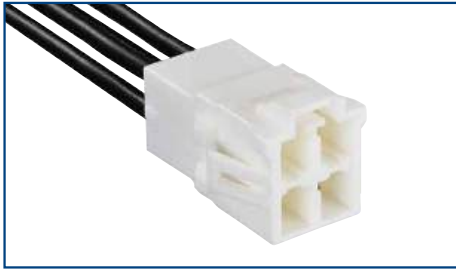

Shown with terminated and contacts installed.

Panel lock type

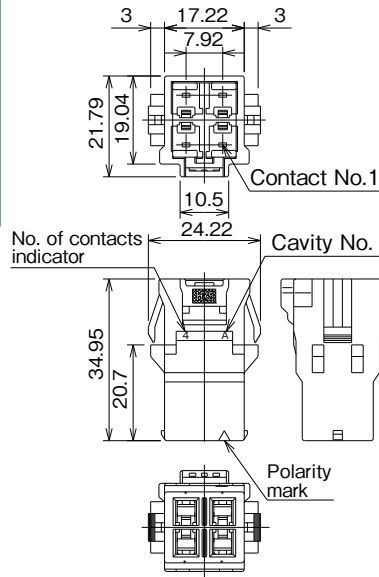

Without panel lock function

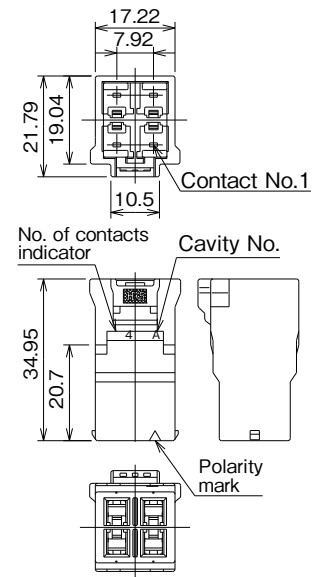

Standard Type (Guide Key: Inside, Color: White)

Unit : mm

Part No.	HRS No.	No. of Pos.	Connector type	Purchase Unit
DF22-4DEP-7.92C	CL0680-1051-4-00	4	Panel lock type	100pcs per bag
DF22A-4DEP-7.92C	CL0680-1056-8-00	4	Without panel lock function	

Recommended Panel Cutout (Panel mount type)

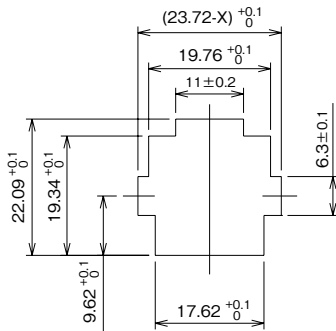

Unit : mm

Panel Thickness	X
2.0	0.48
1.6	0.96
1.2	1.44
0.8	1.92

Note: Do not use a rounded surface at the panel tab portion.

Retainer



[For Standard height, standard lock (Type I)]

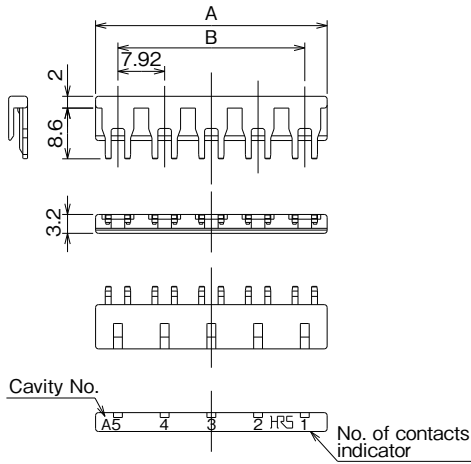

[For Long type, standard lock (Type III)
Long type, enhanced ergonomic lock (Type IV)]

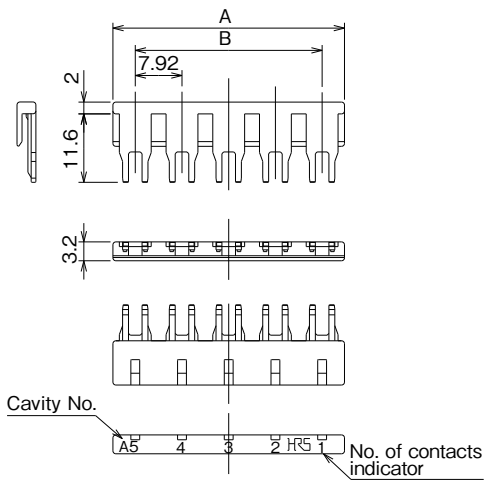

Unit : mm

Part No.	HRS No.	No. of Pos.	A	B	Purchase Unit
DF22-1RS/P-7.92	CL0680-1213-4-00	1	7.04	-	100pcs per bag
DF22-2RS/P-7.92	CL0680-1209-7-00	2	15.50	7.92	
DF22-3RS/P-7.92	CL0680-1210-6-00	3	23.42	15.84	
DF22-4RS/P-7.92	CL0680-1211-9-00	4	31.34	23.76	
DF22-5RS/P-7.92	CL0680-1212-1-00	5	39.26	31.68	
Applicable Socket	DF22-#S-7.92C(28) For Standard height, standard lock(Type I) #indicates number of contacts.				

Unit : mm

Part No.	HRS No.	No. of Pos.	A	B	Purchase Unit
DF22B/C-1RS/P-7.92	CL0680-1214-0-00	1	7.04	-	100pcs per bag
DF22B/C-2RS/P-7.92	CL0680-1200-2-00	2	15.50	7.92	
DF22B/C-3RS/P-7.92	CL0680-1201-5-00	3	23.42	15.84	
DF22B/C-4RS/P-7.92	CL0680-1202-8-00	4	31.34	23.76	
DF22B/C-5RS/P-7.92	CL0680-1203-0-00	5	39.26	31.68	
Applicable Socket	DF22B-#S-7.92C For Long type, standard lock (Type III) DF22C-#S-7.92C Long type, enhanced ergonomic lock (Type IV) DF22-#EP-7.92C DF22A-#EP-7.92C #indicates number of contacts.				

Note: When connecting retainer into the plug housing, please note the cavity numbers will line up numerically,
but the retainer cavity numbers will be upside down compared to the plug cavity numbers.

Crimp Contact for Socket

[For 14 to 16 AWG]

[For 10 to 12 AWG]

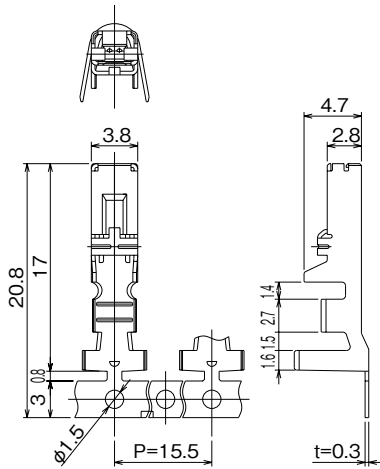

● Strip length: 3.5 to 4.5mm

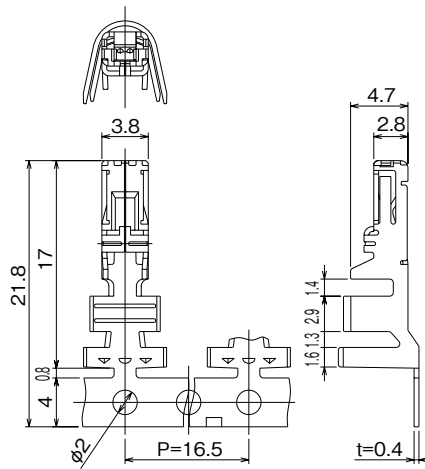

● Strip length: 3.5 to 4.5mm

Reel Contact, Applicable Tool: Applicator

Part No.	HRS No.	Applicable cable					Finish	Purchase Unit
		UL style	AWG	Wire Construction	Sectional area	Jacket diameter		
DF22-1416SCFA	CL0680-1085-6-00	1430	16	26/0.254mm	1.32mm ²	2.4 to 3.0mm	Gold Plated	2,500pcs per reel
DF22A-1416SCFA	CL0680-1087-1-00	1015	14	41/0.26mm	2.18mm ²	3.0 to 3.8mm		2,000pcs per reel
			16	26/0.254mm	1.32mm ²			
DF22A-1012SCFA	CL0680-1106-4-00	1015	10	104/0.26mm	5.52mm ²	3.6 to 4.9mm		
			12	65/0.26mm	3.45mm ²			

Note 1: The conductor of applicable wire is tin plated annealed copper.

Note 2: For applicable cable other than those listed above, refer to Crimp Condition Table. Crimp Condition Table is available from Part No. link.
(If you are using a cable that is not listed in Crimp Condition Table, please contact a Hirose sales representative.)

Bulk Contact, Applicable Tool: Manual Crimping Tool

Part No.	HRS No.	Applicable cable					Finish	Purchase Unit
		UL style	AWG	Wire Construction	Sectional area	Jacket diameter		
DF22-1416SCA	CL0680-1190-0-00	1430	16	26/0.254mm	1.32mm ²	2.6mm	Gold Plated	100pcs per bag
DF22A-1416SCA	CL0680-1191-0-00	1015	14	41/0.26mm	2.18mm ²	3.7mm		
			16	26/0.254mm	1.32mm ²	3.2mm		
DF22A-1012SCA	CL0680-1107-7-00	1015	10	104/0.26mm	5.52mm ²	4.69mm		
			12	65/0.26mm	3.45mm ²	4.04mm		

Note 1: The conductor of applicable wire is tin plated annealed copper.

Note 2: For applicable cable other than those listed above, refer to Crimp Condition Table. Crimp Condition Table is available from Part No. link.
(If you are using a cable that is not listed in Crimp Condition Table, please contact a Hirose sales representative.)

Crimp Contact for In-line Plug

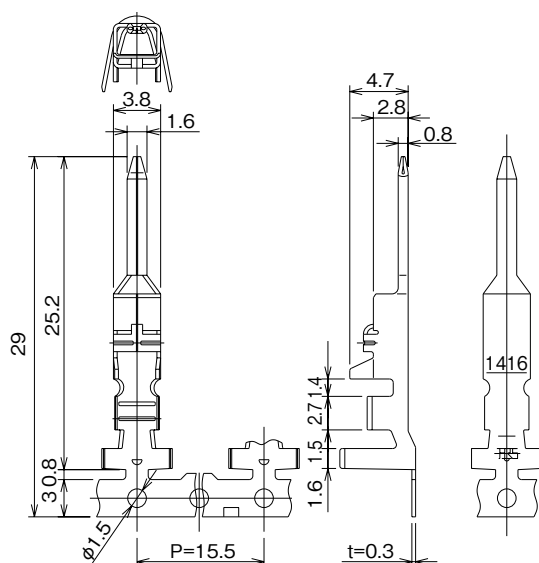

● Strip length: 3.5 to 4.5mm

Reel Contact, Applicable Tool: Applicator

Part No.	HRS No.	Applicable cable					Finish	Purchase Unit
		UL style	AWG	Wire Construction	Sectional area	Jacket diameter		
DF22-1416PCFA	CL0680-2002-4-00	1430	16	26/0.254mm	1.32mm ²	2.4 to 3.0mm	Gold Plated	2,500pcs per reel
DF22A-1416PCFA	CL0680-1194-0-00	1015	14	41/0.26mm	2.18mm ²	3.0 to 3.8mm		2,000pcs per reel
			16	26/0.254mm	1.32mm ²			

Note 1: The conductor of applicable wire is tin plated annealed copper.

Note 2: For applicable cable other than those listed above, refer to Crimp Condition Table. Crimp Condition Table is available from Part No. link.
(If you are using a cable that is not listed in Crimp Condition Table, please contact a Hirose sales representative.)

Bulk Contact, Applicable Tool: Manual Crimping Tool

Part No.	HRS No.	Applicable cable					Finish	Purchase Unit
		UL style	AWG	Wire Construction	Sectional area	Jacket diameter		
DF22-1416PCA	CL0680-1192-0-00	1430	16	26/0.254mm	1.32mm ²	2.6mm	Gold Plated	100pcs per bag
DF22A-1416PCA	CL0680-1193-0-00	1015	14	26/0.254mm	2.18mm ²	3.7mm		
			16	26/0.254mm	1.32mm ²	3.2mm		

Note 1: The conductor of applicable wire is tin plated annealed copper.

Note 2: For applicable cable other than those listed above, refer to Crimp Condition Table. Crimp Condition Table is available from Part No. link.
(If you are using a cable that is not listed in Crimp Condition Table, please contact a Hirose sales representative.)

Mated Dimensions

● Socket to Straight Header Connection

1 Pos.

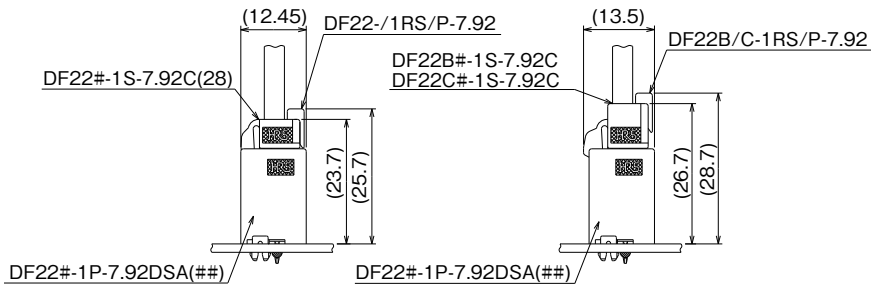

2 to 5 Pos.

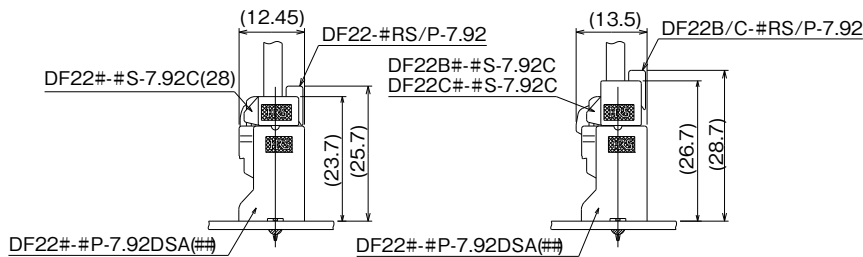

● Socket to Right Angle Header Connection

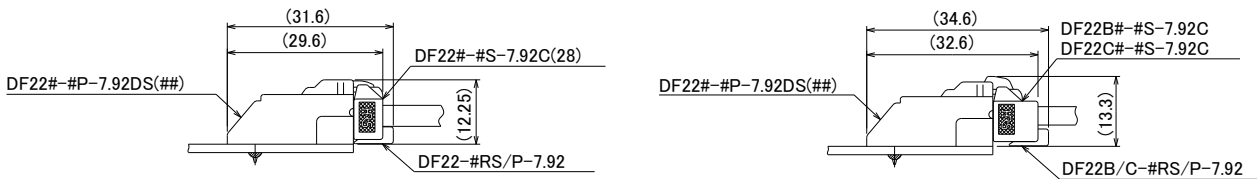

● Socket to In-line Plug (Panel lock type) Connection

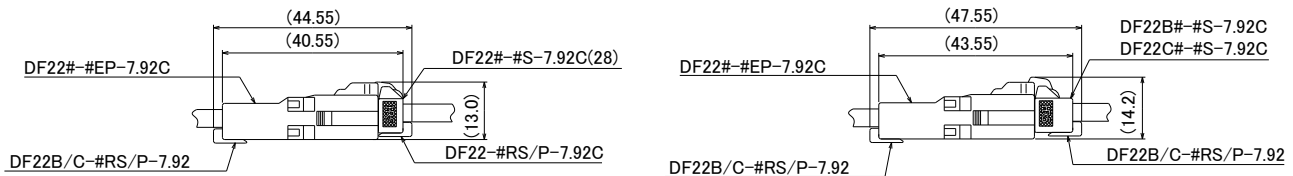

● Socket to In-line Plug Connection

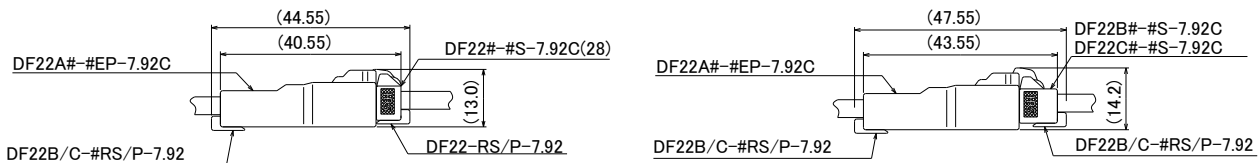

● In-line Double-row socket to In-line Double-row Plug (Panel lock type) Connection

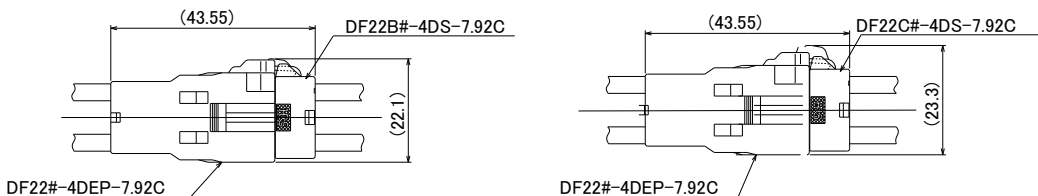

● In-line Double-row socket to In-line Double-row Plug Connection

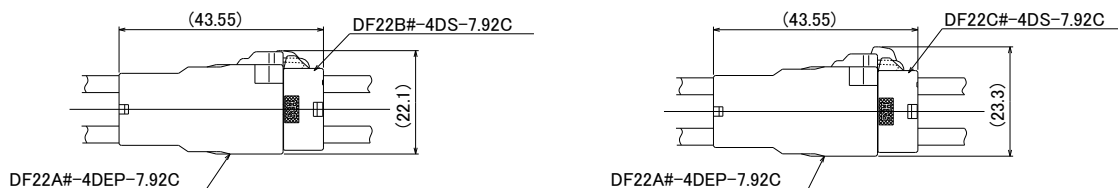

● Branch Connection

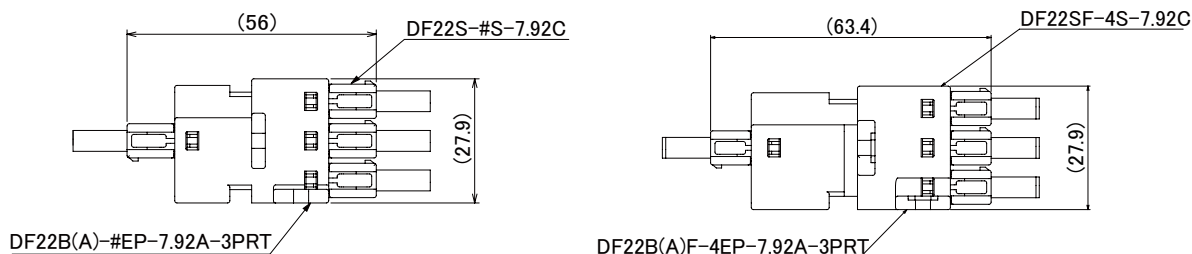

Tools

Type	Part No.	HRS No.	Applicable Wire (Note 7)	Applicable Contact (Note 6)
Hirose Press Unit	CM-105C	CL0901-0001-0-00	-	DF22/DF22A-1416SCFA/PCFA
Applicators Used in Hirose Press Unit	AP105-DF22-1416	CL0901-4576-7-00	UL1430	DF22-1416SCFA/PCFA
	AP105-DF22A-1416	CL0901-4578-2-00	UL1015	DF22A-1416SCFA/PCFA
Applicators Used in Press Units of Other Japanese Companies (Note 2)	AP109A-DF22-1416	CL0901-4579-5-00	UL1430	DF22-1416SCFA/PCFA
	AP109A-DF22A-1416	CL0901-4580-4-00	UL1015	DF22A-1416SCFA/PCFA
	AP109A-DF22A-1012	CL0901-4582-0-00	UL1015	DF22A-1012SCFA (Note 1)
Applicator Manufactured by Japan Automatic Machine (Note 3)	CHS893800H-UP	-	UL1430	DF22-1416SCFA/PCFA
	CHS893900H-UP	-	UL1015	DF22A-1416SCFA/PCFA
	QHS895800H-UP	-	UL1015	DF22A-1012SCFA (Note 1)
Crimping Tools	HT104/DF22-1416	CL0550-0285-0-00	16 AWG : UL1430	DF22-1416SCA/PCA
	HT104/DF22A-1416	CL0550-0286-2-00	16, 14 AWG : UL1015	DF22A-1416SCA/PCA
	HT103/DF22A-1012	CL0550-0288-8-00	10, 12 AWG : UL1015	DF22A-1012SCA

Note 1: When crimping DF22A-1012SCFA use a press of at least 3.5 tons.

Note 2: Applicators compatible with other Japanese companies (AP109A Applicator) cannot be used with the Hirose Press Unit CM-105C.

An attachment is required when using the applicator. Please contact the press unit manufacturer for inquiries on attachments.

Note 3: Please contact Japan Automatic Machine (J.A.M.) via their homepage regarding inquiries on the applicator or crimping defects. (URL: <http://www.jam-net.co.jp>)

Note 4: Problems caused by tools other than those specified are not covered by the warranty.

Note 5: Crimping should be carried out based on the "Crimping Quality Standards" and "Crimping Conditions Table."

Note 6: Applicable contacts are limited to those listed in the table.

Note 7: Applicable cables are limited to those listed in the table.

Contact Extraction

● Contact Extraction Tool

Flat-bladed screwdriver, 1.4mm blade width

● Intended Crimp Contacts

DF22-1416SC(F)A, DF22A-1416SC(F)A, DF22A-1012SC(F)A, DF22-1416PC(F)A, DF22A-1416PC(F)A

● Work Method

1. Refer to the drawing No. 1. Insert correct size screwdriver in the housing against the molded-in lance. Push down the lance as shown.
2. Assure that the lance is deflected to release the contact and pull out wire with the crimped contact.

(Housing Cross- Sectional Diagram)

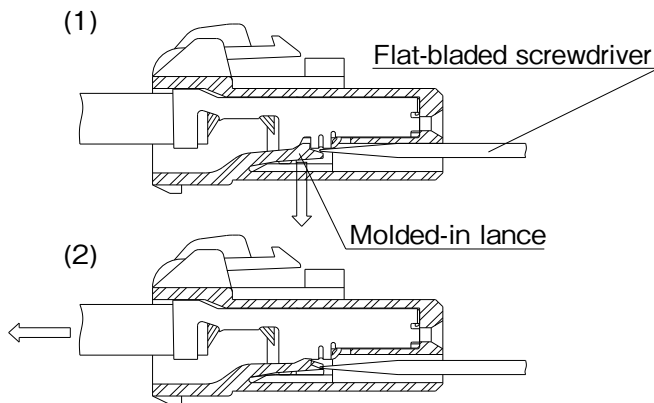

Note: Please do not reuse the repaired housing. Replace it to new one.

⚠ Caution There are parts on the crimp contact that can cause injuries, please use caution when unmating the contacts.

Precautions

1. Cleaning Condition	Refer to the "Product Guidelines (Board-to-Wire Connector Guidelines)"
2. Connection Condition	Refer to the "Product Guidelines (Board-to-Wire Connector Guidelines)"
3. Cautions	The color of the plastic molding may differ slightly depending on product lot and future storage conditions but this does not affect the product performance. Black spots may appear on the mold resin but this does not affect the product quality.
4. Precaution	Please refer to the materials listed below on our company website when handling this product. <ul style="list-style-type: none"> ■ Crimp Quality Standards ■ Harness Procedure Manual ■ Product Guidelines (Board-to-Wire Connector Guidelines)

Precautions When Using High-Current Connectors

1. If this product is used outside the specifications, evaluate it in the final set to confirm that there are no problems in use.

2. No outdoor use.

3. Notification for harness assembly

- 1) When inserting the crimping terminal to the crimping socket, please do not tilt the crimping terminal or twist the cable. Insertion at tilted angles or twisting the cable may cause deformation of the crimping terminal or crimping socket.
- 2) After inserting the crimping terminal to the crimping socket, please make sure that the lance has been hooked with pulling the cable lightly. When checking the hook, please avoid bending the cable for preventing terminal drop-off.

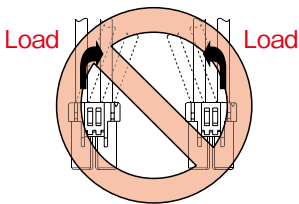

3) Bundle cables/ Cabtyre Cables

Recommend bundle and strip position of cables are 100mm or more.

Bundling close to the connectors may cause terminal drop-off, breaking cables and unstable connection.

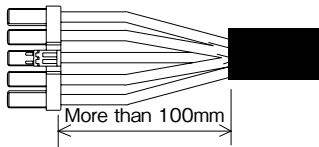

4. Notification for Insertion Extraction

⚠ Caution

- 1) Please insert/extract the crimping socket straight to the mating connector. Insertion/extraction at tilted angles applies load concentration to the connector end and may cause deformation (at connection area, socket and header case, etc). There is firing risk using this kind of deformed connector.

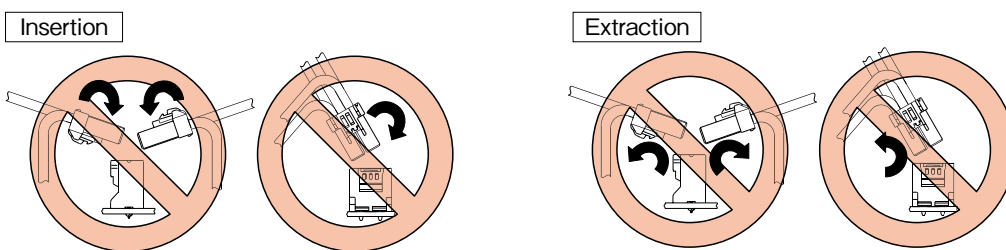

- 2) When it is hard to extract, please lightly insert the connector beforehand and then pull it with releasing the lock. Forced extraction has a risk of connector breakage.

5. Notification of wiring

⚠ Caution

- 1) When using a thick cable, short cable length and bending close to the connector end, these load concentration may cause deformation. Please note that there is firing risk using deformed connector. When installing, please refrain from stress concentration such as cable bending close to the connector end or cable twisting.

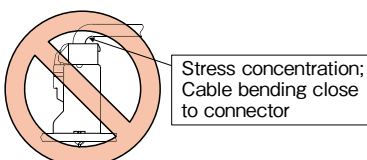

Current Ratings

The current rating listed in the catalog indicates the allowable current per contact. However, in applications requiring current transmission through all the contacts, about one-third of the listed rating should be applied. When the current rating for the connector is 3A, and the allowable current of the conductor being used is 1A, then rating of 1A will be used for the entire assembly.

The connectors should not be mating / unmating when the electrical current is being applied. Hot swap should not be performed.

While Taking into Consideration

Specifications mentioned in this catalog are reference values.

When considering to order or use this product, please review the Drawing and Product Specifications sheets.

Use an appropriate cable when using the connector in combination with cables.

If considering usage of a non-specified cable, please contact your sales representative.

If assembly process is done by jigs & tools which are not identified by Hirose, the warranty of the product may be affected.

If considering usage for below mentioned applications, please contact your sales representative.

In cases where the application will demand a high level of reliability, such as automotive, medical instruments, public infrastructure, aerospace/defense etc. Hirose must review before assurance of reliability can be given.