

LOC	DIST	REV	DATE	BY	APPD
-	-	1	SEE SHEET 1	-	-

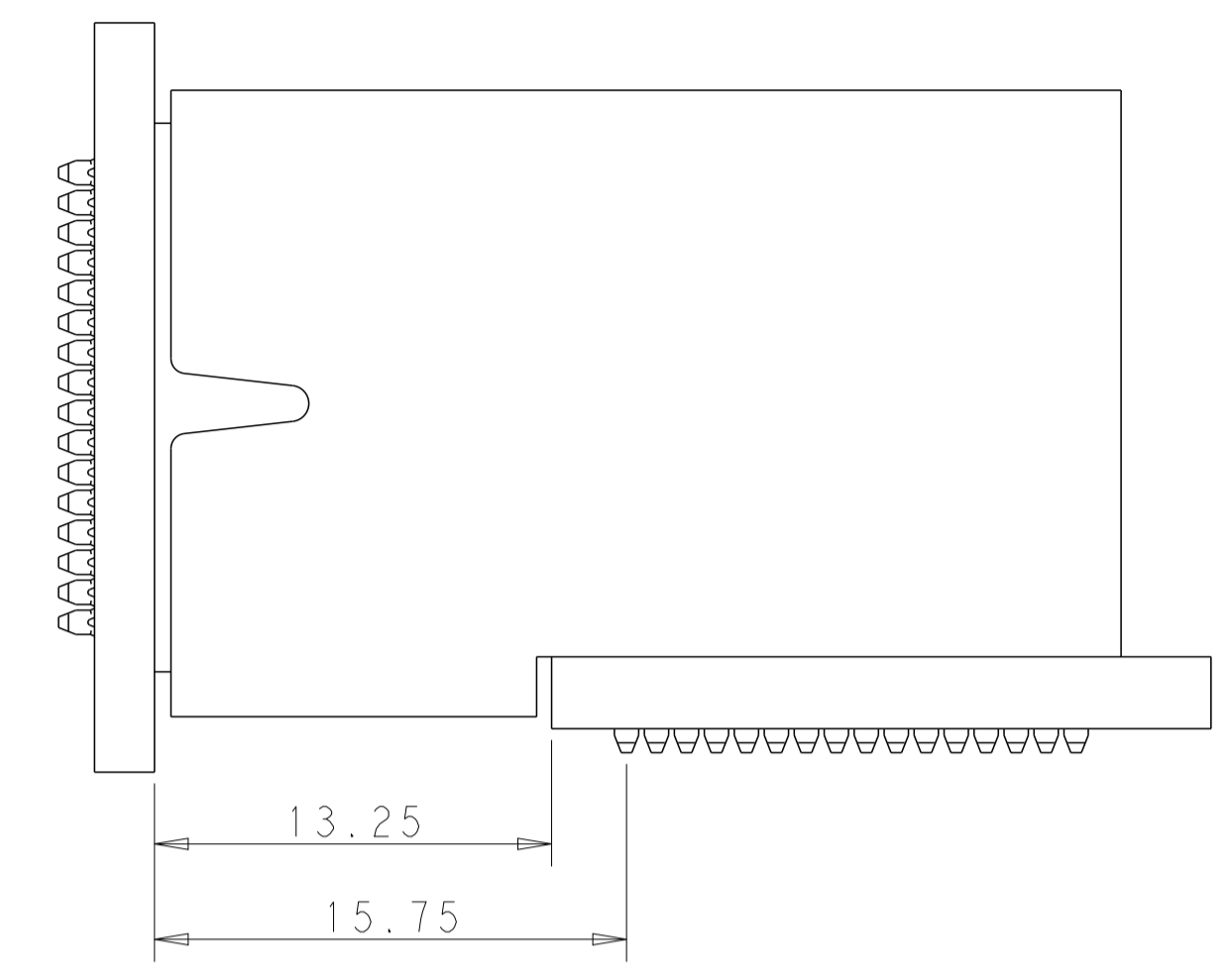

THE DISTANCE IS 0.05 MM MATING FACE FROM R/A PLUG TO VERTICAL REC.

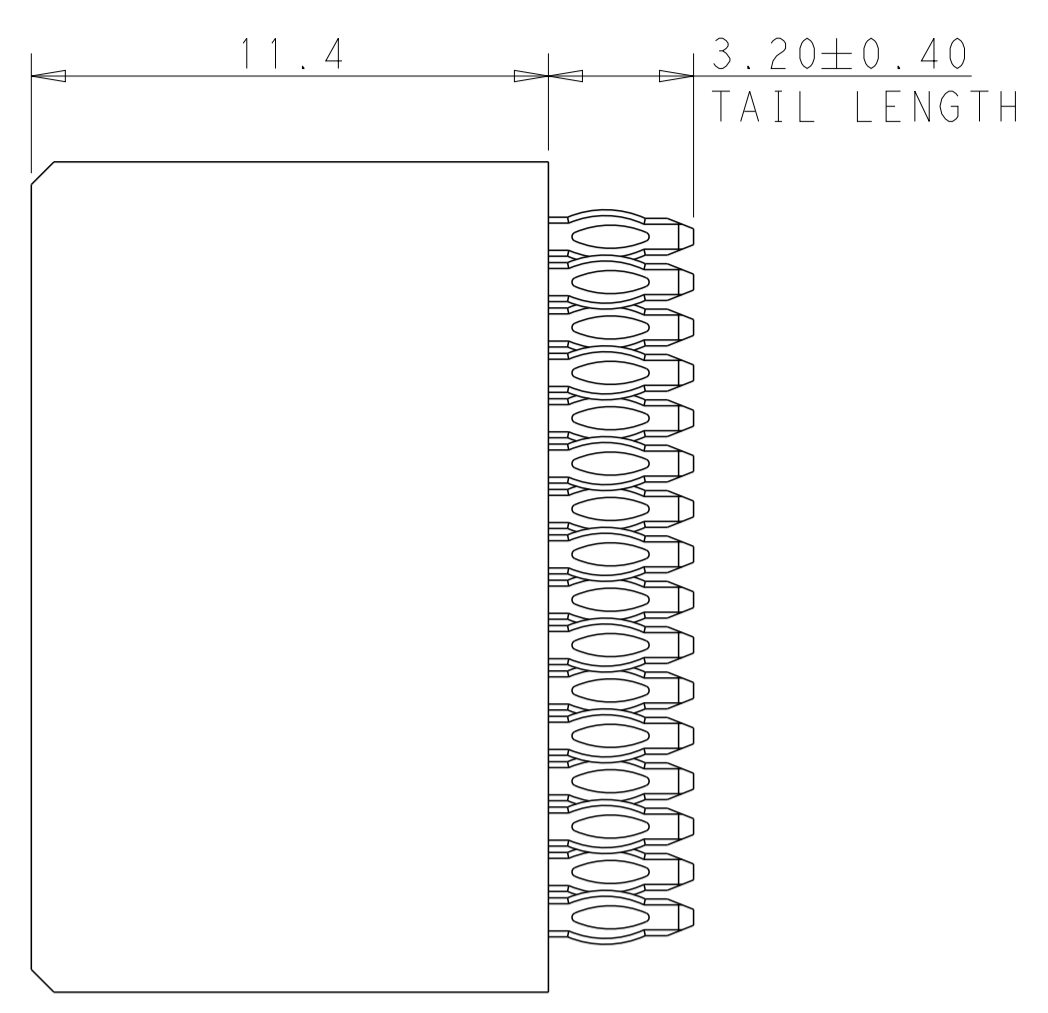
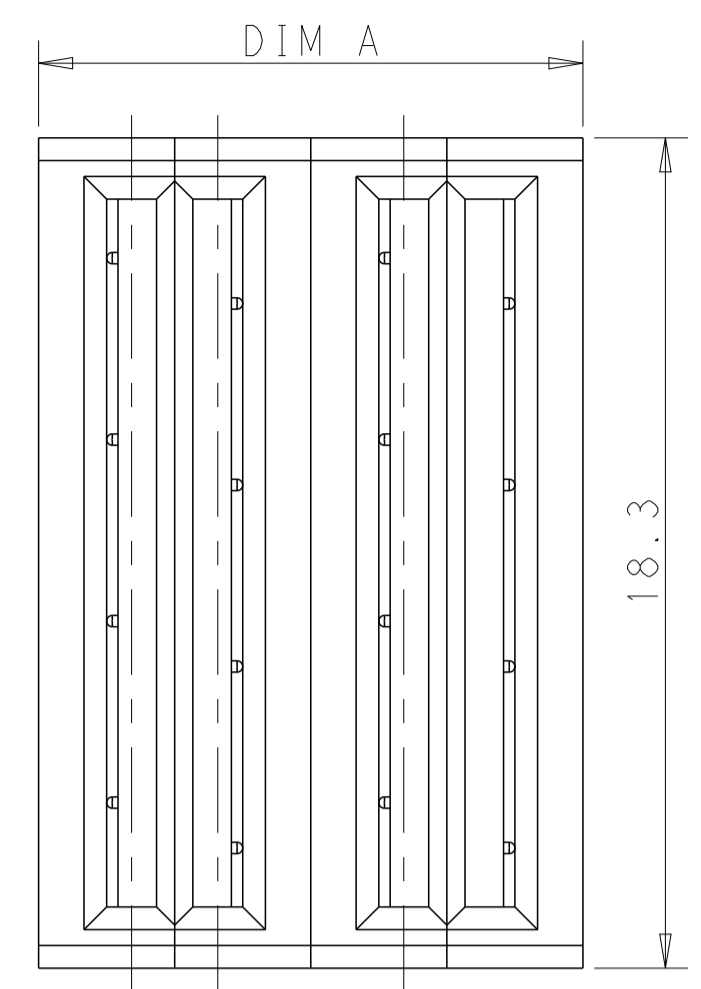
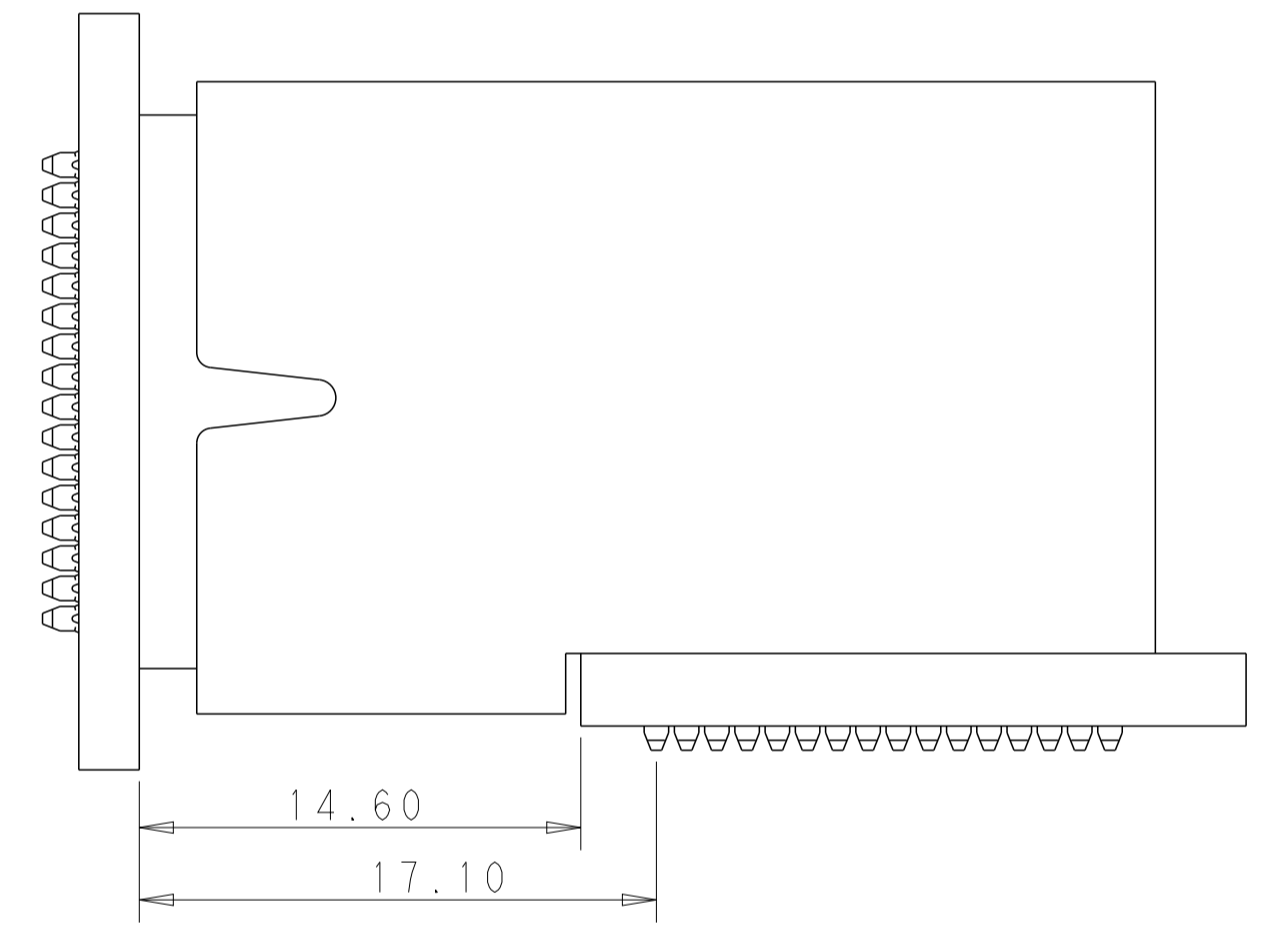
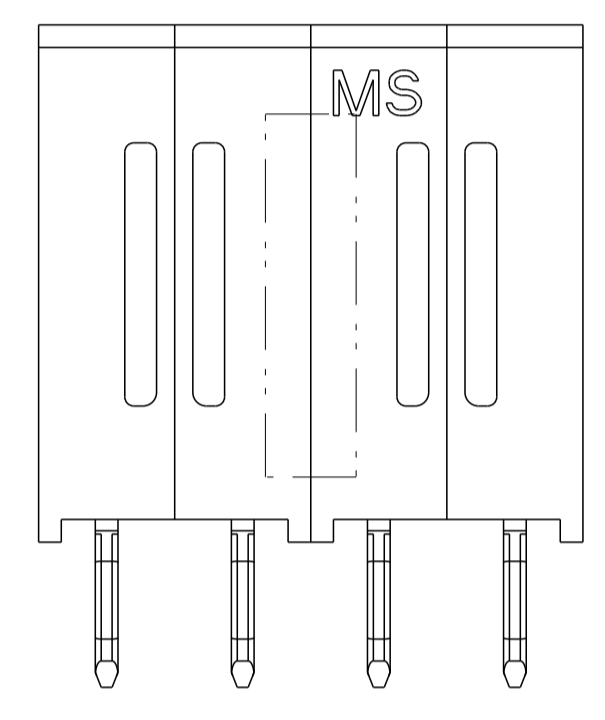

THE DISTANCE IS 1.4 MM MATING FACE FROM R/A PLUG TO VERTICAL REC.
2204443-1/1-2204423-5

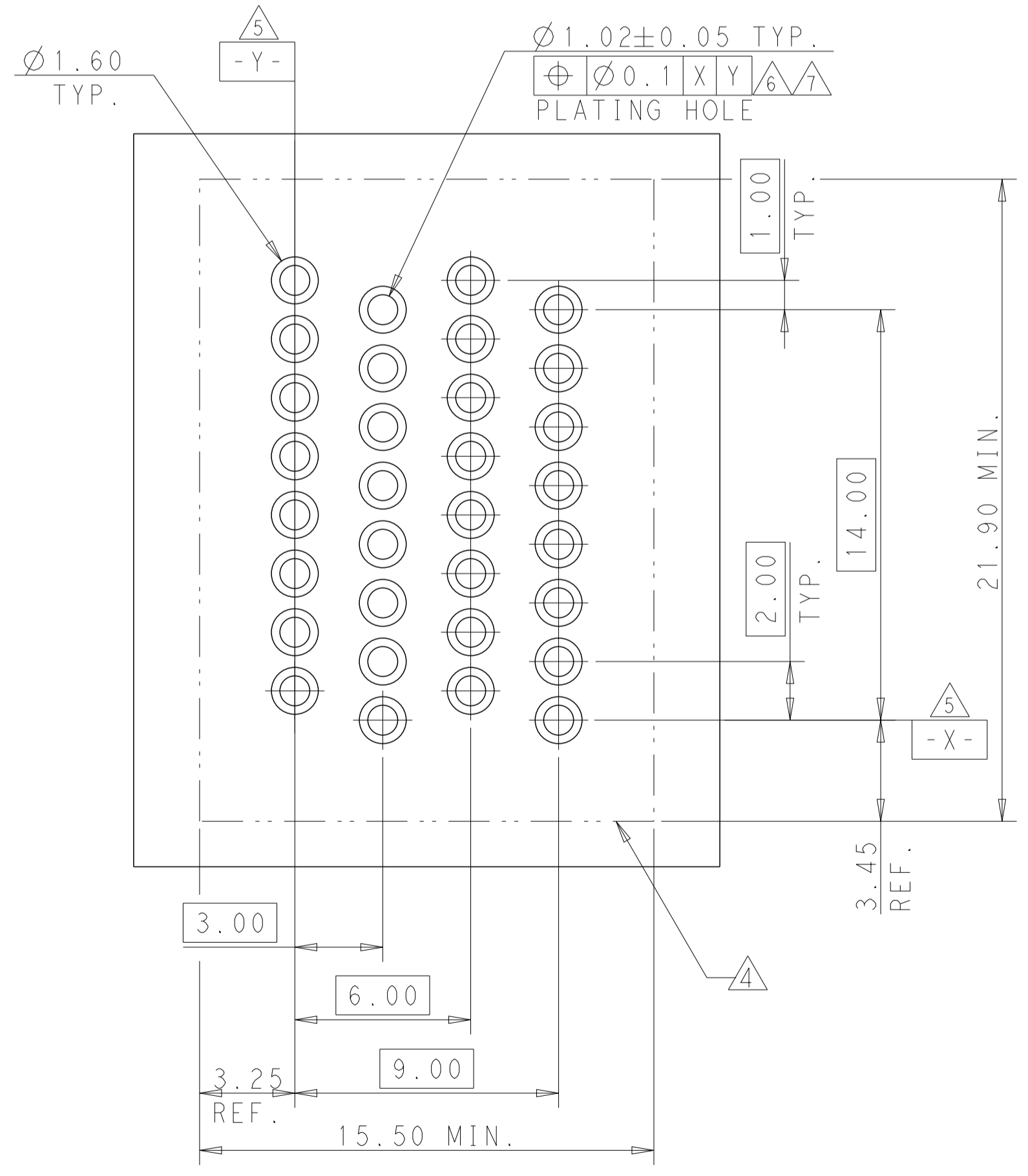

PART NUMBER	POWER			
	M4	M3	M2	M1
2204423-5	MM	MM	MN	MN
4MP				

POWER CONTACT MFBL UNMATING 1.4MM	PA
POWER CONTACT STANDARD UNMATING 1.4MM	PB
MIDDLE POWER CONTACT MFBL	MM
MIDDLE POWER CONTACT STANDARD	MN
POWER CONTACT MFBL	PM
POWER CONTACT STANDARD	PN
DESCRIPTION	CODE

THIS DRAWING IS A CONTROLLED DOCUMENT.

THOMAS ZHAO 28JUN2013
SUNY ZHAO 28JUN2013

TE Connectivity

VERTICAL RECEPTACLE PRESS FIT
MULTI-BEAM HD W/GUIDELESS
Customer Drawing

SCALE 5:1 SHEET 2 OF 6 REV A10

LOC		DIST		REVISIONS			
P	LTN	DESCRIPTION	DATE	DMN	APVD		
-	-	SEE SHEET 1	-	-	-	-	-

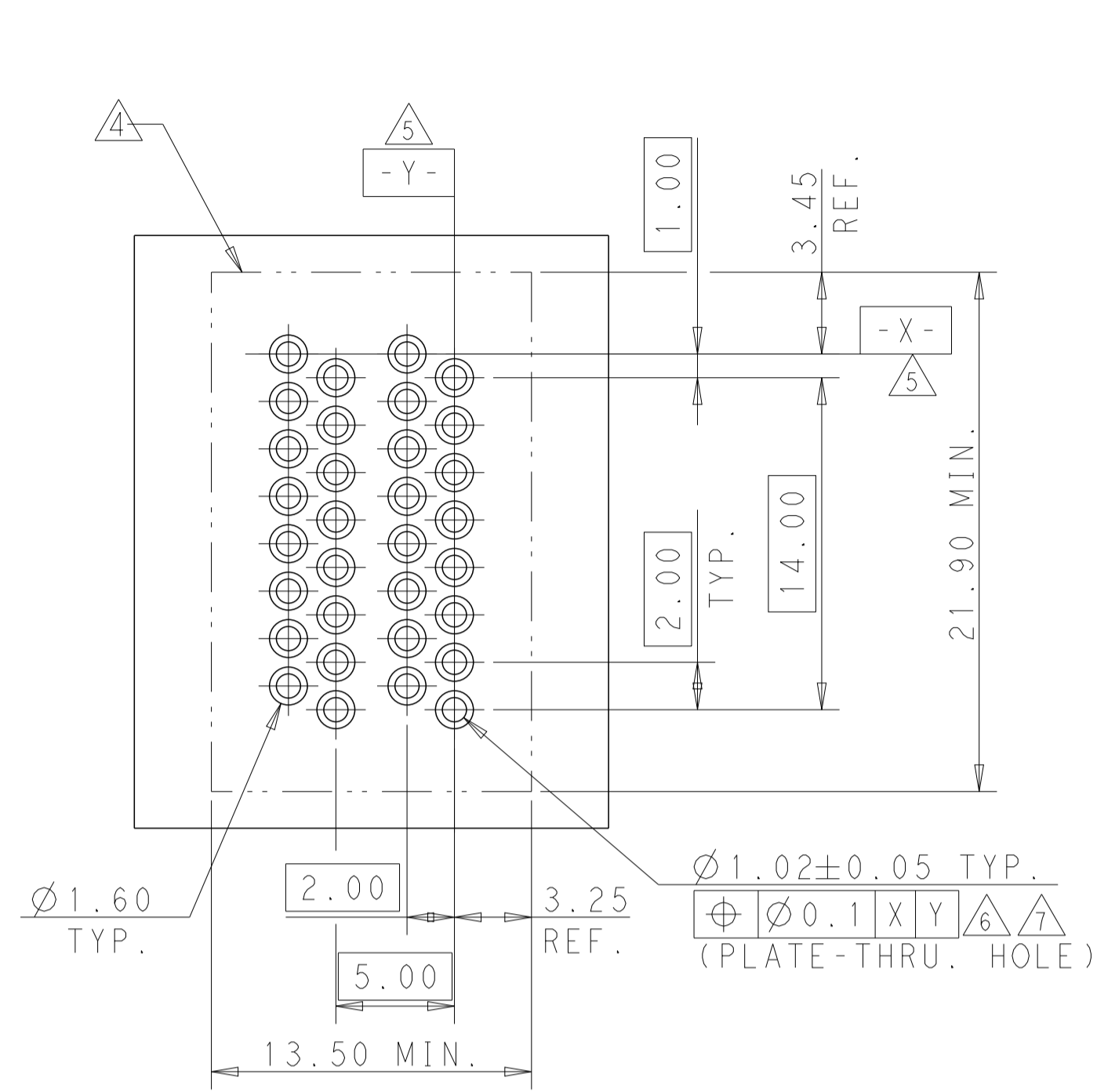

PCB LAYOUT PART NUMBER: 2204423-2

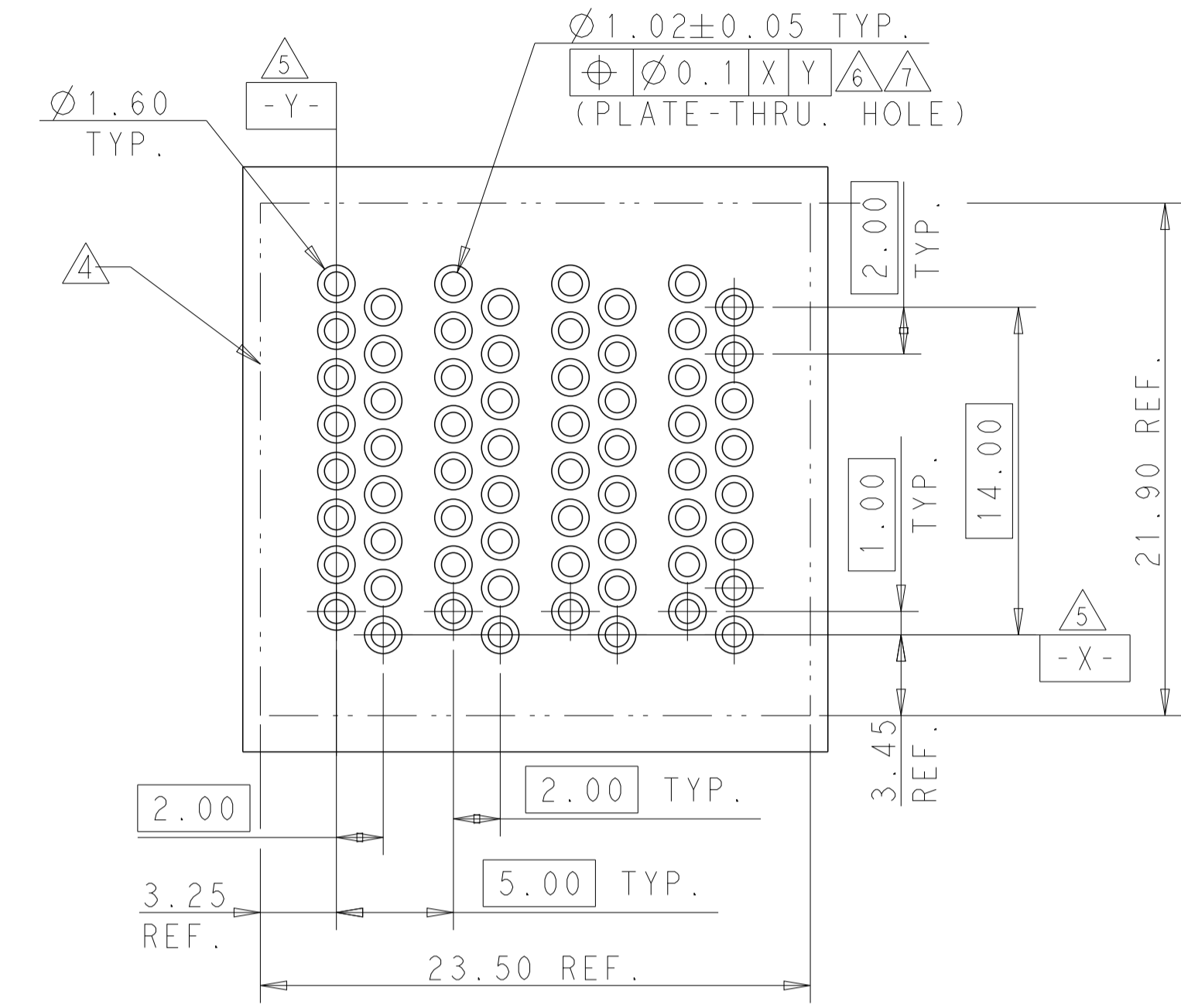

PCB LAYOUT PART NUMBER: 2204423-3/1-2204423-1

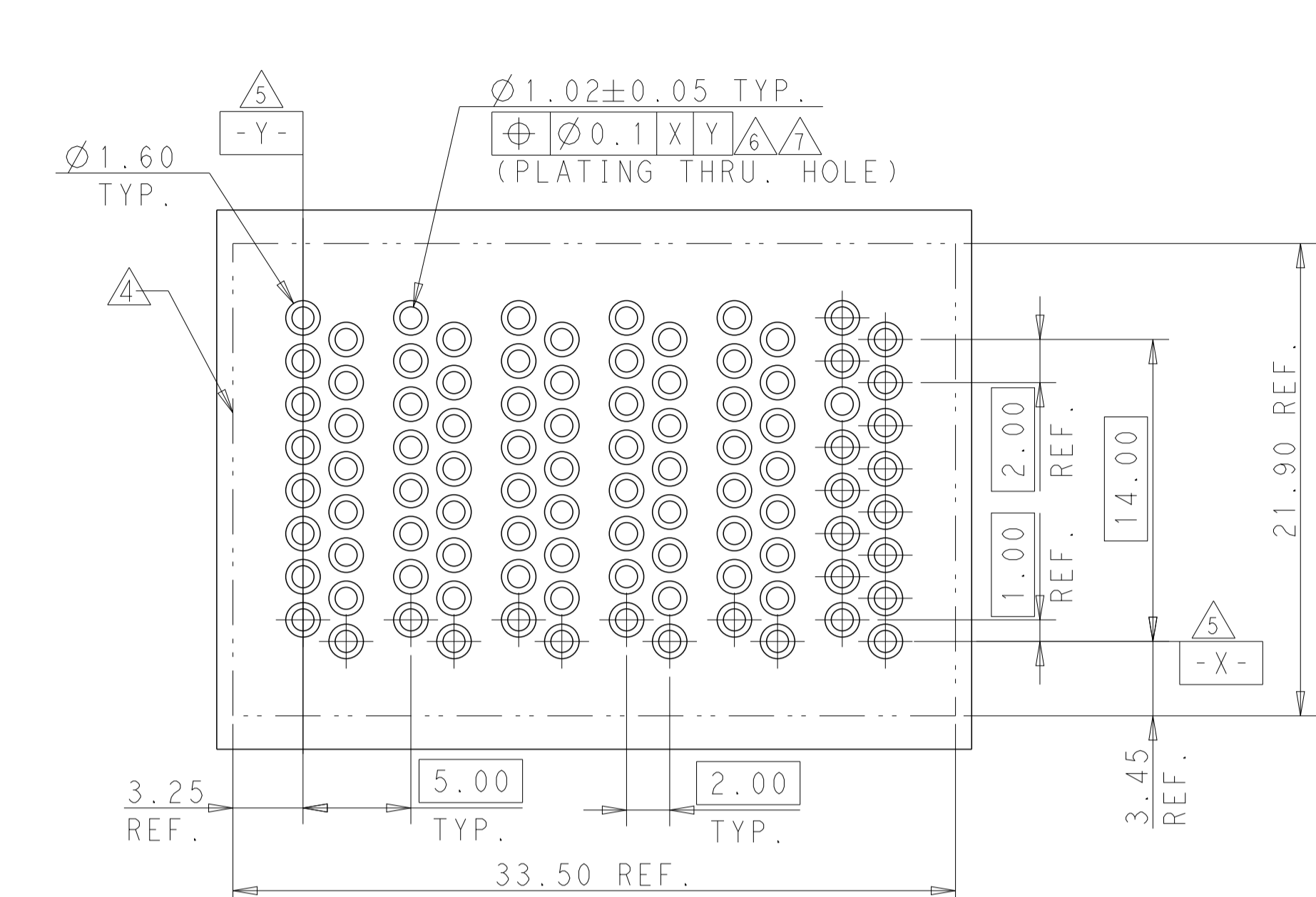

PCB LAYOUT PART NUMBER: 2204423-4

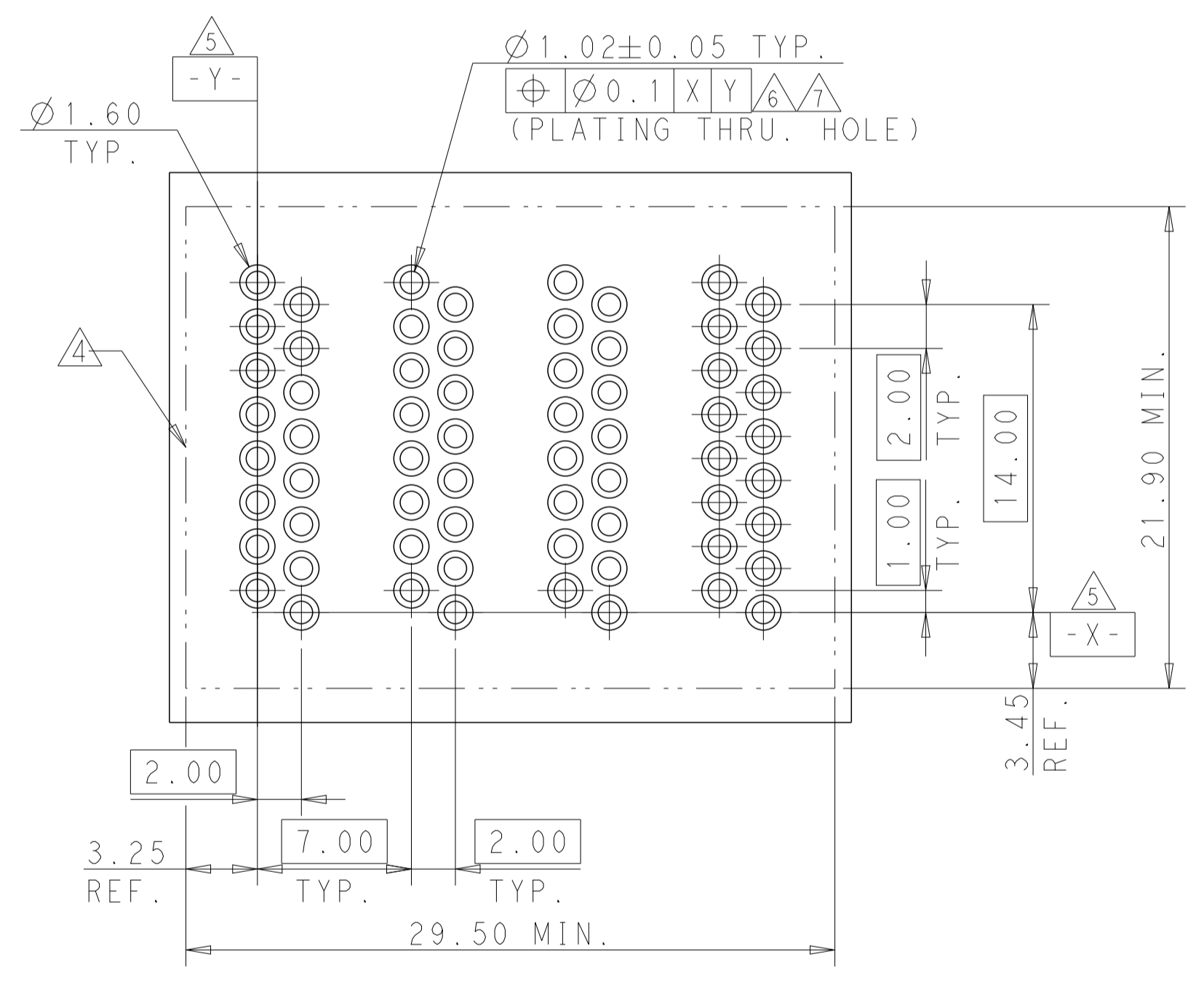

PCB LAYOUT PART NUMBER: 2204423-8

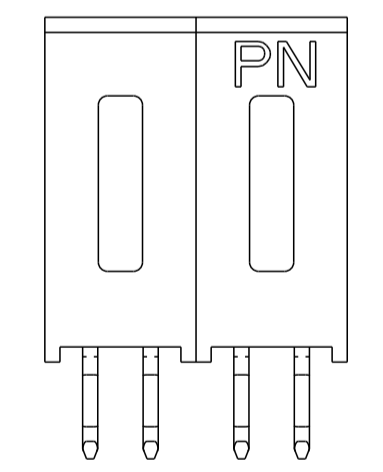
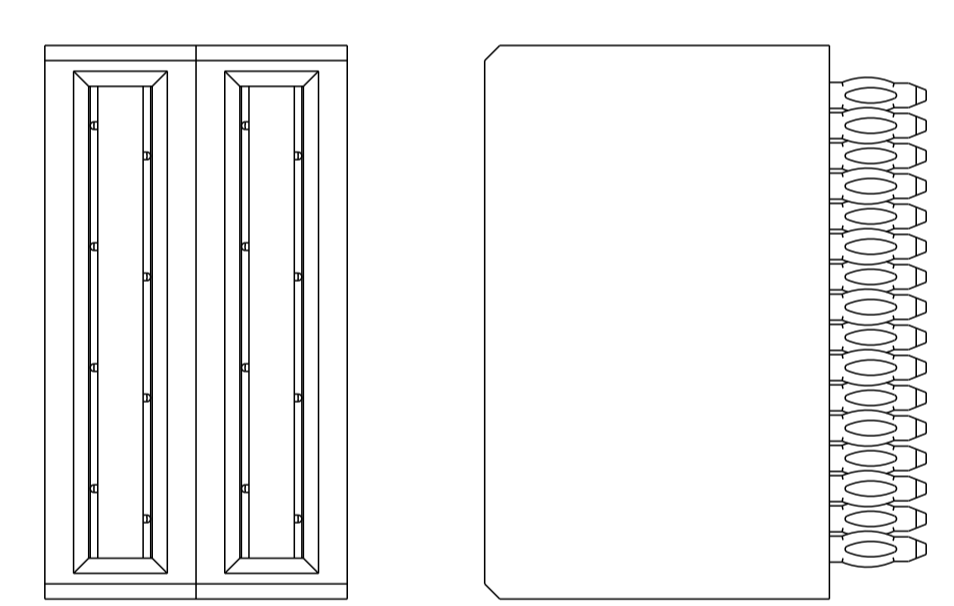

PART NUMBER: 2204423-2

PART NUMBER	POWER	
	P2	P1
2204423-2	PM	PN
2P		

PART NUMBER	POWER			
	P4	P3	P2	P1
2204423-3	PM	PM	PM	PM
4P				

PART NUMBER	POWER					
	P6	P5	P4	P3	P2	P1
2204423-4	PM	PM	PM	PM	PM	PM
6P						

PART NUMBER	POWER			
	P4	P3	P2	P1
2204423-8	PM	PM	PM	PM
4HVP				

THIS DRAWING IS A CONTROLLED DOCUMENT. DWN THOMAS_ZHAO 28JUN2013
 CHK SUNY_ZHAO 28JUN2013
 APVD SUNY_ZHAO 28JUN2013

STE TE Connectivity

NAME: VERTICAL RECEPTACLE PRESS FIT MUTIL-BEAM HD W/GUIDELESS Customer Drawing

SIZE: A1 CAGE CODE: - DRAWING NO: C=2204423 RESTRICTED TO: -

MATERIAL: FINISH: CUSTOMER DRAWING WEIGHT: SCALE: 5:1 SHEET 3 OF 6 REV: A10

LOC		DIST		REVISIONS			
P	LTN	DESCRIPTION	DATE	DWN	APVD		
-	-	SEE SHEET 1	-	-	-		

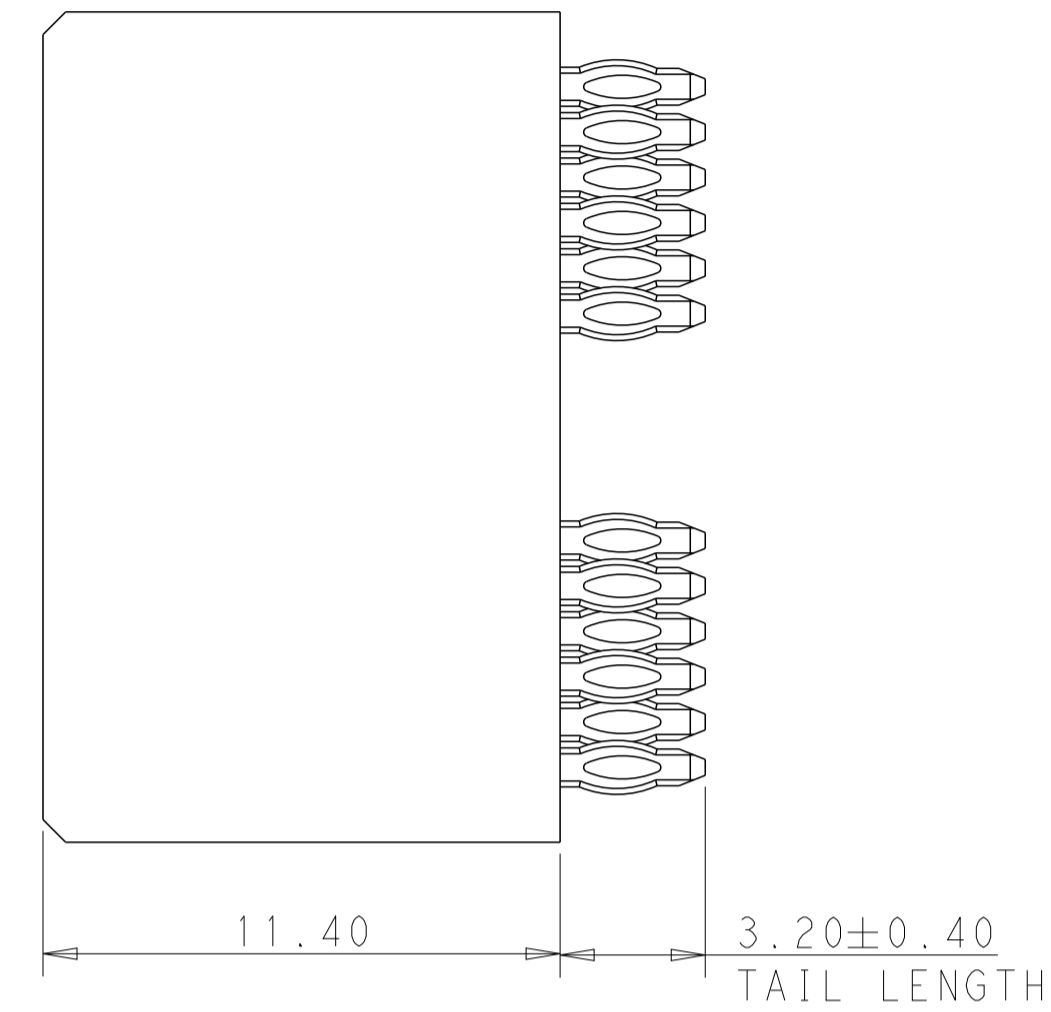
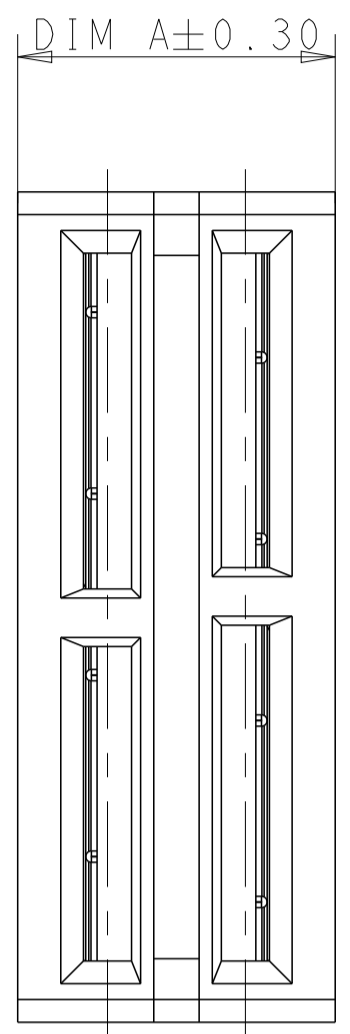

PART NUMBER	POWER	
	LP2	LP1
2204423-6	LM1	LM1
	LM2	LM2
4 LP		

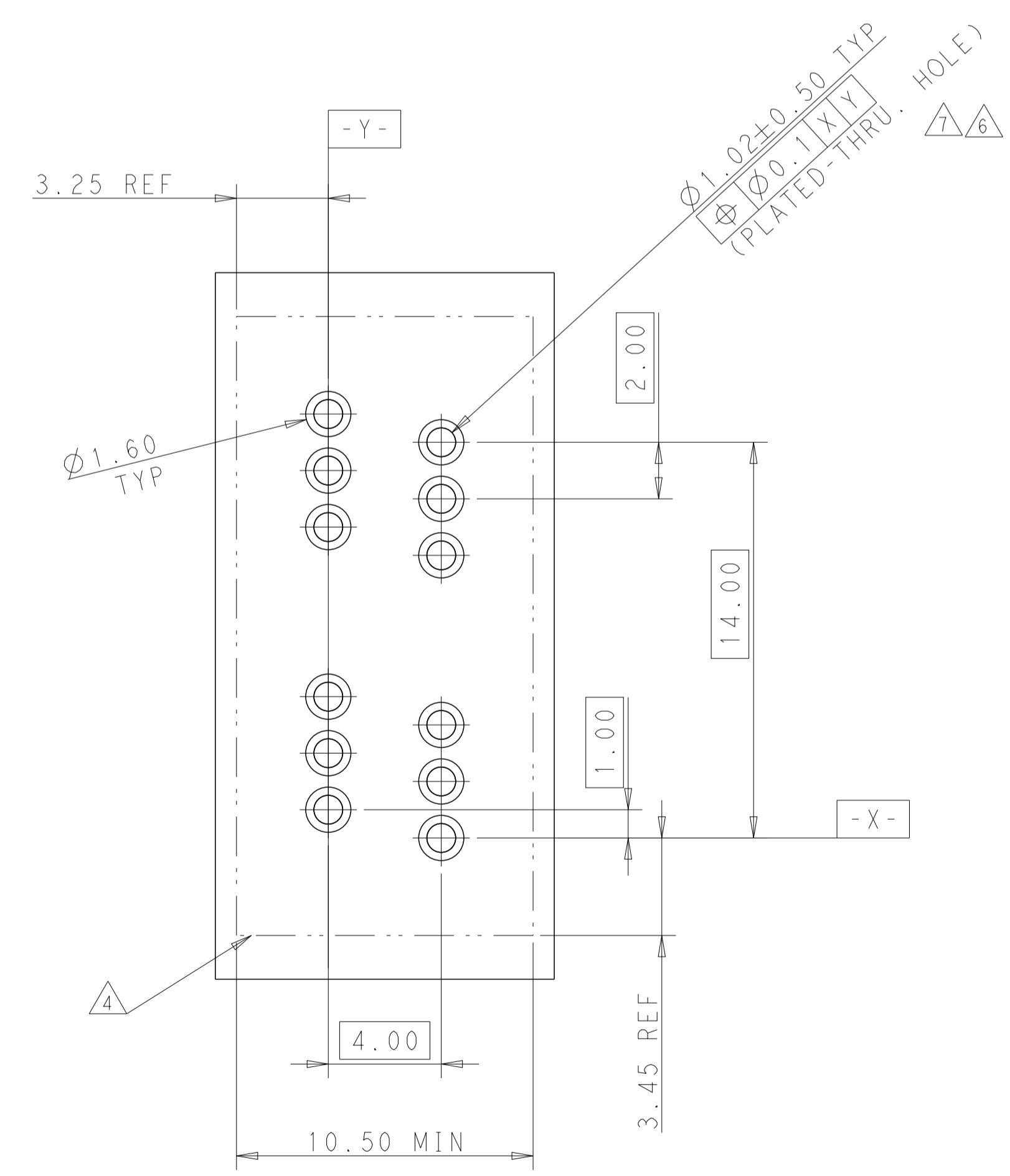
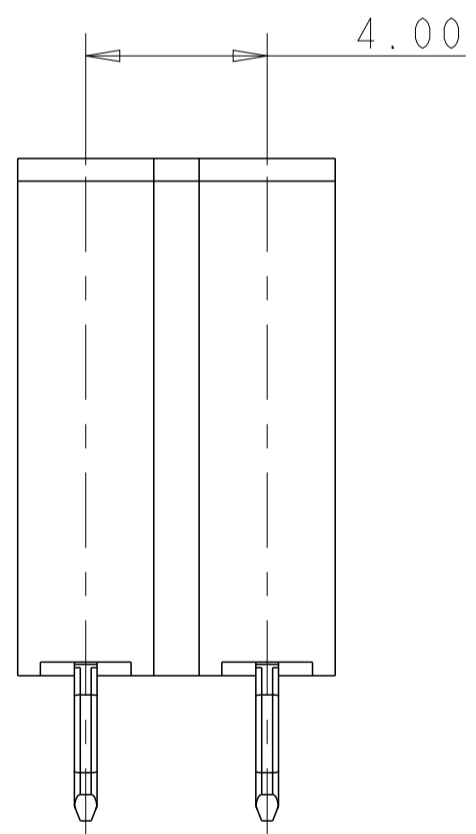

LP TOP CONTACT MFBL PRESS FIT	LM1
LP BOTTOM CONTACT MFBL PRESS FIT	LM2
DESCRIPTION	IDENTIFIER

THIS DRAWING IS A CONTROLLED DOCUMENT.

DIMENSIONS:	TOLERANCES UNLESS OTHERWISE SPECIFIED:	DWN THOMAS ZHAO 28JUN2013	CHK SUNY ZHAO 28JUN2013	APVD SUNY ZHAO 28JUN2013	NAME
mm	0 PLC ±0.4 1 PLC ±0.4 2 PLC ±0.25 3 PLC ±0.15 4 PLC ±0.15	SUNY ZHAO 28JUN2013			PRODUCT SPEC
		SUNY ZHAO 28JUN2013			APPLICATION SPEC
		SUNY ZHAO 28JUN2013			SIZE CAGE CODE DRAWING NO
		SUNY ZHAO 28JUN2013			RESTRICTED TO
		SUNY ZHAO 28JUN2013			SCALE 5:1 SHEET 4 OF 6 REV A10
		SUNY ZHAO 28JUN2013			CUSTOMER DRAWING

MATERIAL: FINISH:

WEIGHT: -

DESCRIPTION: VERTICAL RECEPTACLE PRESS FIT MUTIL-BEAM HD W/GUIDELESS Customer Drawing

SIZE: A1 CAGE CODE: - DRAWING NO: C=2204423

SCALE: 5:1 SHEET: 4 OF 6 REV: A10

LOC	DIST	REVISIONS					
		P	LTH	DESCRIPTION	DATE	DWN	APVD
-	-	-	-	SEE SHEET 1	-	-	-

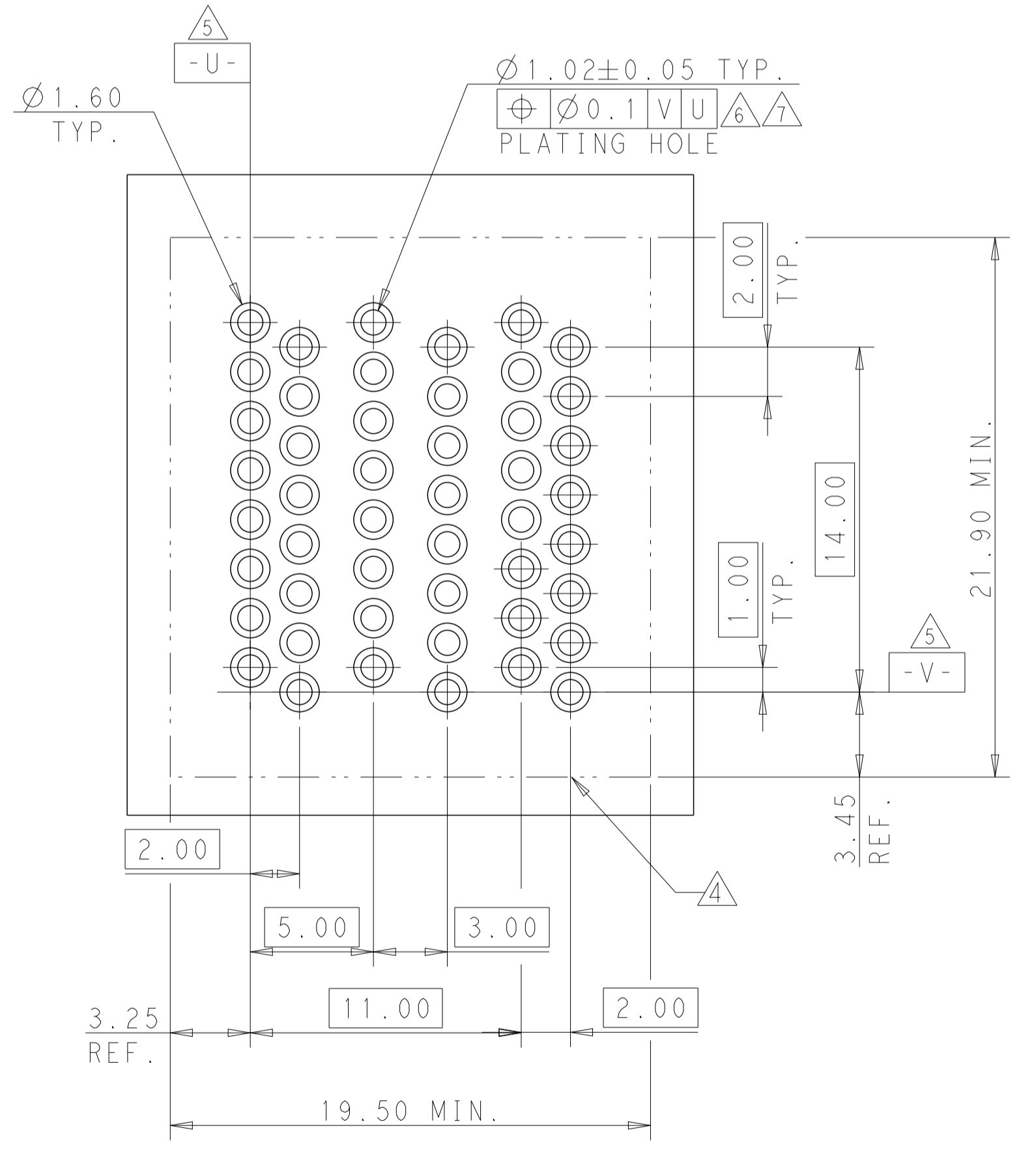
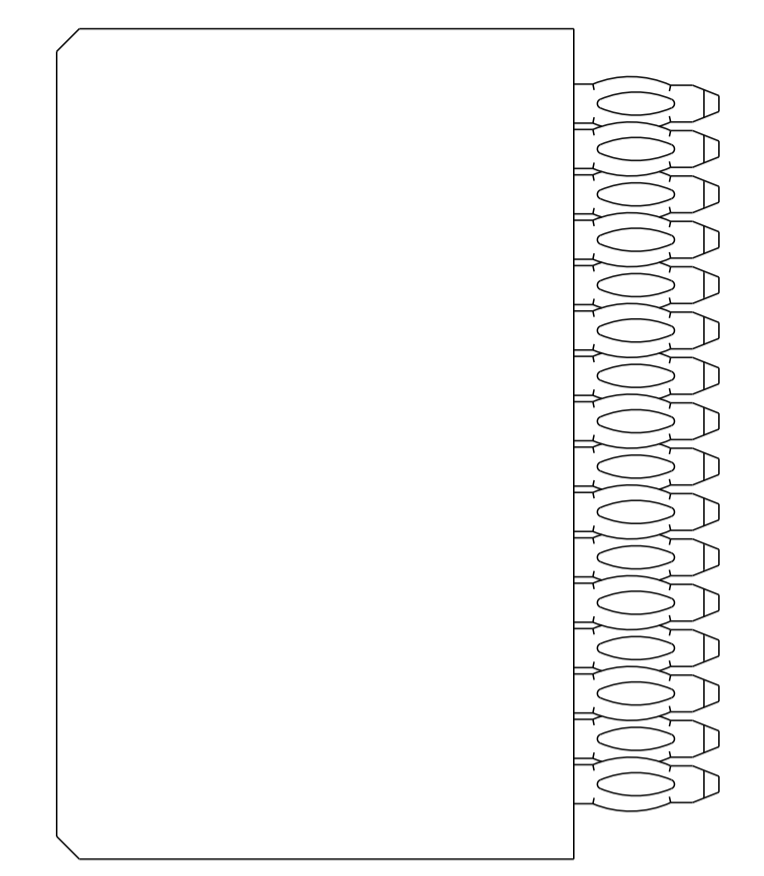
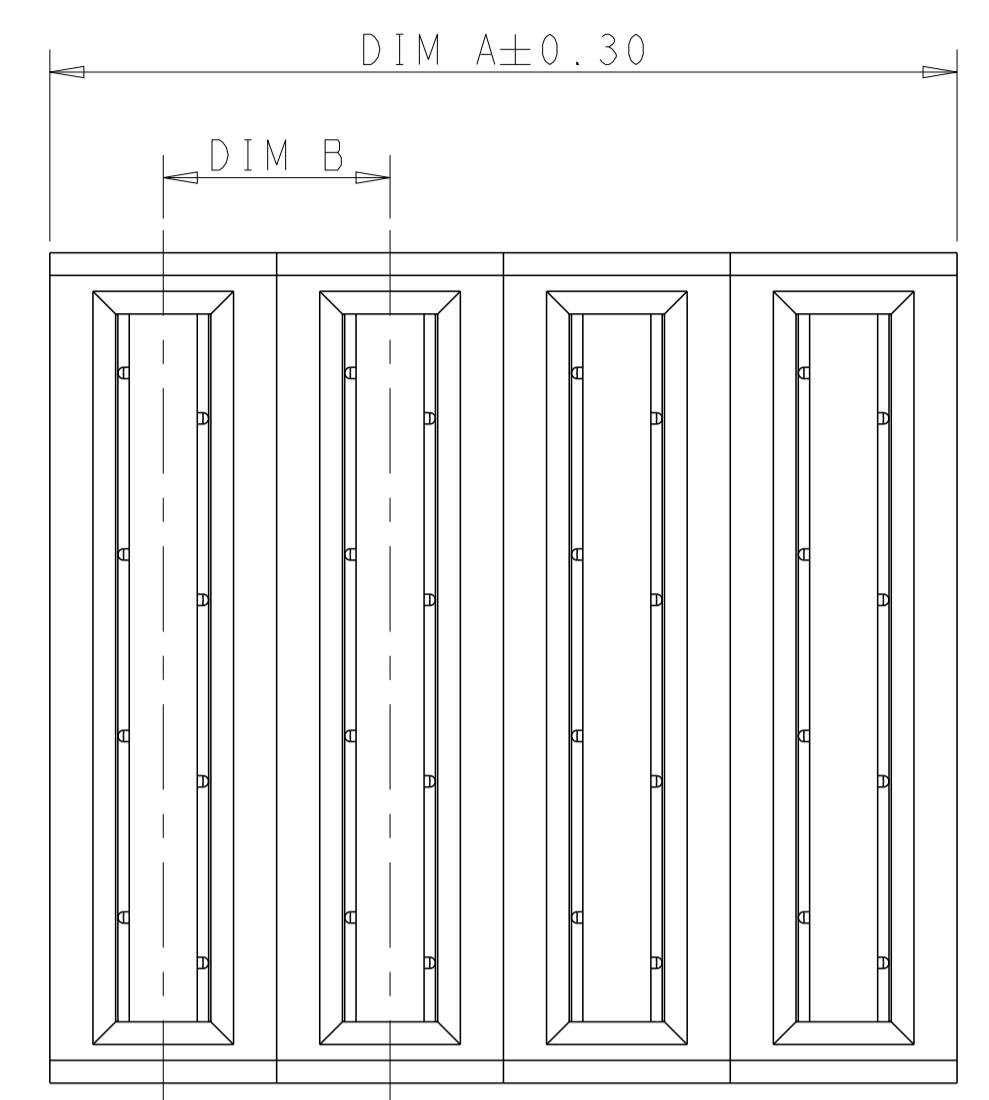
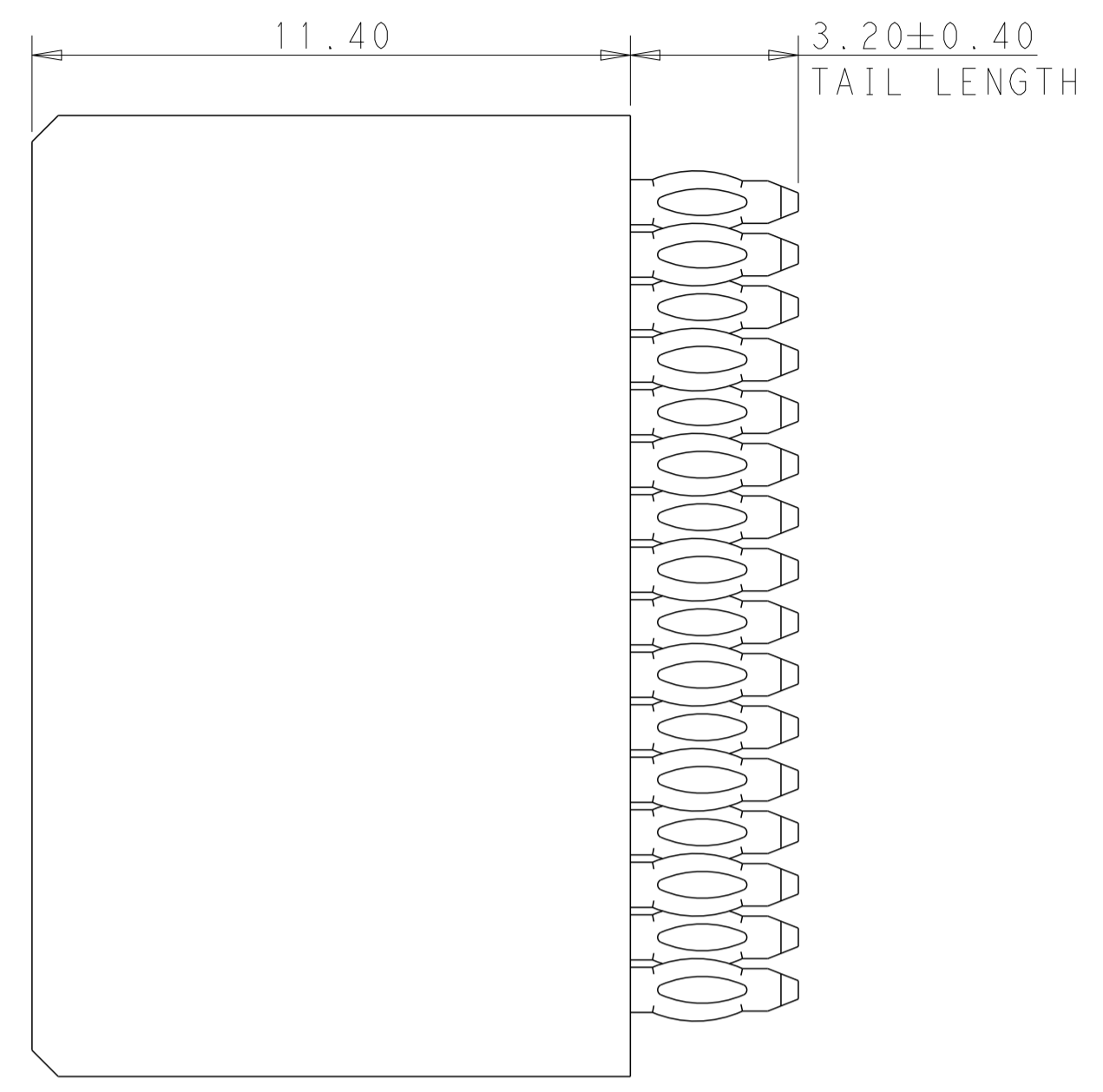
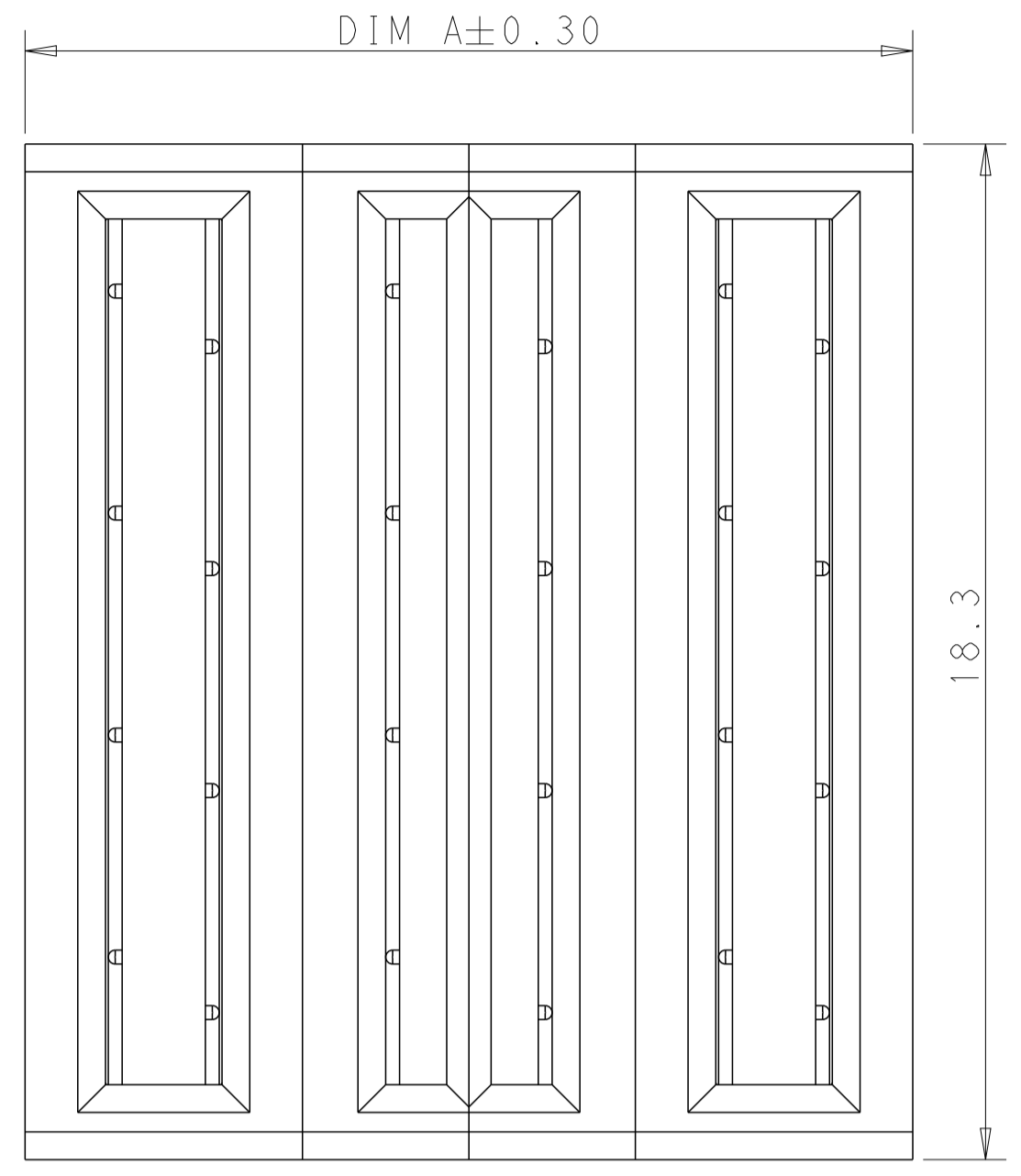

PART NUMBER	POWER			
	P2	M2	M1	P1
2204423-7	PM	MM	MM	PM
IP+2MP+IP				

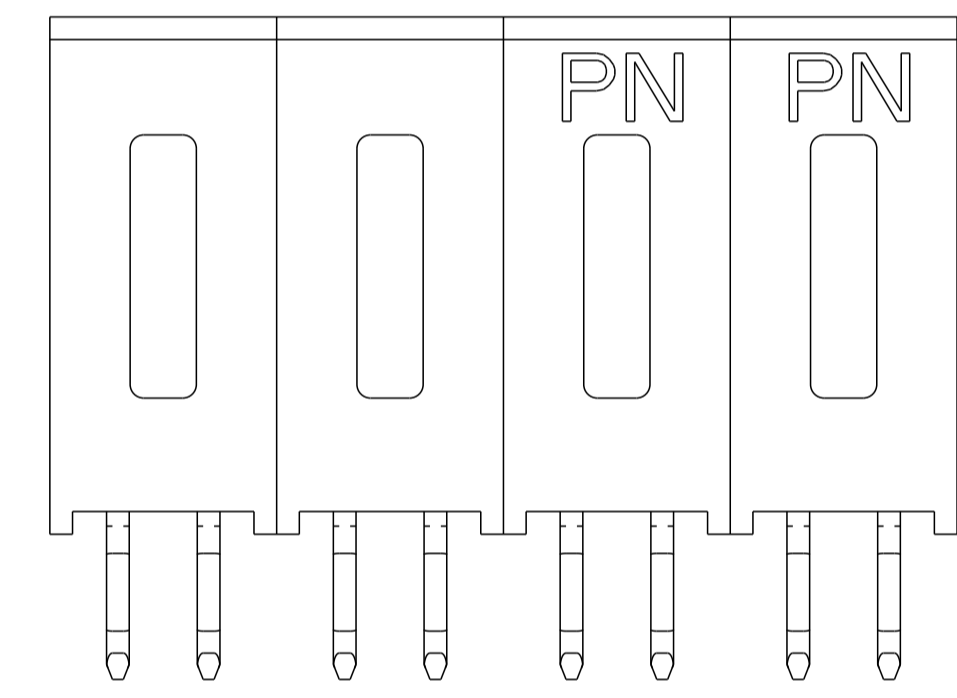

PART NUMBER: 1-2204423-1
PCB LAYOUT REFER: 2204423-3

PART NUMBER	POWER			
	P4	P3	P2	P1
1-2204423-1	PM	PM	PN	PN
4P				

PCB LAYOUT PART NUMBER: 2204423-7

THIS DRAWING IS A CONTROLLED DOCUMENT.		DWN THOMAS_ZHAO 28JUN2013	TE Connectivity
DIMENSIONS: mm		CHK SUNY_ZHAO 28JUN2013	
TOLERANCES UNLESS OTHERWISE SPECIFIED:		APVD SUNY_ZHAO 28JUN2013	NAME
0 PLC ±0.4		PRODUCT SPEC	VERTICAL RECEPTACLE PRESS FIT
1 PLC ±0.4		APPLICATION SPEC	MUTIL-BEAM HD W/GUIDELESS
2 PLC ±0.75		WEIGHT	Customer Drawing
3 PLC ±1.15		SIZE	A1
4 PLC ±1.5		CAGE CODE	-
ANGLES ±°		DRAWING NO	C=2204423
MATERIAL	FINISH	RESTRICTED TO	-
		CUSTOMER DRAWING	SCALE 5:1 SHEET 5 OF 6 REV A10

REVISONS		DATE	DWN	APVD
P	LTM			
-	-	SEE SHEET 1	-	-

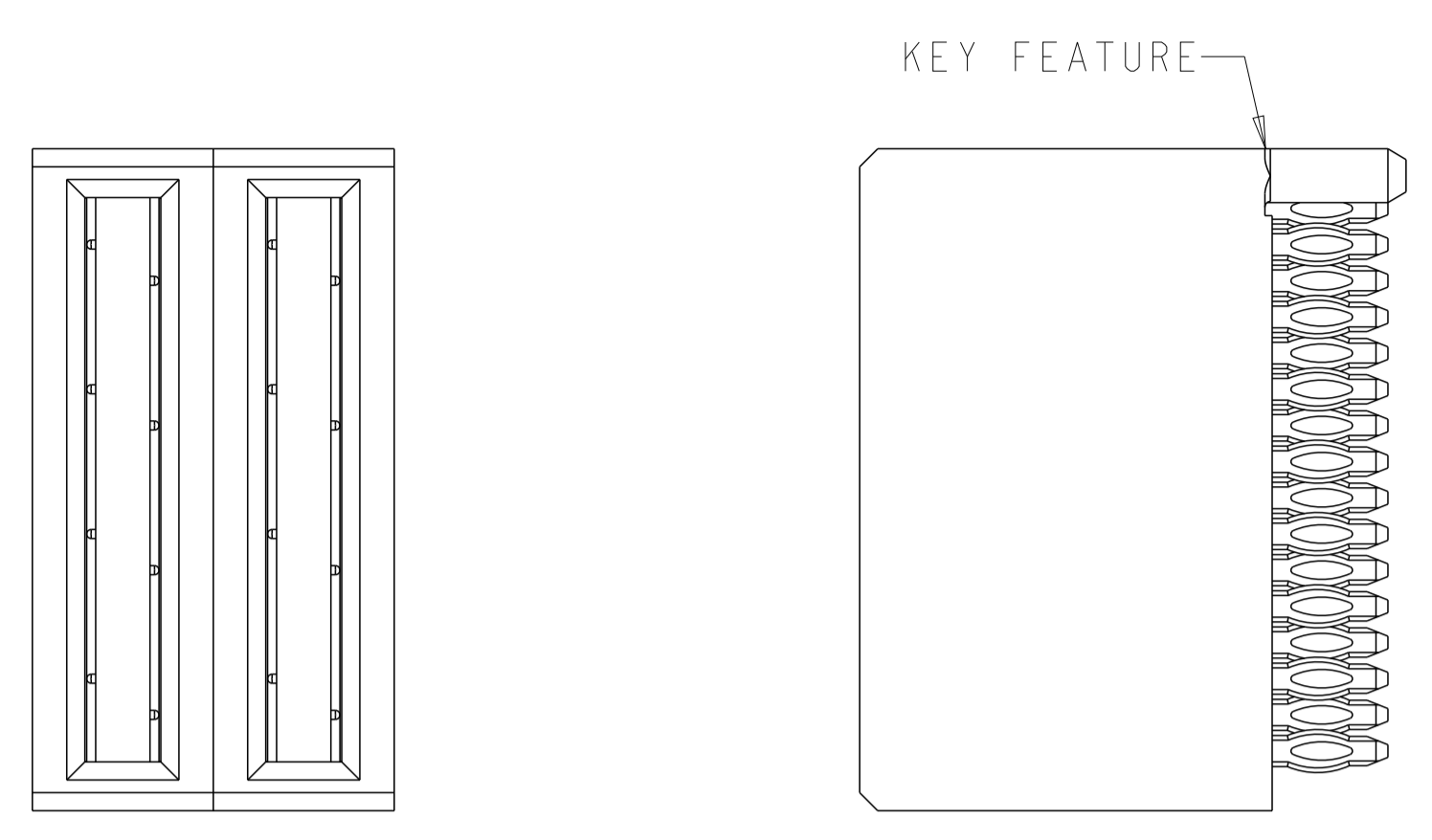

PART NUMBER	POWER	
	P2	P1
1-2204423-2	PM	PN
2P		

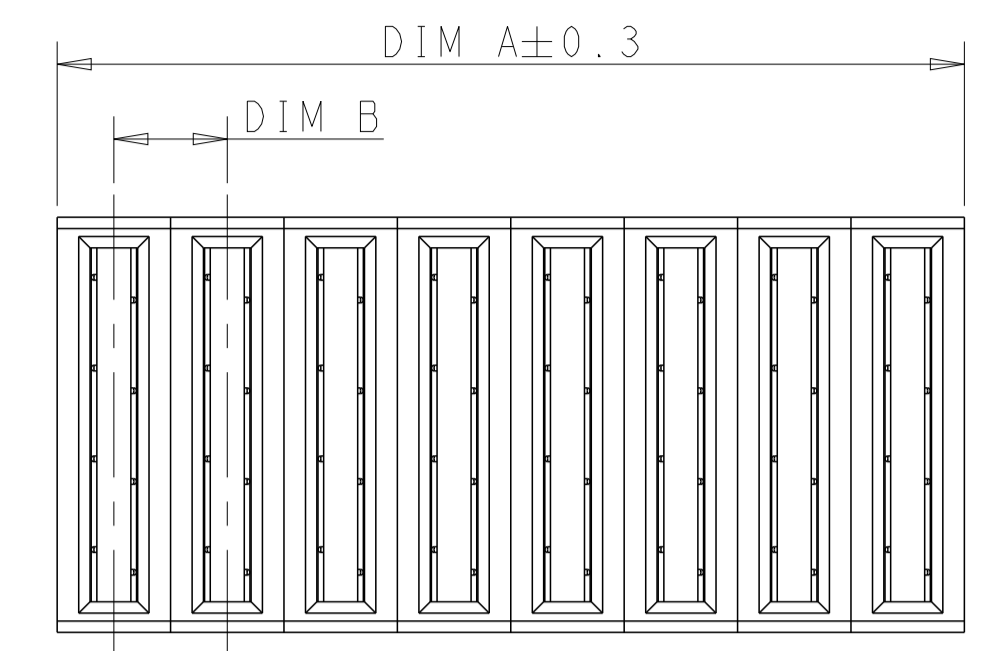
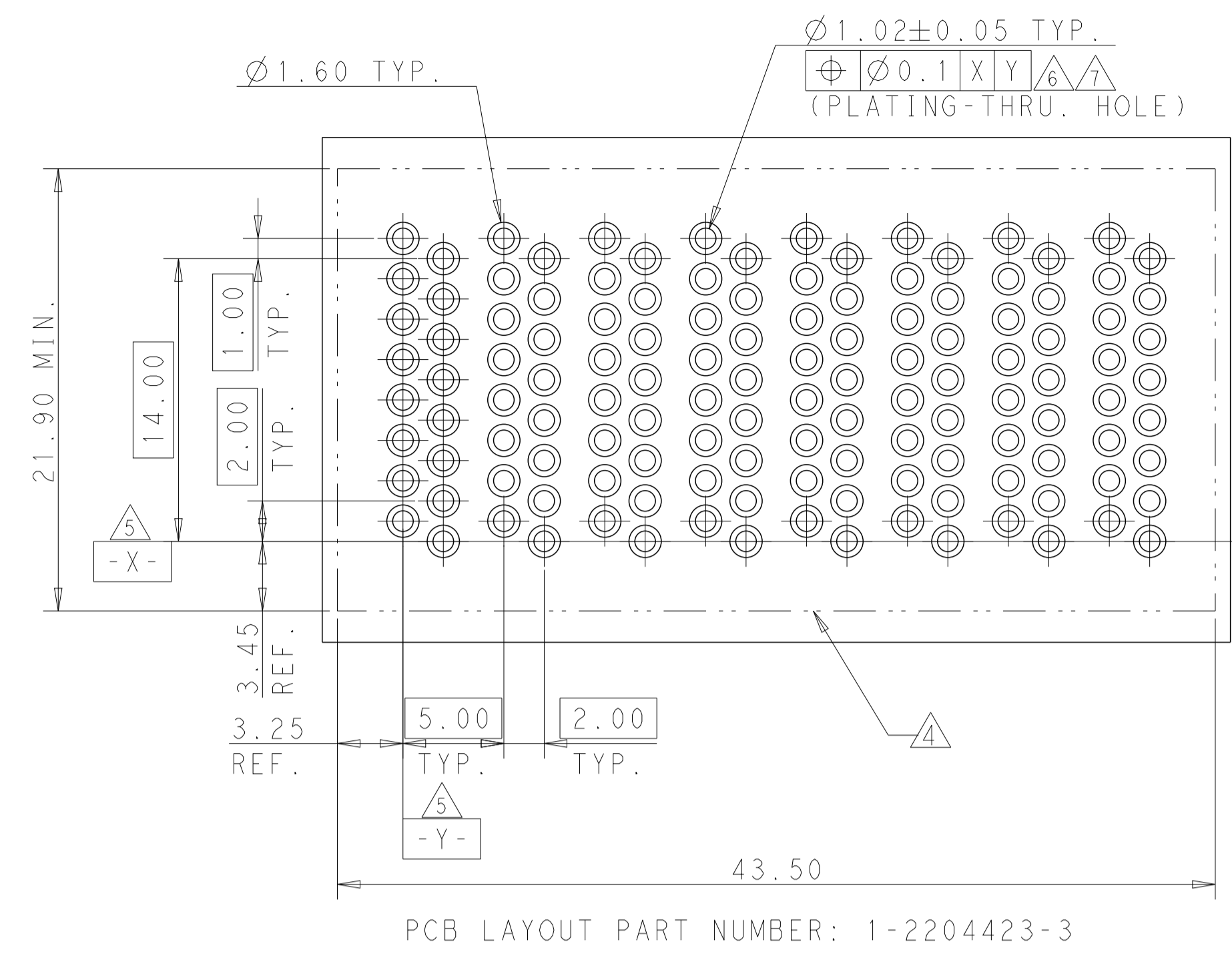
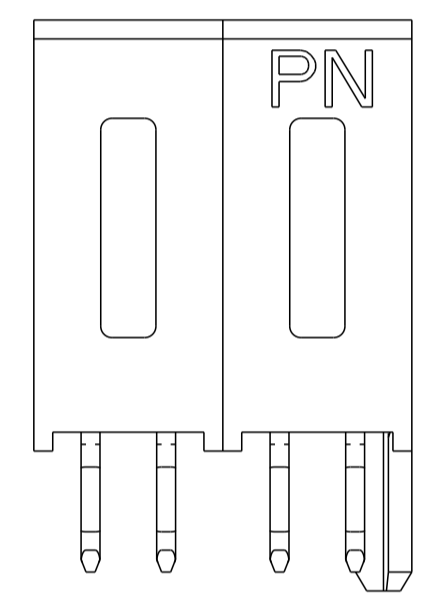

PART NUMBER	POWER							
	P8	P7	P6	P5	P4	P3	P2	P1
1-2204423-3	PM	PM	PM	PM	PM	PM	PM	PM
8P								

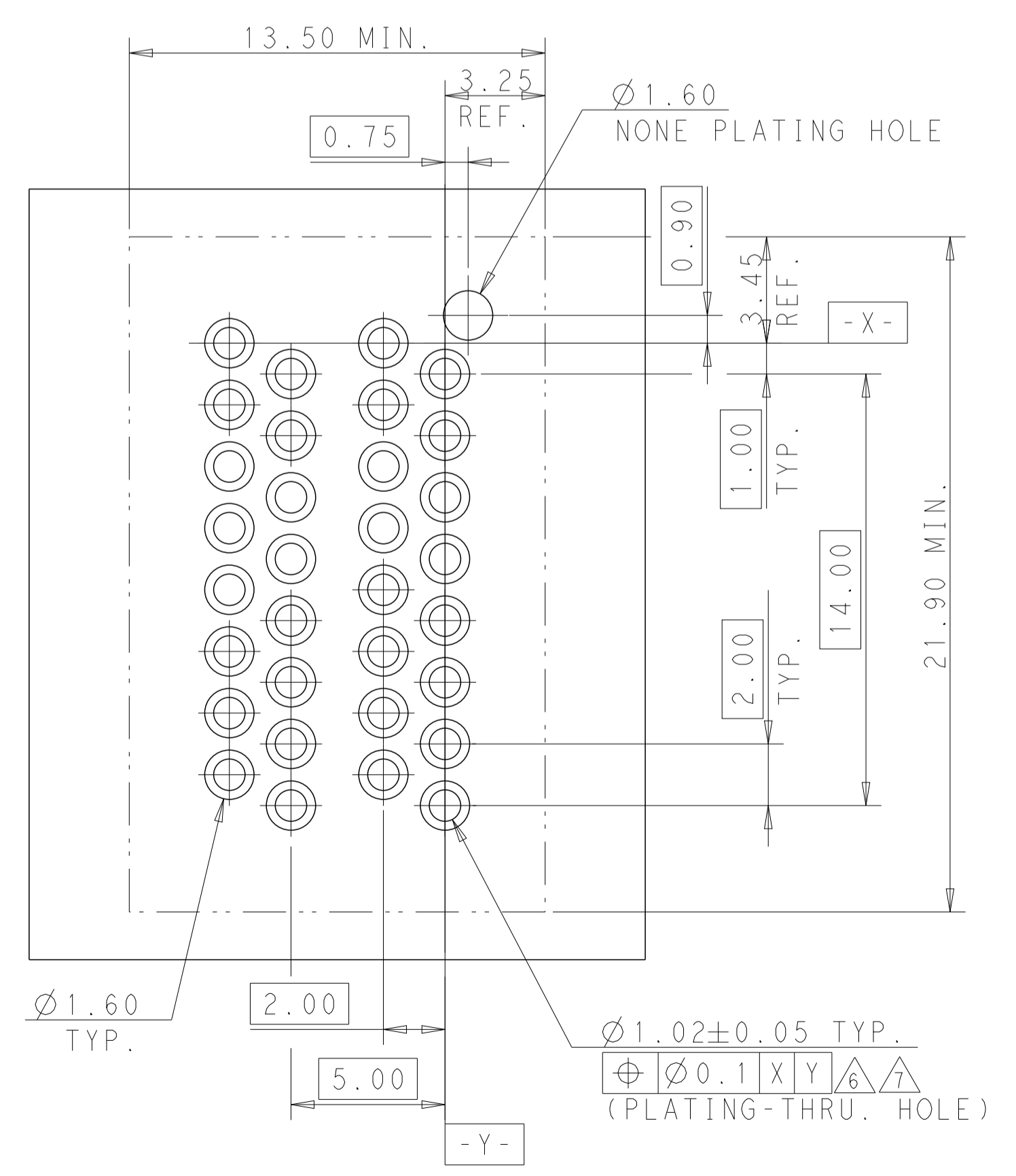

THIS DRAWING IS A CONTROLLED DOCUMENT.

DWN: THOMAS_ZHAO 28JUN2013
 CHK: SUNY_ZHAO 28JUN2013
 APVD: SUNY_ZHAO 28JUN2013

NAME: VERTICAL RECEPTACLE PRESS FIT MUTIL-BEAM HD W/GUIDELESS Customer Drawing

SIZE: A1 CAGE CODE: DRAWING NO: C=2204423

SCALE: 5:1 SHEET 6 OF 6 REV: A10

MATERIAL: $\triangle 2$ FINISH: $\triangle 3$

TE Connectivity