

# CABLINE® -UM

Fully-shielded and multi-point ground, Mechanical lock, High-data-rate transfer (40 Gbps/lane PAM3), 0.4 mm pitch, Right angle vertical mating type micro-coaxial connector

**Product Specifications:**

Mating type	Right Angle Vertical	
Board Pitch	0.4 mm	
Wiping Length	0.65 mm	
Mated Size	Height	With Lock Cover: 2.35 mm max.
		Without Lock Cover: 2.15 mm max.
		With Pull Tape Holder: 2.35 mm max.
Mated Size	Width	5.0 + (0.4 x pin count) mm
	Depth	5.0 mm with lock cover
Pin Counts	Range	Up to 70
	Available	30, 40, 50, 60, 70

**Applicable Cable Size:**

Maximum O.D.	0.4 mm
Micro-Coaxial for Signal	45 ohm: AWG 38 or smaller 50 ohm: AWG 40 or smaller
Twinaxial	AWG 40, 42
Discrete	AWG 34 or smaller

**Applicable Standards (Reference Only):**

USB4 Gen4 (40 Gbps/ Lane PAM3),  
DisplayPort UHBR20 (20 Gbps/ Lane)

\* Please inquire for pin counts not listed or outside of the pin count range.

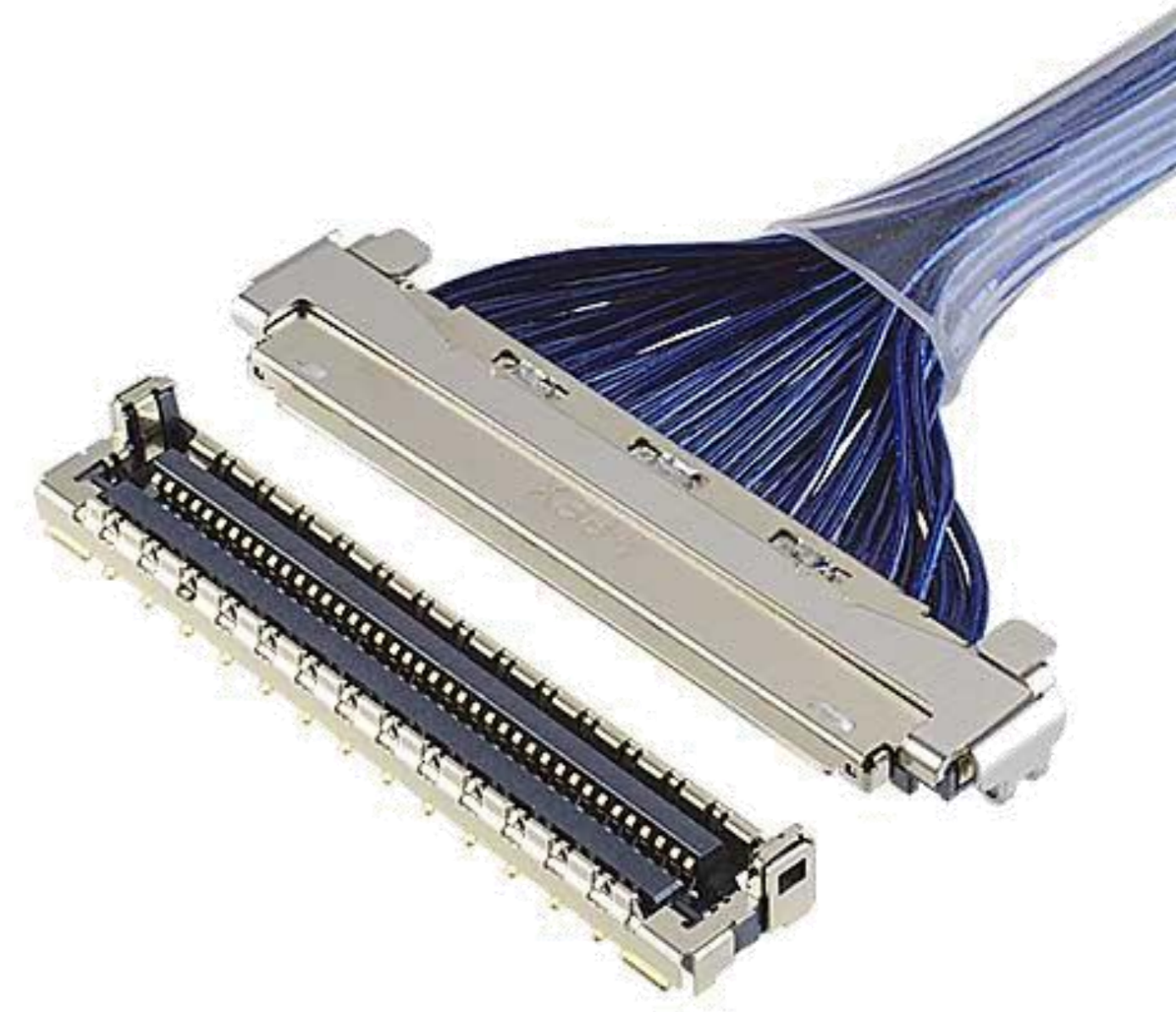

## ▶ ZenShield® fully-shielded with multi-point grounds is ideal for EMC solutions

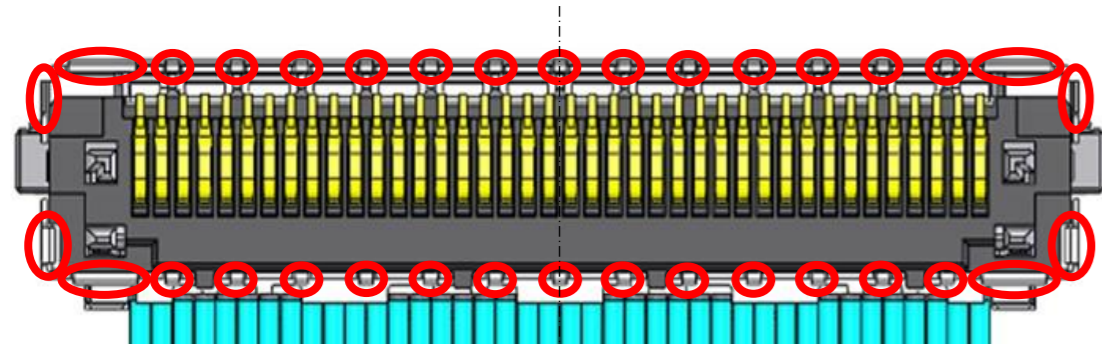

View From Underside

○ Ground SMT points

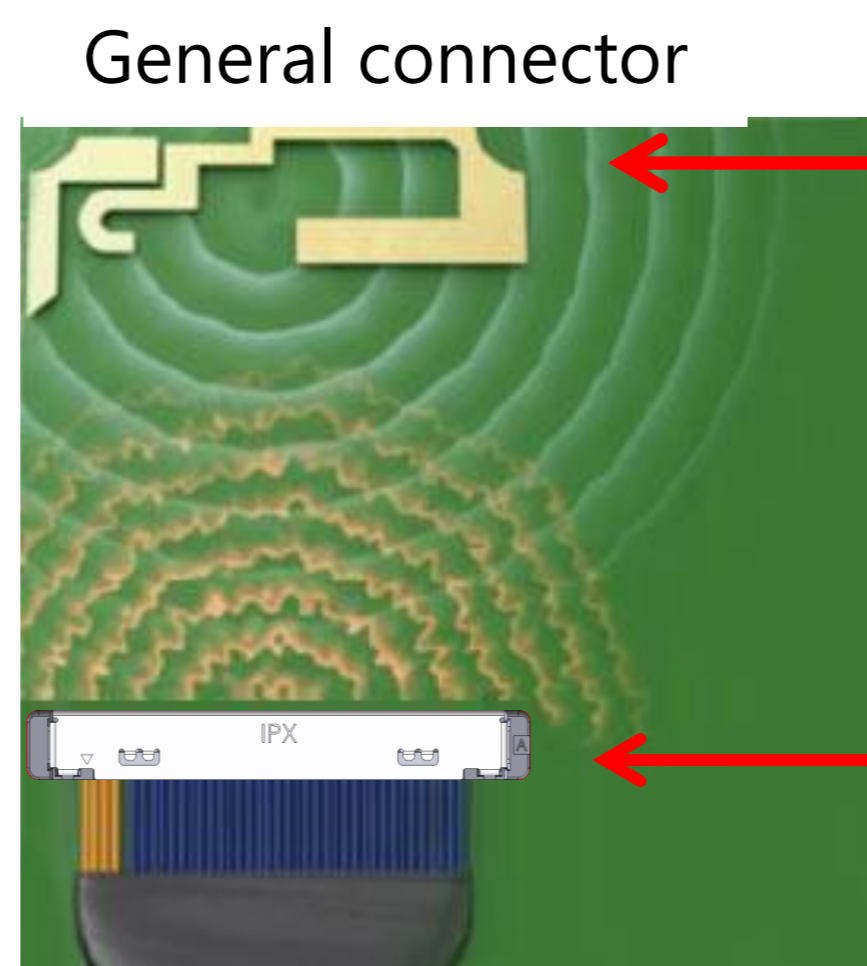

ZenShield® connector

Connectors can be placed closer to antenna

## ▶ Lock cover and 0.65 mm min. wiping length provides high contact reliability

With Lock Cover ---enhanced mating retention force

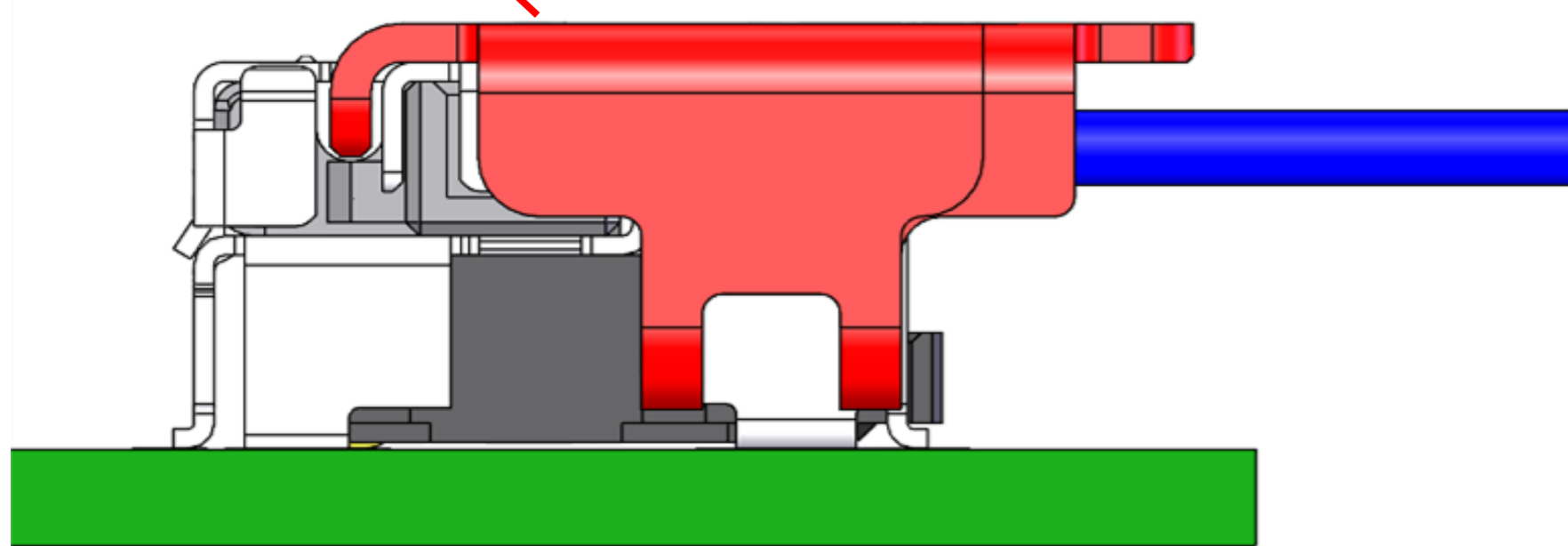

Wiping length: 0.65 mm min.

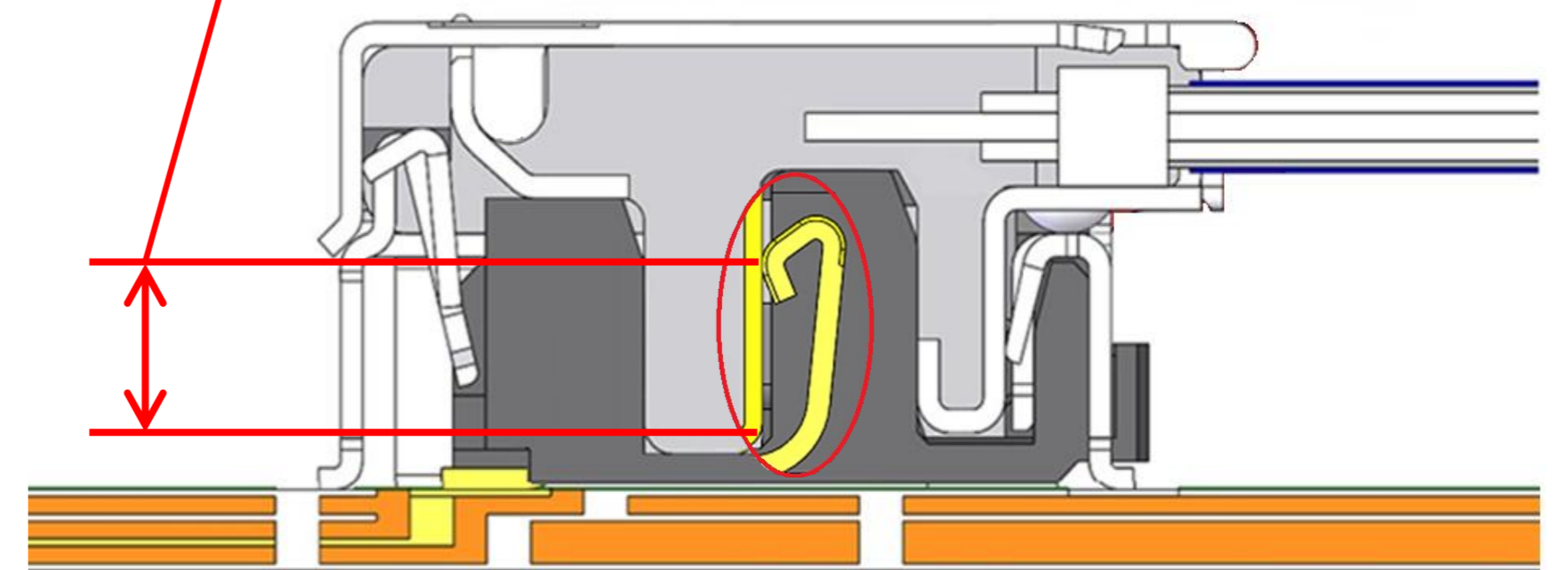

## ▶ High-data-rate transfer, ideal for 40 Gbps/lane PAM3 applications

**Measurement results**

Connector: CABLINE-UM 40 pin  
Cable: Micro-coaxial cable  
AWG 40, 45 ohm , Length : 100 mm  
Pin Assignment: GSSGSSG

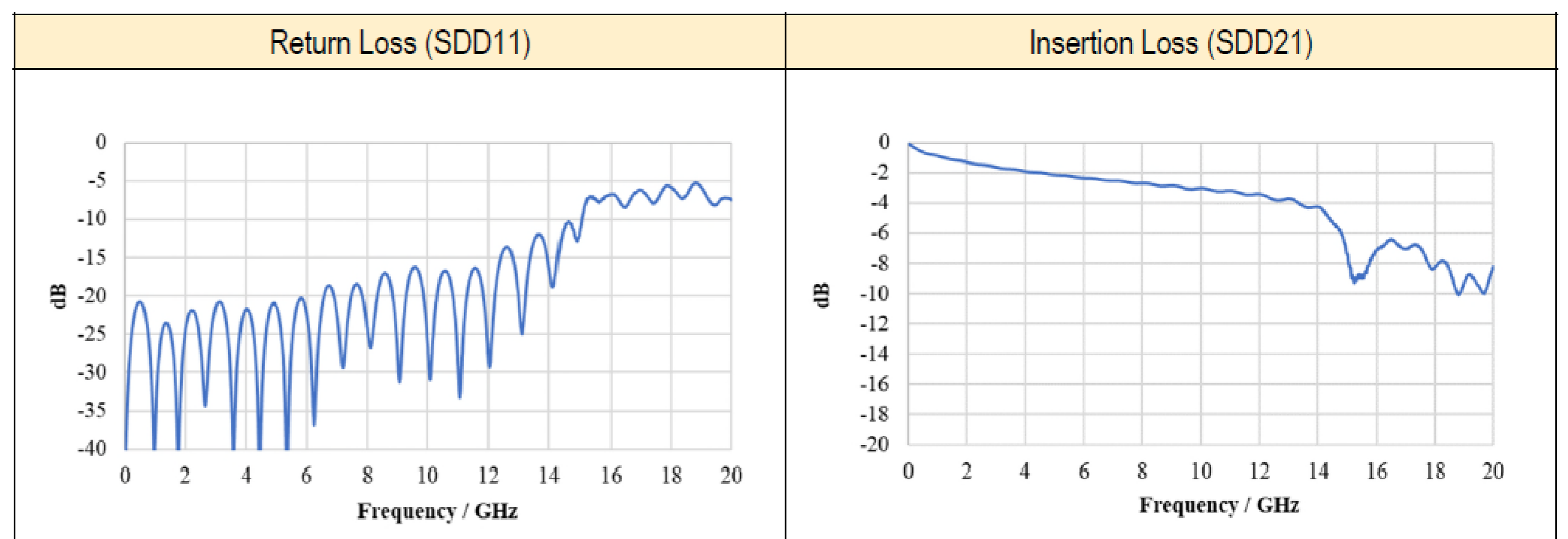

# CABLINE<sup>®</sup> -UM standard harness

- ◆ Please click the part number to get its 2D drawing.
- ◆ Please be advised that if it becomes necessary to change the harness specifications, the part number will also need to be updated. The following part number is valid only when used with the harness specifications shown below.
- ◆ Please contact us via [Inquiry form](#) for other harness specifications.

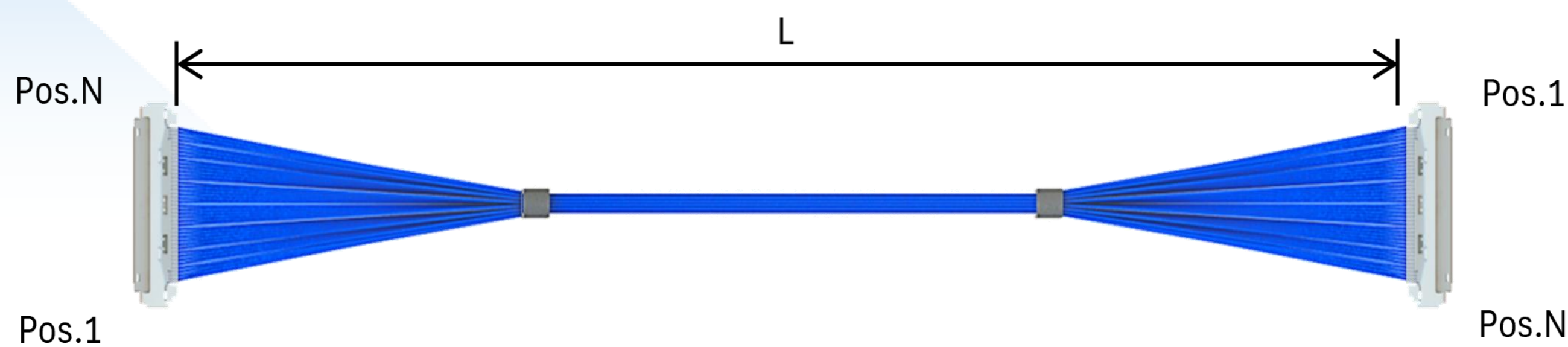

Part Number Description	Part Number (Link to Drawing)	Sample available
CABLINE-UM harness 30pin micro-coaxial 40AWG L=100mm 1-N	<a href="#">82187-100B-02-D</a>	<a href="#">Buy from Digikey</a>
CABLINE-UM harness 30pin micro-coaxial 40AWG L=200mm 1-N	<a href="#">81465-100B-02-D</a>	<a href="#">Buy from Digikey</a>
CABLINE-UM harness 30pin micro-coaxial 40AWG L=300mm 1-N	<a href="#">82286-100B-02-D</a>	<a href="#">Buy from Digikey</a>
CABLINE-UM harness 40pin micro-coaxial 40AWG L=100mm 1-N	<a href="#">82451-100B-02-D</a>	<a href="#">Buy from Digikey</a>
CABLINE-UM harness 40pin micro-coaxial 40AWG L=200mm 1-N	<a href="#">81466-100B-02-D</a>	<a href="#">Buy from Digikey</a>
CABLINE-UM harness 40pin micro-coaxial 40AWG L=300mm 1-N	<a href="#">82452-100B-02-D</a>	<a href="#">Buy from Digikey</a>
CABLINE-UM harness 50pin micro-coaxial 40AWG L=200mm 1-N	<a href="#">82285-100B-02-D</a>	<a href="#">Buy from Digikey</a>
CABLINE-UM harness 60pin micro-coaxial 40AWG L=200mm 1-N	<a href="#">82147-100B-02-D</a>	<a href="#">Buy from Digikey</a>

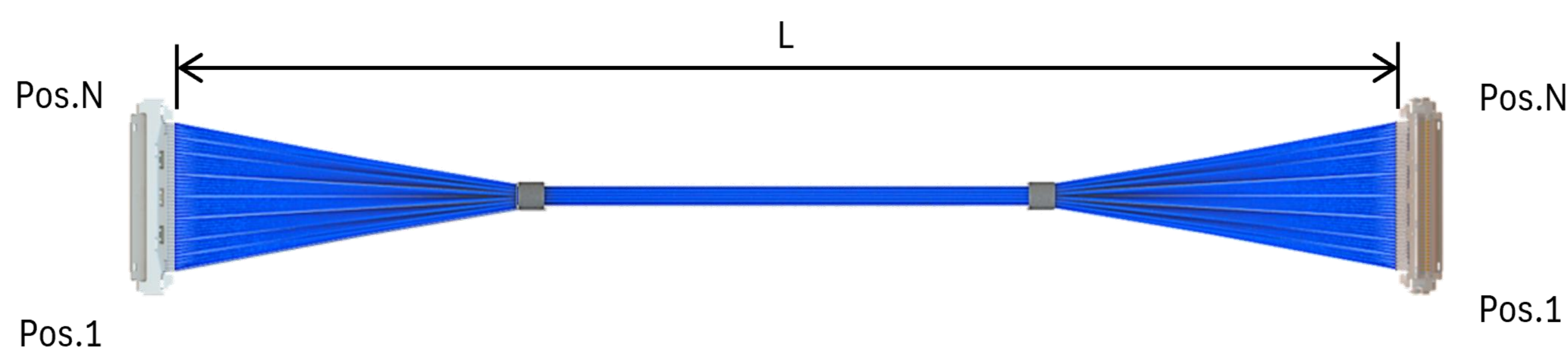

Part Number Description	Part Number (Link to Drawing)	Sample available
CABLINE-UM harness 30pin micro-coaxial 40AWG L=100mm 1-1	<a href="#">82674-100B-01-D</a>	<a href="#">Contact us</a>
CABLINE-UM harness 30pin micro-coaxial 40AWG L=200mm 1-1	<a href="#">82675-100B-01-D</a>	<a href="#">Contact us</a>
CABLINE-UM harness 30pin micro-coaxial 40AWG L=300mm 1-1	<a href="#">82676-100B-01-D</a>	<a href="#">Contact us</a>
CABLINE-UM harness 40pin micro-coaxial 40AWG L=100mm 1-1	<a href="#">82677-100B-01-D</a>	<a href="#">Contact us</a>
CABLINE-UM harness 40pin micro-coaxial 40AWG L=200mm 1-1	<a href="#">82678-100B-01-D</a>	<a href="#">Contact us</a>
CABLINE-UM harness 40pin micro-coaxial 40AWG L=300mm 1-1	<a href="#">82679-100B-01-D</a>	<a href="#">Contact us</a>

# Component Parts Details

## Component Parts

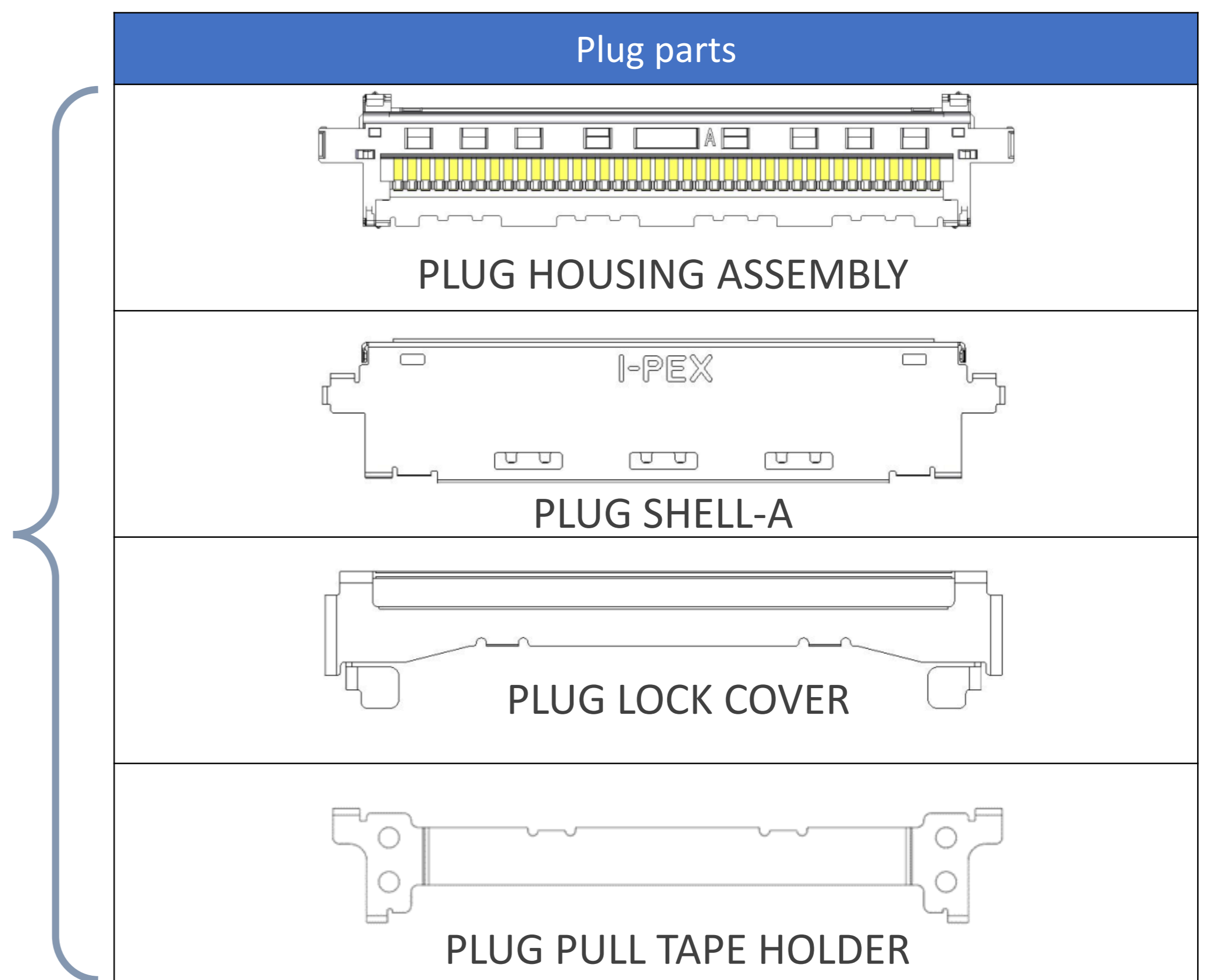
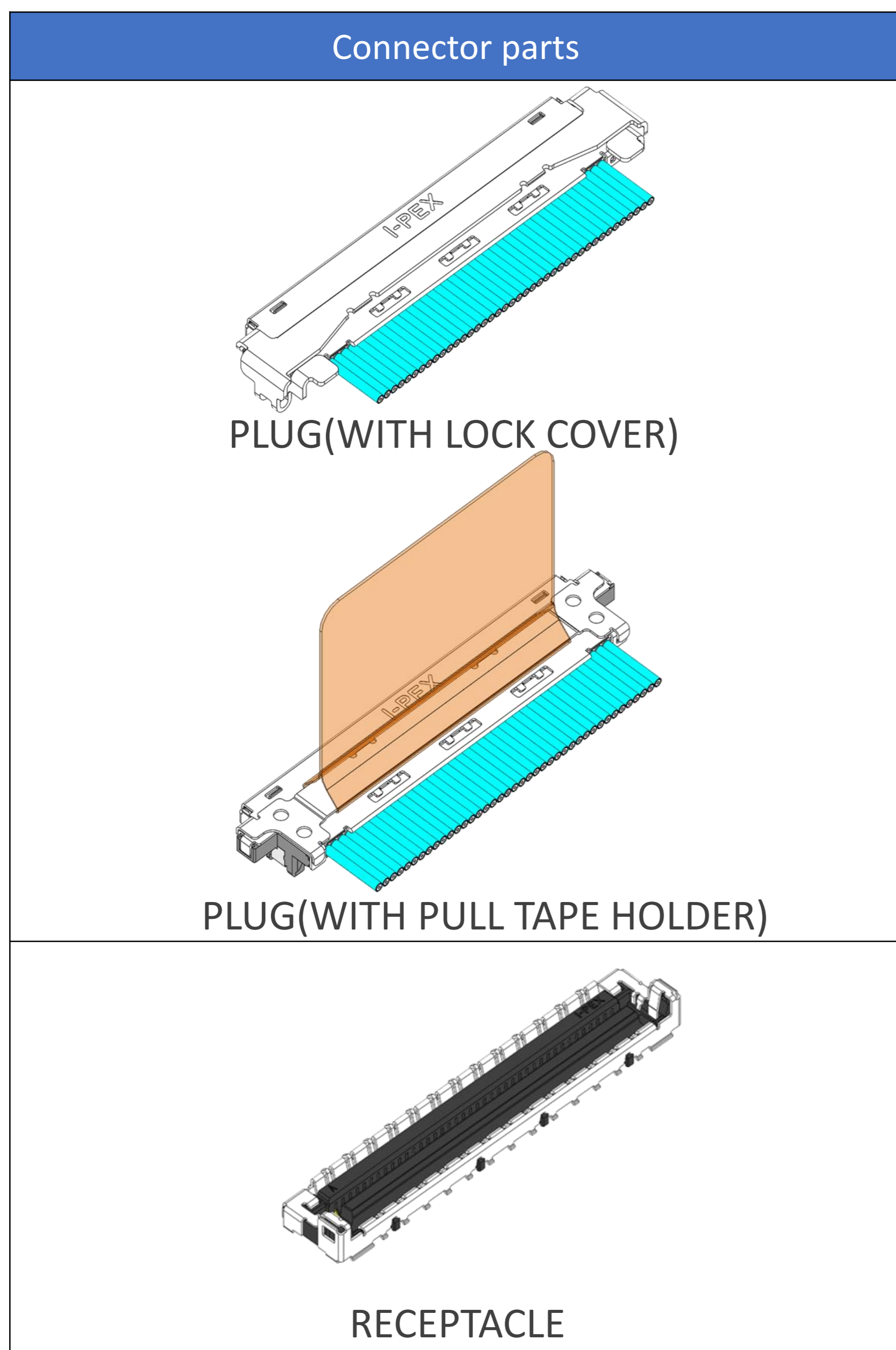

# Plug for Cable Assembly

Recommended P/N		20877-0**T-01				
PART NO.	Pos.	A	B	C	D	E
20877-030T-01	30	16.20	13.85	13.65	11.60	17.00
20877-040T-01	40	20.20	17.85	17.65	15.60	21.00
20877-050T-01	50	24.20	21.85	21.65	19.60	25.00
20877-060T-01	60	28.20	25.85	25.65	23.60	29.00
20877-070T-01	70	32.20	29.85	29.65	27.60	33.00

## With LOCK COVER

BONDING  
(LOCTITE 352 RECOMMENDS)

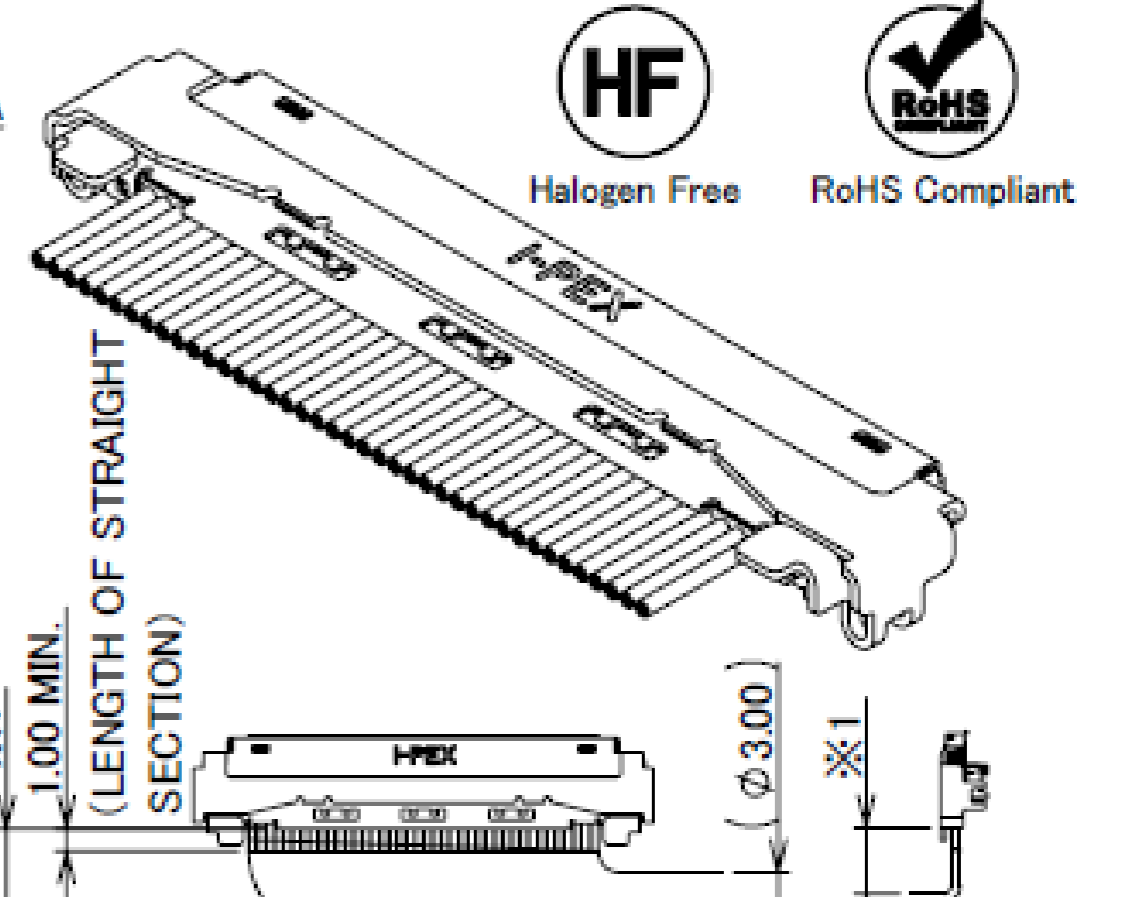
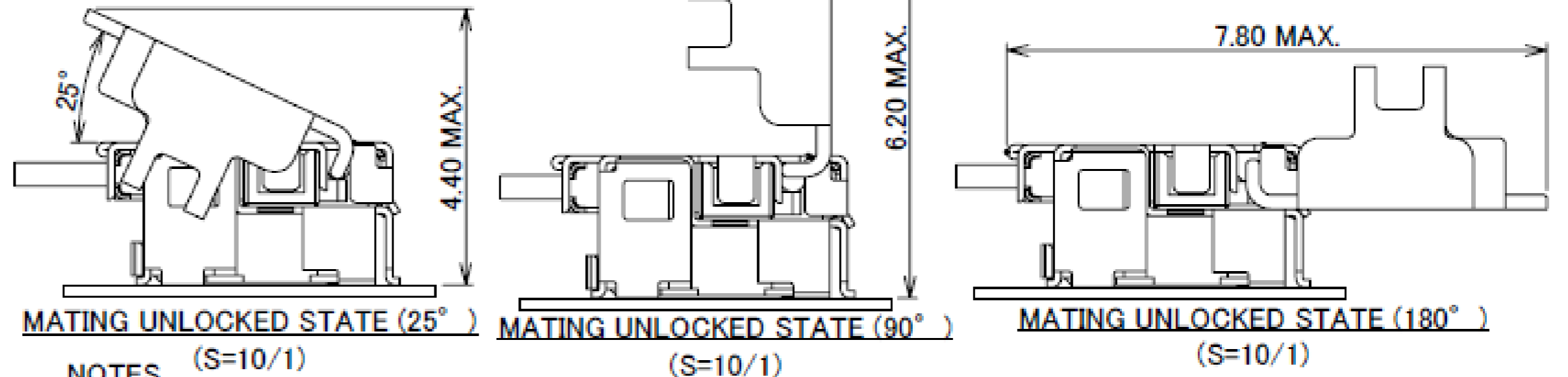
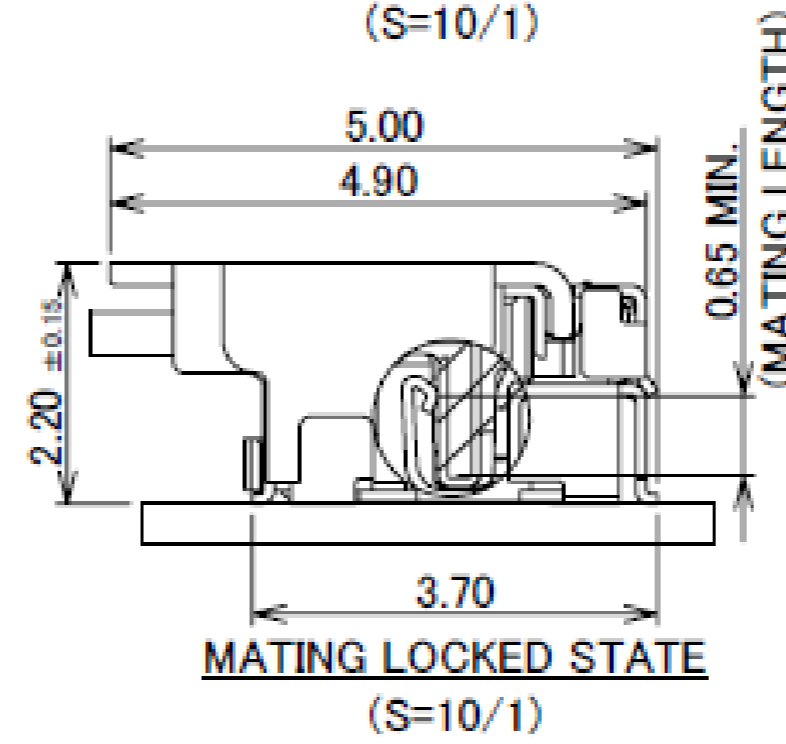
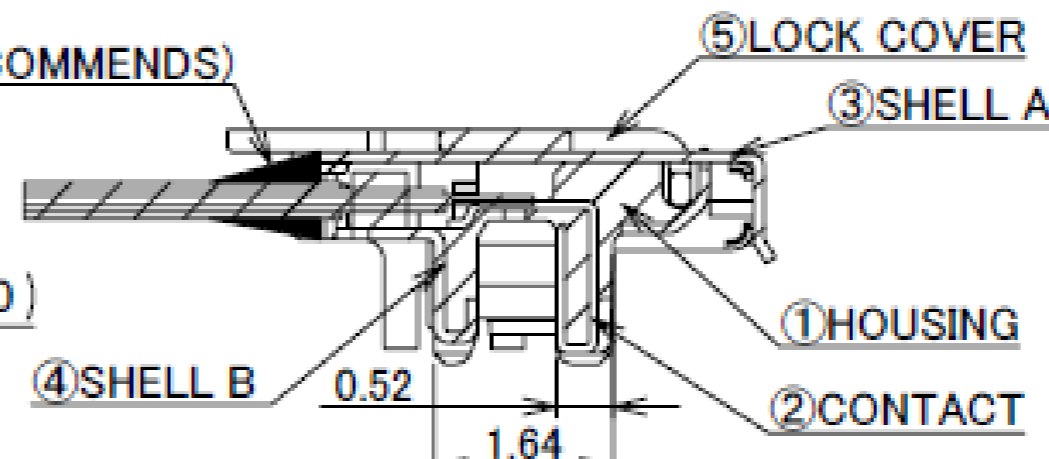
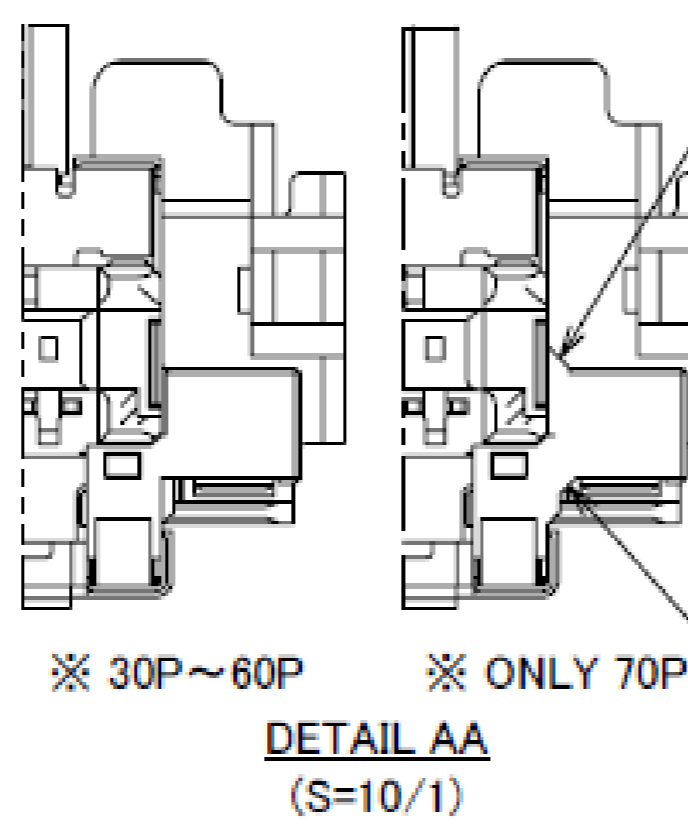
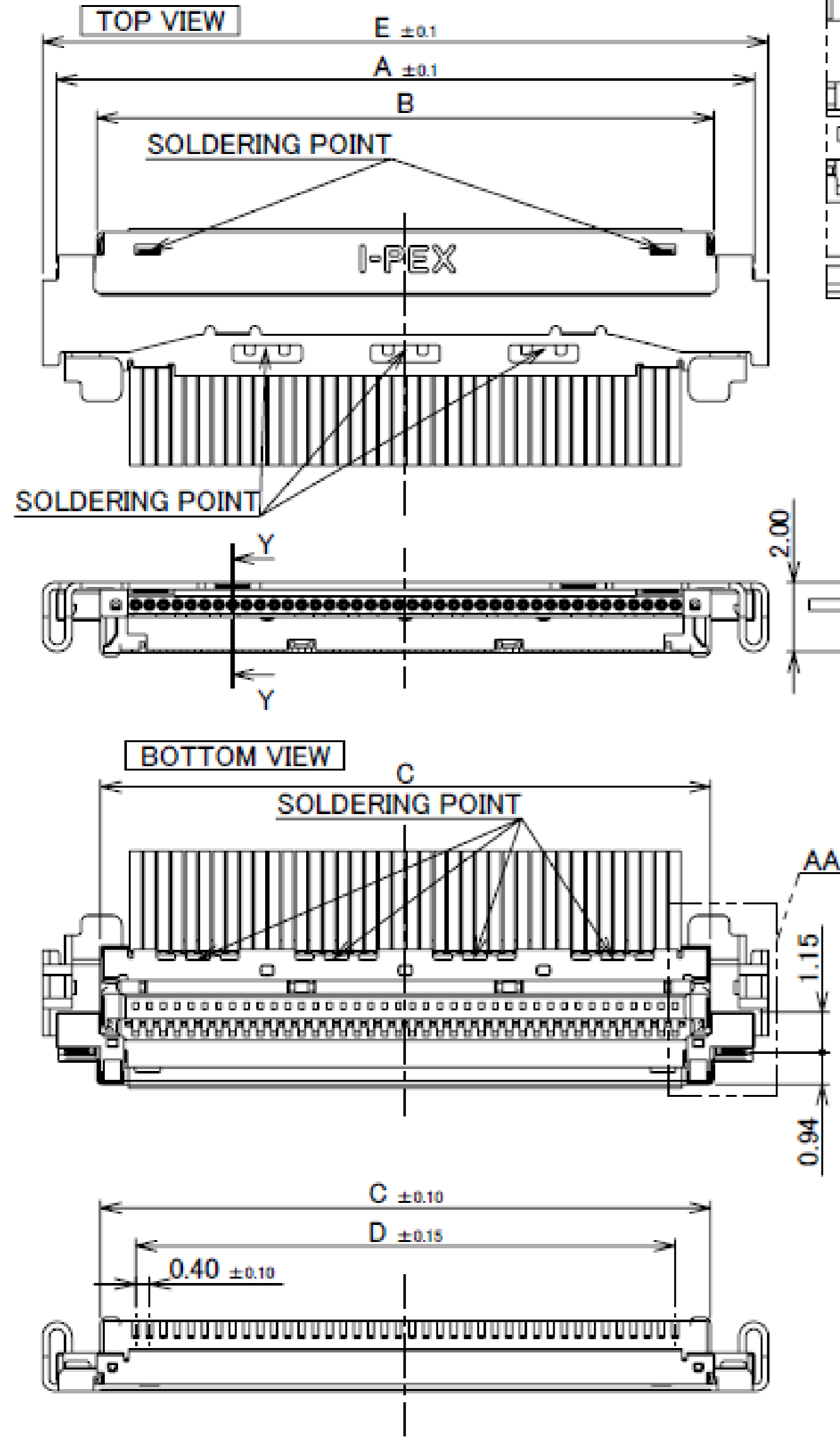

REFERENCE CABLE BENDING DIMENSIONS  
※1: THE BEND DIMENSIONS MAY VARY BASED ON THE SIZE AND QUANTITY OF CABLES. PLEASE CONFIRM THE MINIMUM BENDING RADIUS WITH I-PEX OR THE HARNESS MANUFACTURER.

### NOTES.

1. THE LOCK COVER MUST BE OPENED AT LEAST 25° TO PROPERLY UNMATE THE PLUG/HARNESS.

5	LOCK COVER	PHOSPHOR BRONZE	ALL OVER Ni 1.0 μm MIN.
4	SHELL B	PHOSPHOR BRONZE	PARTIAL Au 0.003 μm MIN. OVER Ni 1.0 μm MIN.
3	SHELL A	PHOSPHOR BRONZE	PARTIAL Au 0.003 μm MIN. OVER Ni 1.0 μm MIN.
2	CONTACT	CORSON ALLOY	ALL OVER Ni 1.0 μm MIN. CONTACT & SOLDERING AREA : Au 0.03 μm MIN.
1	HOUSING	LCP	UL94V-0 ,BLACK
NO.	DISCRIPTION	MATERIAL	FINISH , REMARKS

Rev.18

Recommended P/N		20877-0**T-01			
PART NO.	Pos.	A	B	C	D
20877-030T-02	30	16.20	13.85	13.65	11.60
20877-040T-02	40	20.20	17.85	17.65	15.60
20877-050T-02	50	24.20	21.85	21.65	19.60
20877-060T-02	60	28.20	25.85	25.65	23.60
20877-070T-02	70	32.20	29.85	29.65	27.60

## Without LOCK COVER

BONDING  
(LOCTITE 352 RECOMMENDS)

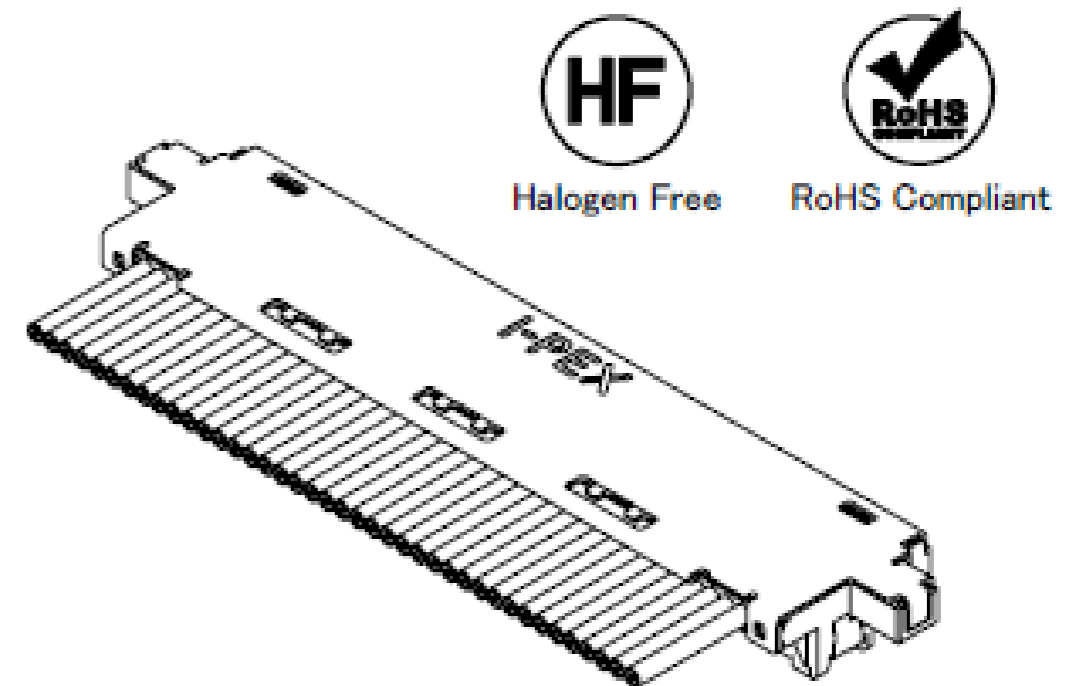
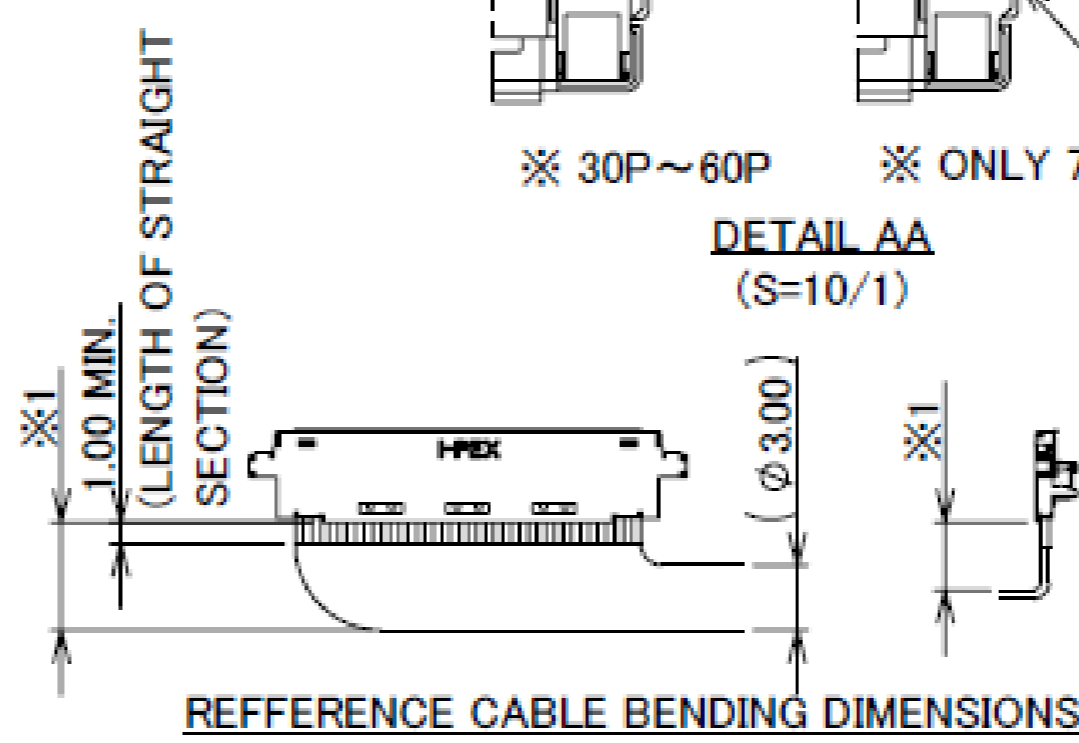
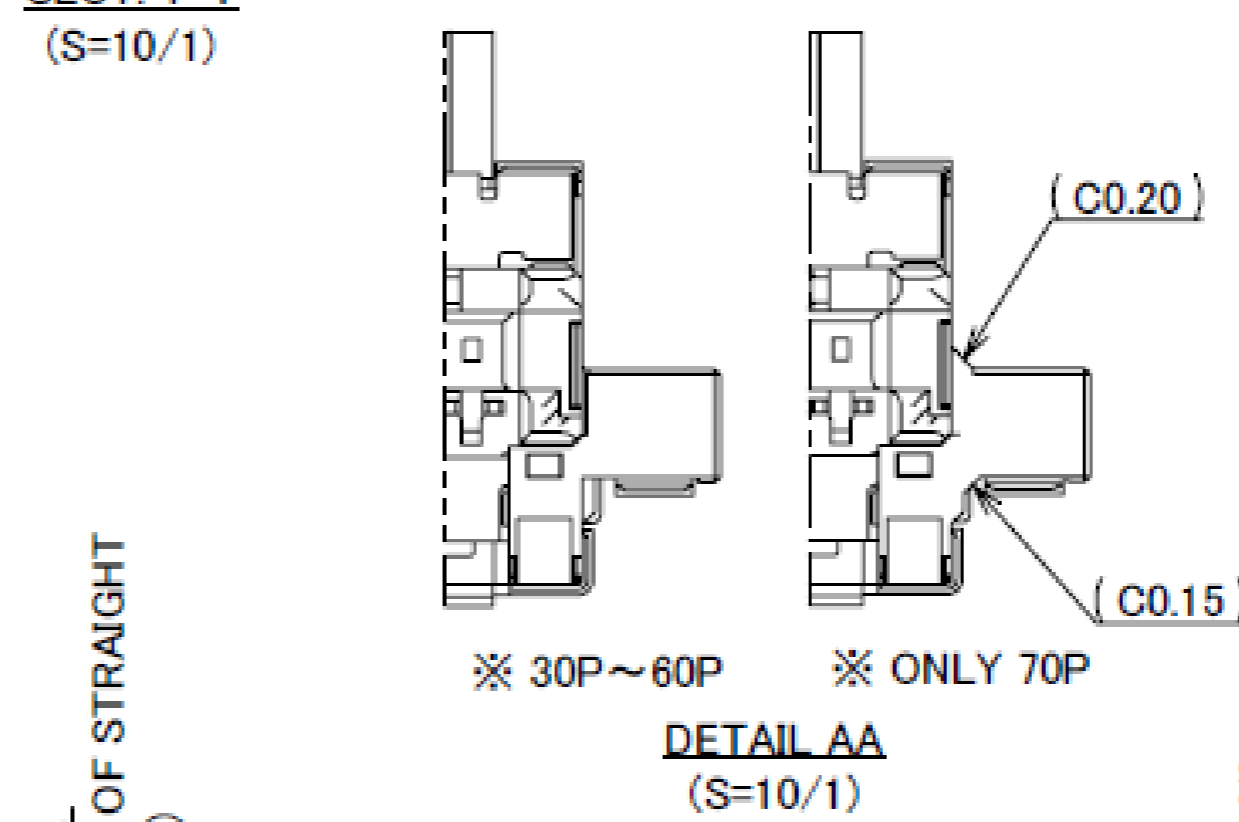
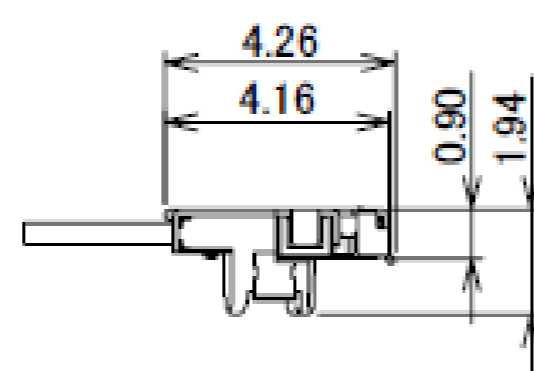
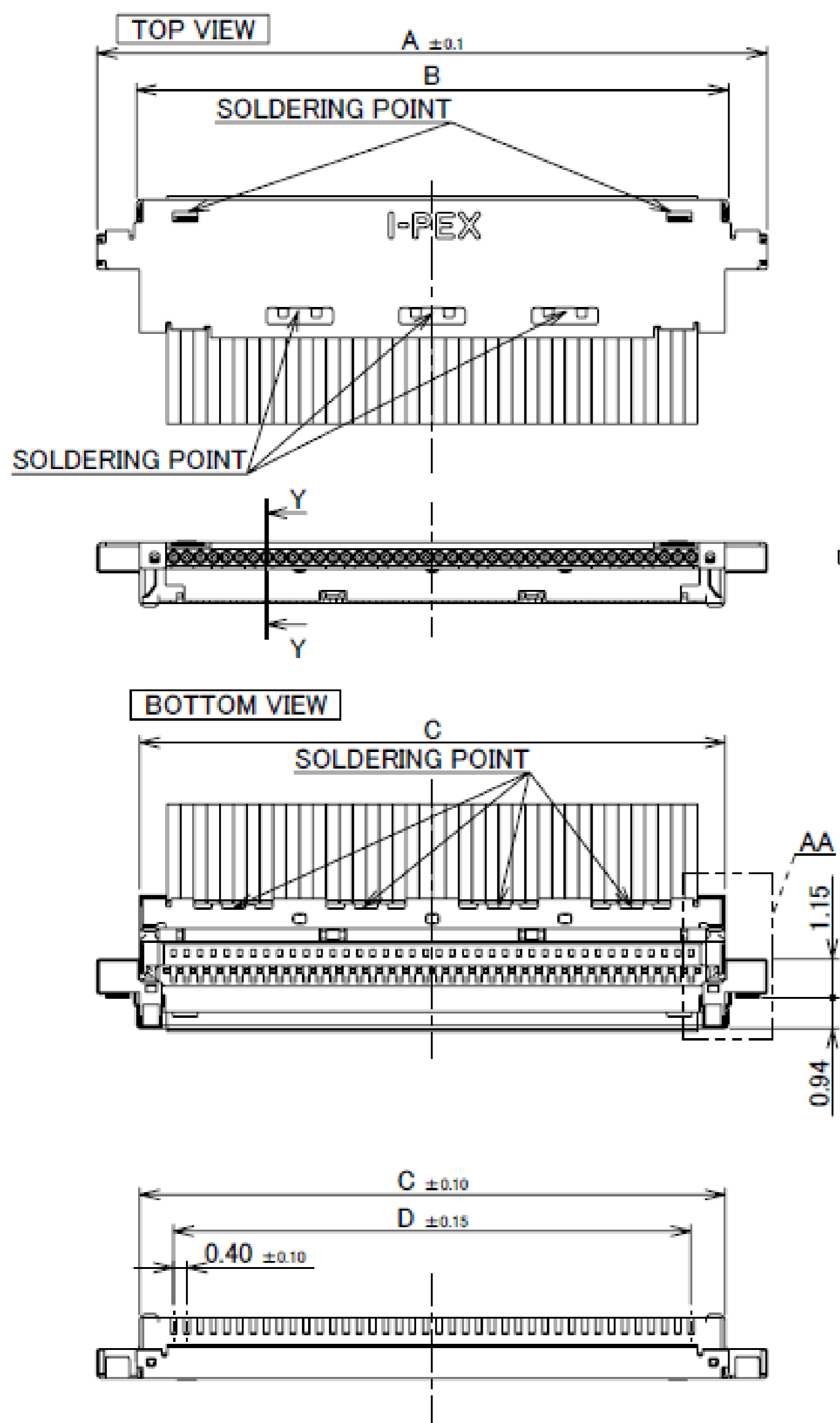

※1: THE BEND DIMENSIONS MAY VARY BASED ON THE SIZE AND QUANTITY OF CABLES. PLEASE CONFIRM THE MINIMUM BENDING RADIUS WITH I-PEX OR THE HARNESS MANUFACTURER.

4	SHELL B	PHOSPHOR BRONZE	PARTIAL Au 0.003 μm MIN. OVER Ni 1.0 μm MIN.
3	SHELL A	PHOSPHOR BRONZE	PARTIAL Au 0.003 μm MIN. OVER Ni 1.0 μm MIN.
2	CONTACT	CORSON ALLOY	ALL OVER Ni 1.0 μm MIN. CONTACT & SOLDERING AREA : Au 0.03 μm MIN.
1	HOUSING	LCP	UL94V-0 ,BLACK
NO.	DISCRIPTION	MATERIAL	FINISH , REMARKS

Rev.18

# Plug for Cable Assembly

Recommended P/N		20877-0**T-01					
PART NO.	Pos.	A	B	C	D	F	G
20877-030T-03	30	16.20	13.85	13.65	11.60	9.00	10.00
20877-040T-03	40	20.20	17.85	17.65	15.60	13.00	14.00
20877-050T-03	50	24.20	21.85	21.65	19.60	17.00	18.00
20877-060T-03	60	28.20	25.85	25.65	23.60	21.00	22.00
20877-070T-03	70	32.20	29.85	29.65	27.60	25.00	26.00

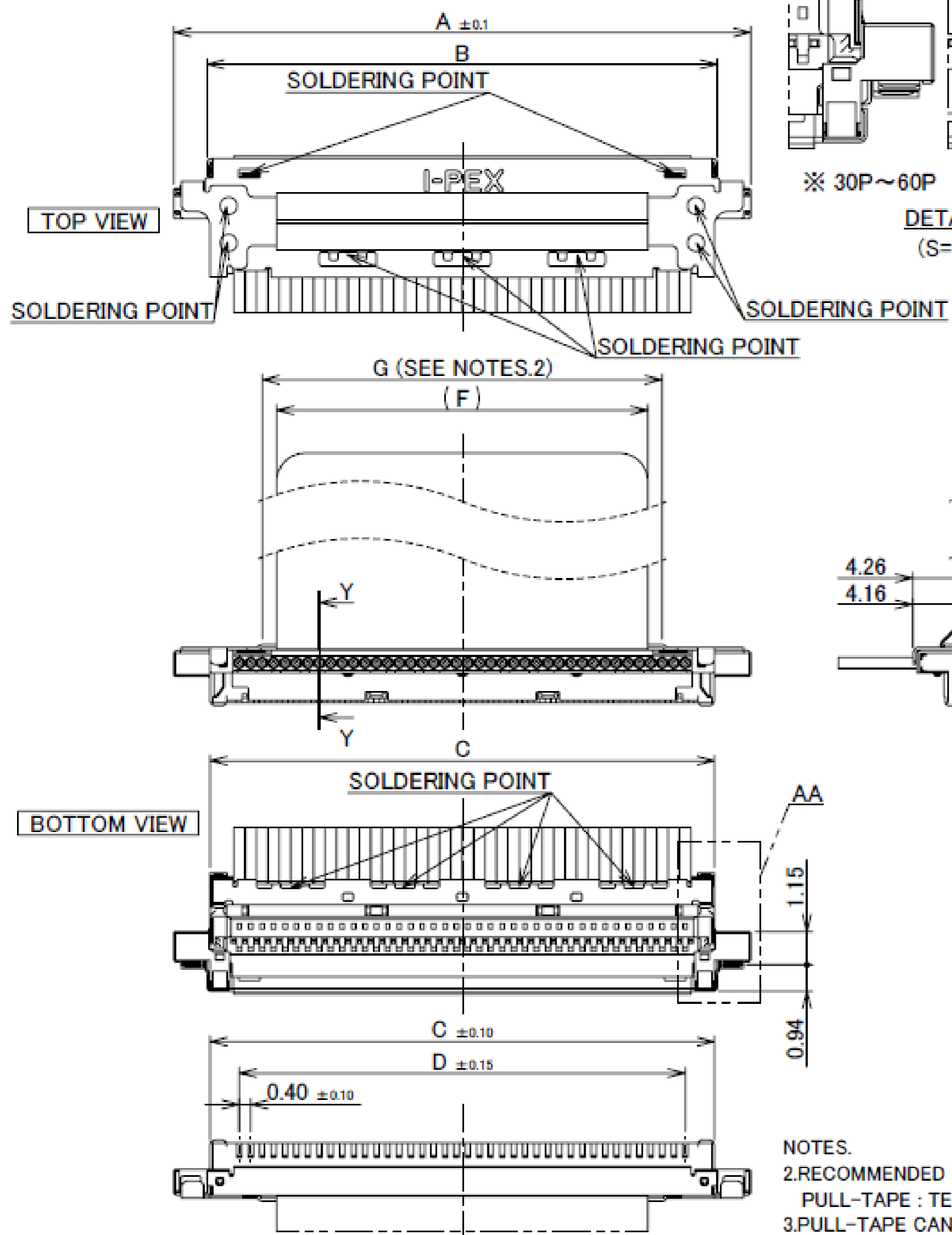

## With PULL TAPE HOLDER

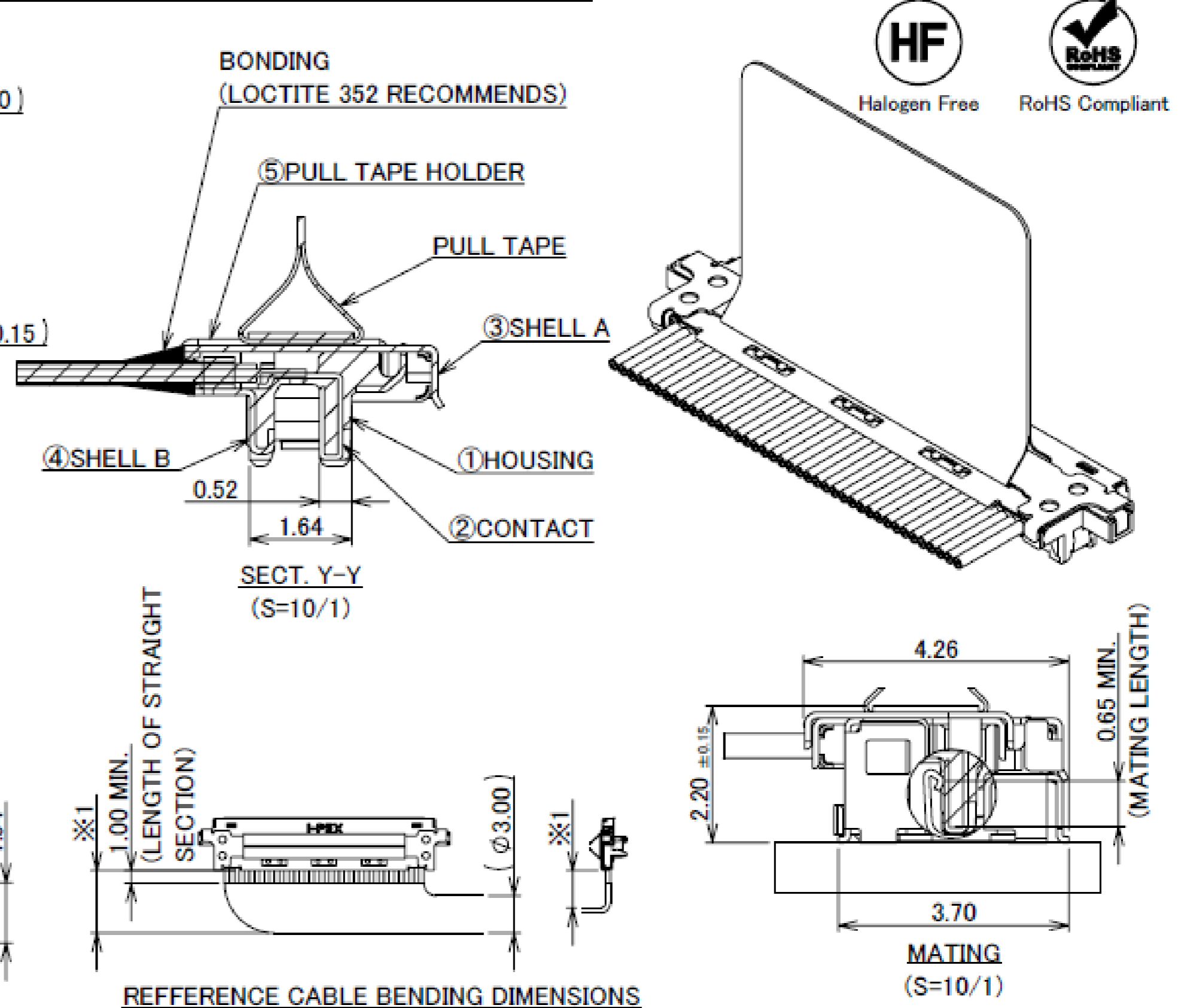

※1: THE BEND DIMENSIONS MAY VARY BASED ON THE SIZE AND QUANTITY OF CABLES. PLEASE CONFIRM THE MINIMUM BENDING RADIUS WITH I-PEX OR THE HARNESS MANUFACTURER.

NO.	DISCRPTION	MATERIAL	FINISH , REMARKS
5	PULL TAPE HOLDER	PHOSPHOR BRONZE	PARTIAL Au 0.003 μm MIN. OVER Ni 1.0 μm MIN.
4	SHELL B	PHOSPHOR BRONZE	PARTIAL Au 0.003 μm MIN. OVER Ni 1.0 μm MIN.
3	SHELL A	PHOSPHOR BRONZE	PARTIAL Au 0.003 μm MIN. OVER Ni 1.0 μm MIN.
2	CONTACT	CORSON ALLOY	ALL OVER Ni 1.0 μm MIN. CONTACT & SOLDERING AREA : Au 0.03 μm MIN.
1	HOUSING	LCP	UL94V-0 ,BLACK

NOTES.  
2.RECOMMENDED PULL-TAPE  
PULL-TAPE : TERAOKA's INSULATION TAPE No.650S(#50) t=0.08  
3.PULL-TAPE CAN BE PUT WITHIN THE RANGE OF "G" STRIAIGHT AREA.

Rev.18

PART NO.	Pos.	D
20877-030T-0#	30	11.60
20877-040T-0#	40	15.60
20877-050T-0#	50	19.60
20877-060T-0#	60	23.60
20877-070T-0#	70	27.60

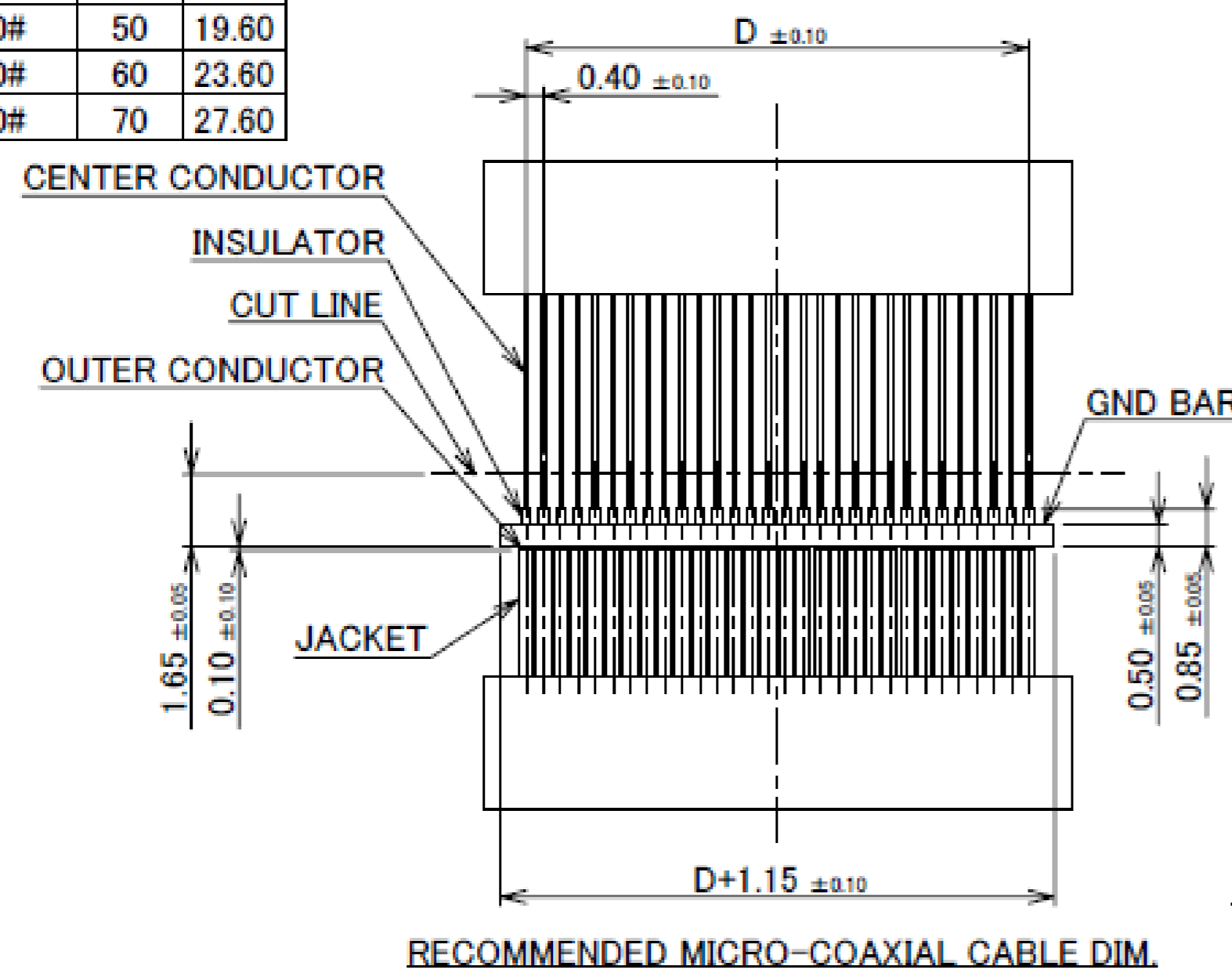

**CHARACTERISTIC IMPEDANCE MATCHING MICRO-COAXIAL CABLE**

	a
#38	0.12
#40	0.09
#42	0.075
#44	0.063

**CHARACTERISTIC IMPEDANCE UN-MATCHING MICRO-COAXIAL CABLE**

	a
#36	0.15

MICRO-COAXIAL CABLE #36 : NOT RECOMMENDED FOR HIGH SPEED SIGNAL TRANSFER

MICRO-COAXIAL CABLE AWG #\*\*

φa <sup>+0.05</sup>/<sub>-0.02</sub> (AFTER SOLDERING COAT)  
φ0.30 MAX.  
0.51 <sup>+0.07</sup>/<sub>-0.01</sub>  
φ0.40 MAX.

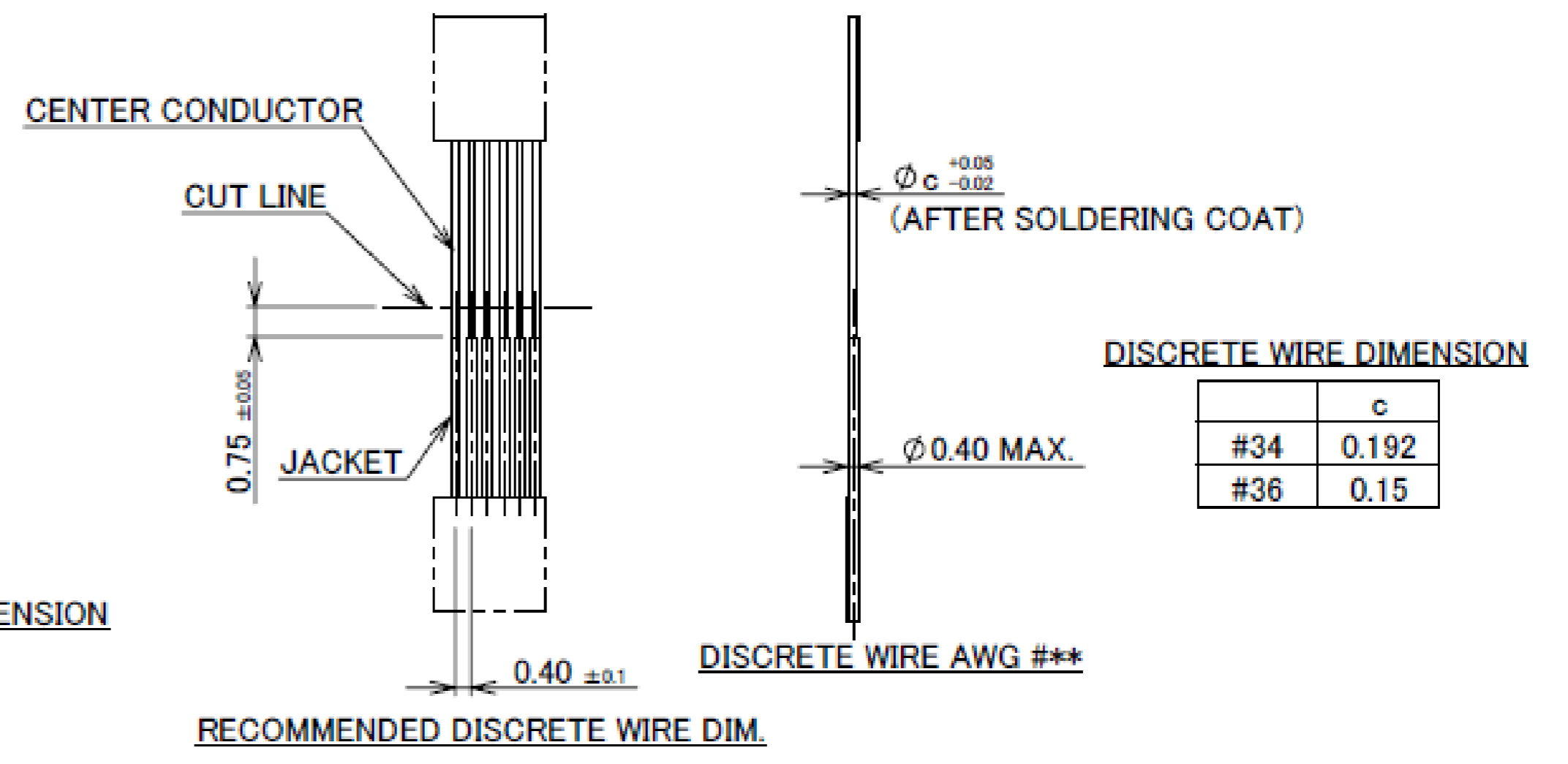
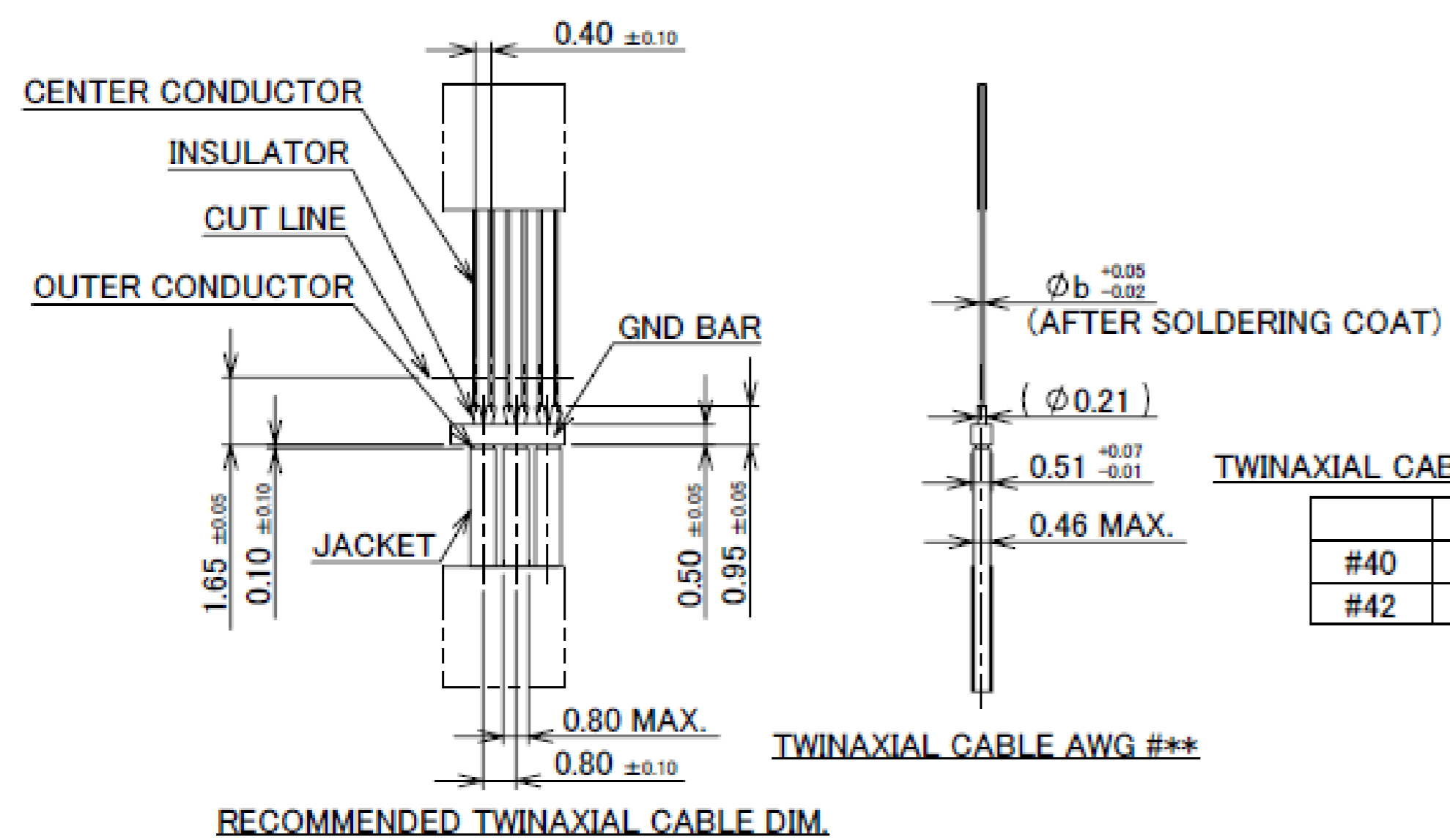

Rev.18



# Plug for Cable Assembly

ITEMS	SPECIFICATION
APPLICABLE CABLE	MICRO-COAXIAL CABLE : AWG #44 , 42 , 40 , 38 , 36 DISCRETE WIRE : AWG #36 , 34 TWINAXIAL CABLE : AWG #40 , 42
RATED VOLTAGE	100V AC (PER CONTACT PIN) ※THIS IS THE RATED VOLTAGE OF THE CONNECTOR. PLEASE NOTE THAT THE RATED VOLTAGE MAY VARY IN THE HARNESS DEPENDING ON THE CABLES USED.
RATED AMPERAGE (FOR CONTACT)	0.15A AC/DC [AWG #44] PER CONTACT PIN/UP TO 60 CONTACTS 0.24A AC/DC [AWG #42] PER CONTACT PIN/UP TO 49 CONTACTS 0.3A AC/DC [AWG #40] PER CONTACT PIN/UP TO 38 CONTACTS 0.5A AC/DC [AWG #38] PER CONTACT PIN/UP TO 19 CONTACTS 0.8A AC/DC [AWG #36] PER CONTACT PIN/UP TO 12 CONTACTS 1.0A AC/DC [AWG #34] PER CONTACT PIN/UP TO 10 CONTACTS ※TESTING BY A REAL MACHINE IS RECOMMENDED BECAUSE TEMPERATURE RISE MAY AFFECTED BY ACTUAL SITUATION.
OPERATING TEMPERATURE	233 TO 378K (-40°C TO +105°C)
OPERATING HUMIDITY	85% MAX.
CONTACT RESISTANCE	INITIAL : 180mohm MAX.(AWG #34) / AFTER TEST : <math>\triangleleft</math>140mohm MAX. 275mohm MAX.(AWG #36) 360mohm MAX.(AWG #38) 600mohm MAX.(AWG #40) 700mohm MAX.(AWG #42) 1080mohm MAX.(AWG #44)
GROUND SHELL RESISTANCE	INITIAL : 50mohm MAX. / AFTER TEST : <math>\triangleleft</math>40mohm MAX.
INSULATION RESISTANCE	INITIAL : 1000Mohm MIN. / AFTER TEST : 500Mohm MIN.
DIELECTRIC WITHSTANDING VOLTAGE	AC250V 1min
DURABILITY	30 CYCLES
MATING FORCE (INITIAL / AFTER TEST)	30P : 34.00N MAX. 60P : 52.00N MAX. 40P : 40.00N MAX. 70P : 58.00N MAX. 50P : 46.00N MAX.
UNMATING FORCE (INITIAL / AFTER TEST)	30P : 3.0N MIN. 60P : 6.0N MIN. 40P : 4.0N MIN. 70P : 7.0N MIN. 50P : 5.0N MIN.
CABLE RETENTION FORCE	30P : 14.70N MIN. 60P : 29.40N MIN. 40P : 19.60N MIN. 70P : 34.30N MIN. 50P : 24.50N MIN.
PRODUCT SPECIFICATION	PRS-2514
TEST REPORT	TR-18067 (RECEPTACLE:20879-0**E-01) TR-18088 (RECEPTACLE:20879-0**E-02)
INSTRUCTION MANUAL	HIM-18033
ASSEMBLY MANUAL	ASM-18003
APPEARANCE CRITERIA No.	QLS-A***

※Only the single-hook pull jig is permitted for 70P.  
The dual-hook pull jig is not allowed for 70P.

Rev.18

# Plug Housing Assembly

Recommended P/N 20878-0\*\*T-01

PART No.	Pos.	A	B	C	D	E	F	G	H
20878-030T-01	30	13.65	11.60	16.20	12.01	8.00	13.00	12.65	4.00
20878-040T-01	40	17.65	15.60	20.20	16.01	12.00	17.00	16.65	8.00
20878-050T-01	50	21.65	19.60	24.20	20.01	16.00	21.00	20.65	12.00
20878-060T-01	60	25.65	23.60	28.20	24.01	20.00	25.00	24.65	16.00
20878-070T-01	70	29.65	27.60	32.20	28.01	24.00	29.00	28.65	20.00



Halogen Free RoHS Compliant

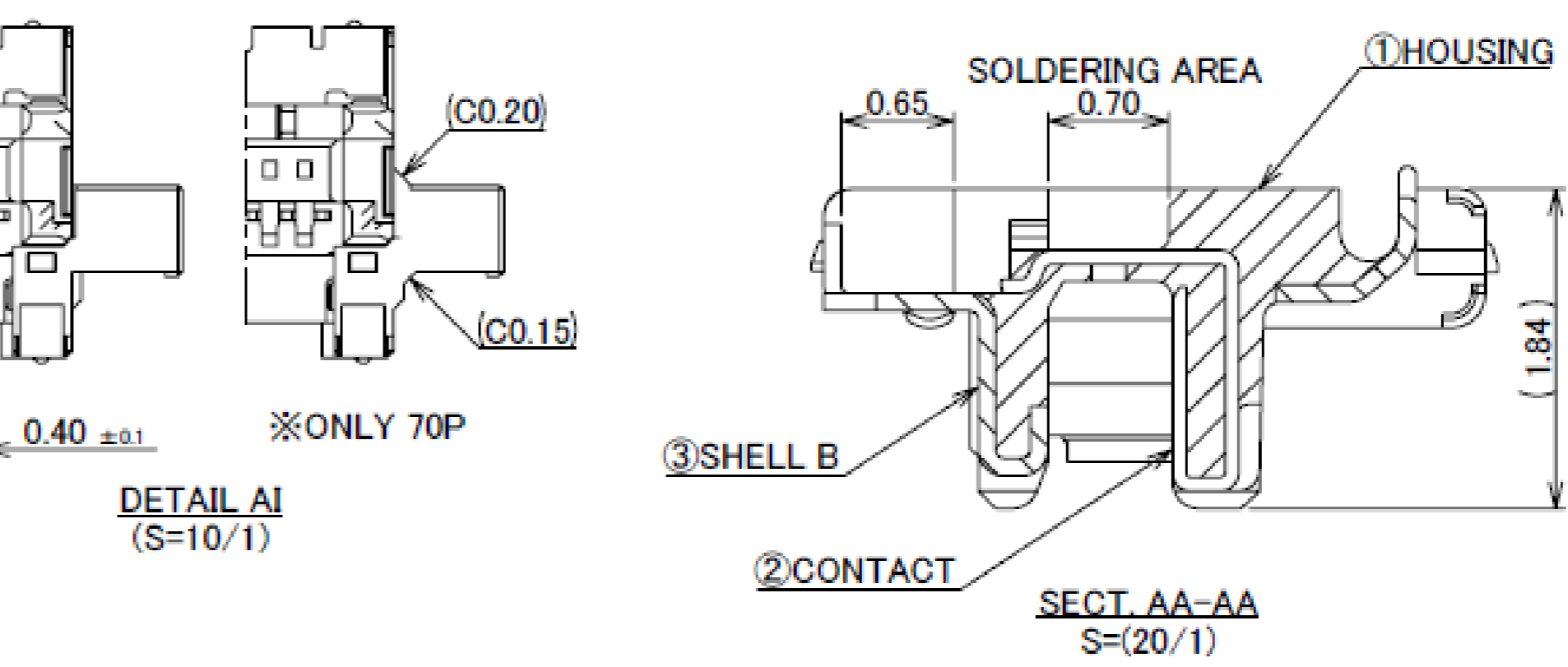
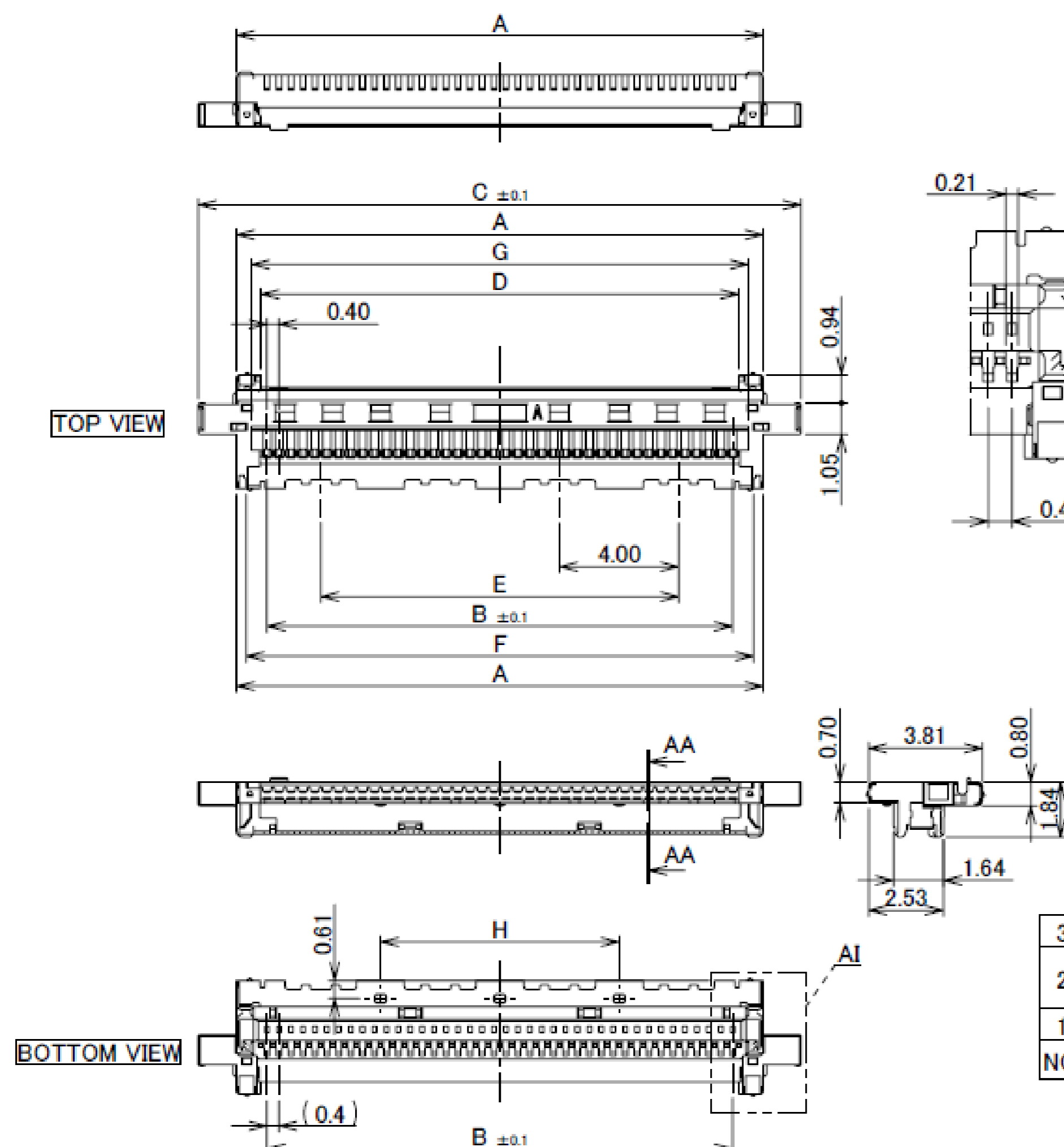
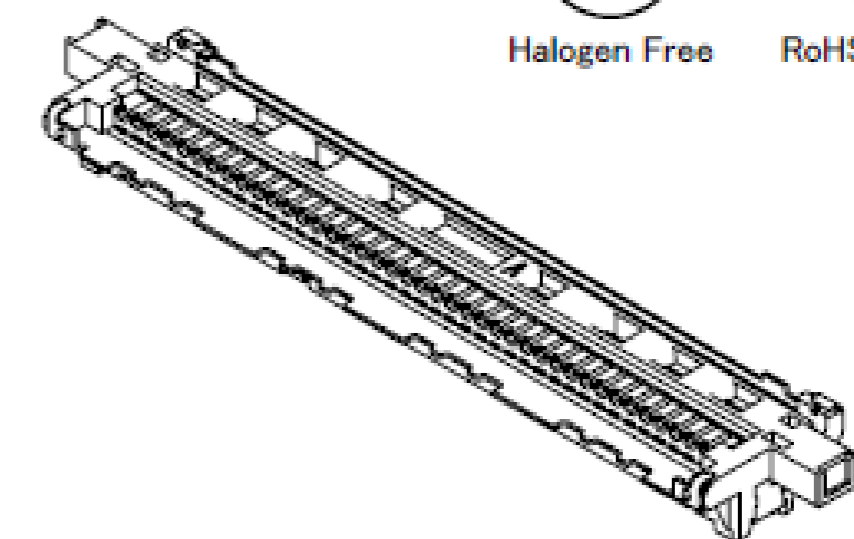

NO.	DISCRIPTION	MATERIAL	FINISH , REMARKS
3	SHELL B	PHOSPHOR BRONZE	PARTIAL Au 0.003 μm MIN. OVER Ni 1.00 μm MIN.
2	CONTACT	CORSON ALLOY	ALL OVER Ni 1.00 μm MIN. CONTACT & SOLDERING AREA : Au 0.03 μm MIN.
1	HOUSING	LCP	UL94V-0 ,BLACK

Rev.6

# Plug Shell-A

Recommended P/N		3488-0**1				
PART No.	Pos.	A	B	C	D	E
3488-0301	30	16.20	13.88	4.00	13.65	9.36
3488-0401	40	20.20	17.88	8.00	17.65	13.36
3488-0501	50	24.20	21.88	12.00	21.65	17.36
3488-0601	60	28.20	25.88	16.00	25.65	21.36
3488-0701	70	32.20	29.88	20.00	29.65	25.36

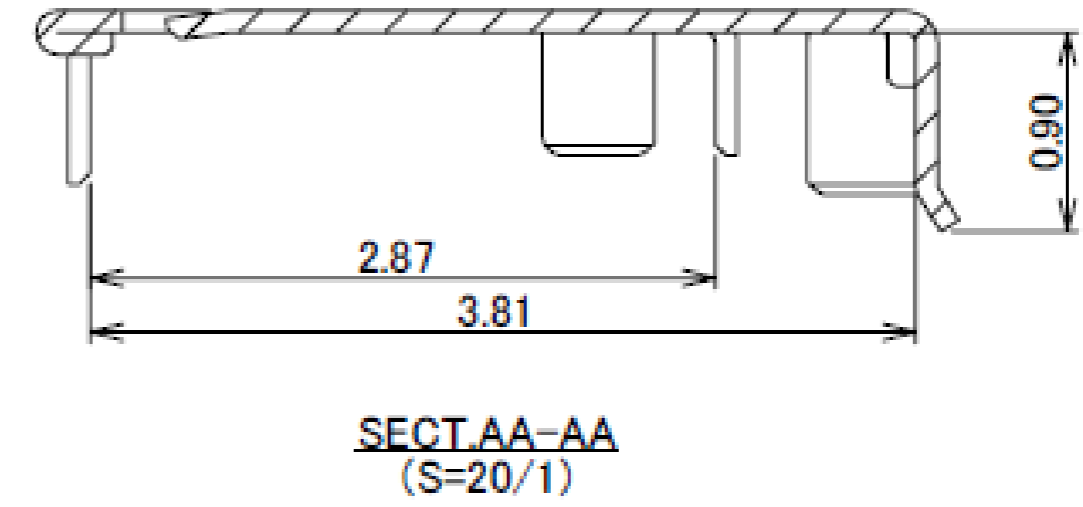
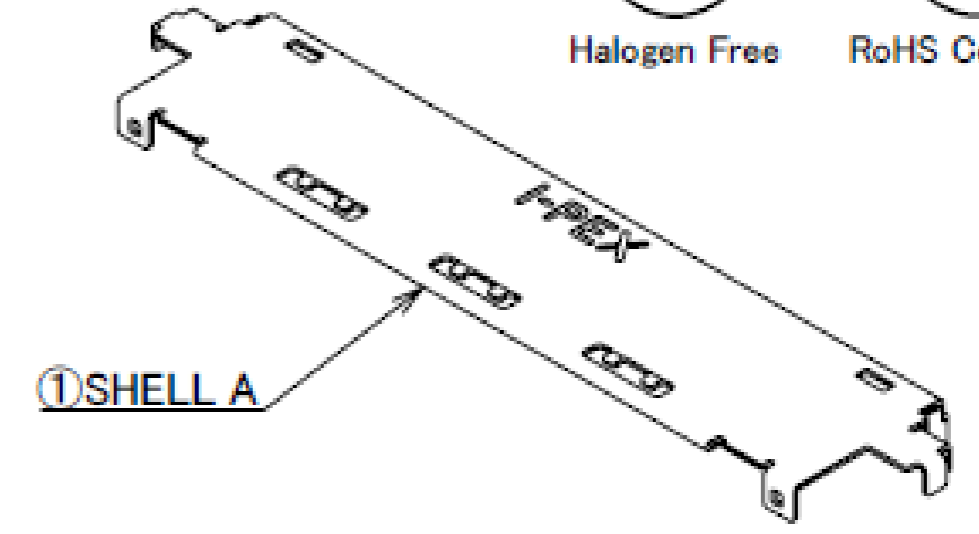
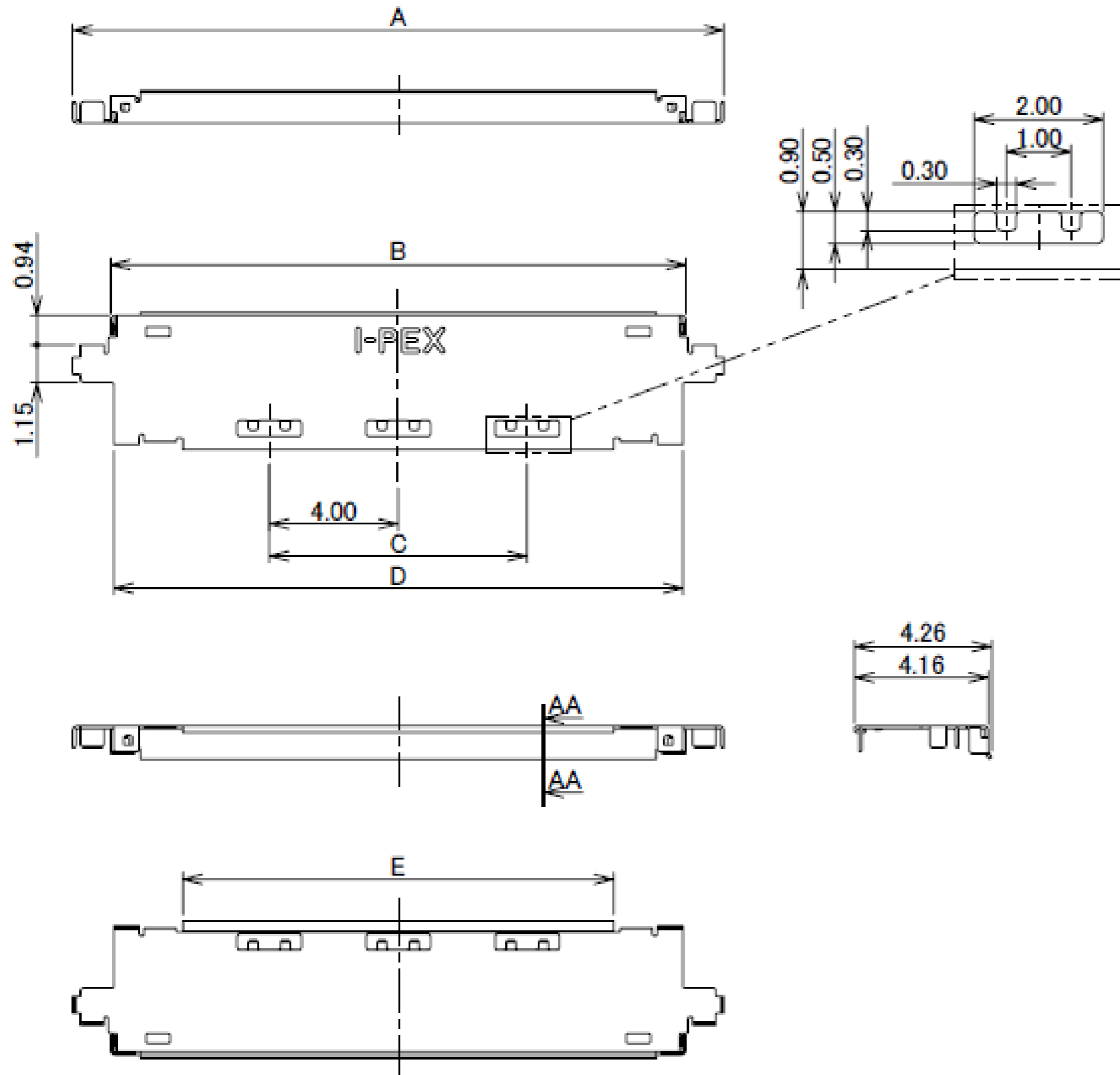

NO.	DISCRIPTION	MATERIAL	FINISH , REMARKS
1	SHELL A	PHOSPHOR BRONZE	PARTIAL Au 0.003 $\mu$ m MIN. OVER Ni 1.00 $\mu$ m MIN.

Rev.5

# Plug Pull Tape Holder

Recommended P/N		3588-0**1		
PART NO.	Pos.	A	B	C
3588-0301	30	10.00	15.65	13.65
3588-0401	40	14.00	19.65	17.65
3588-0501	50	18.00	23.65	21.65
3588-0601	60	22.00	27.65	25.65
3588-0701	70	26.00	31.65	29.65

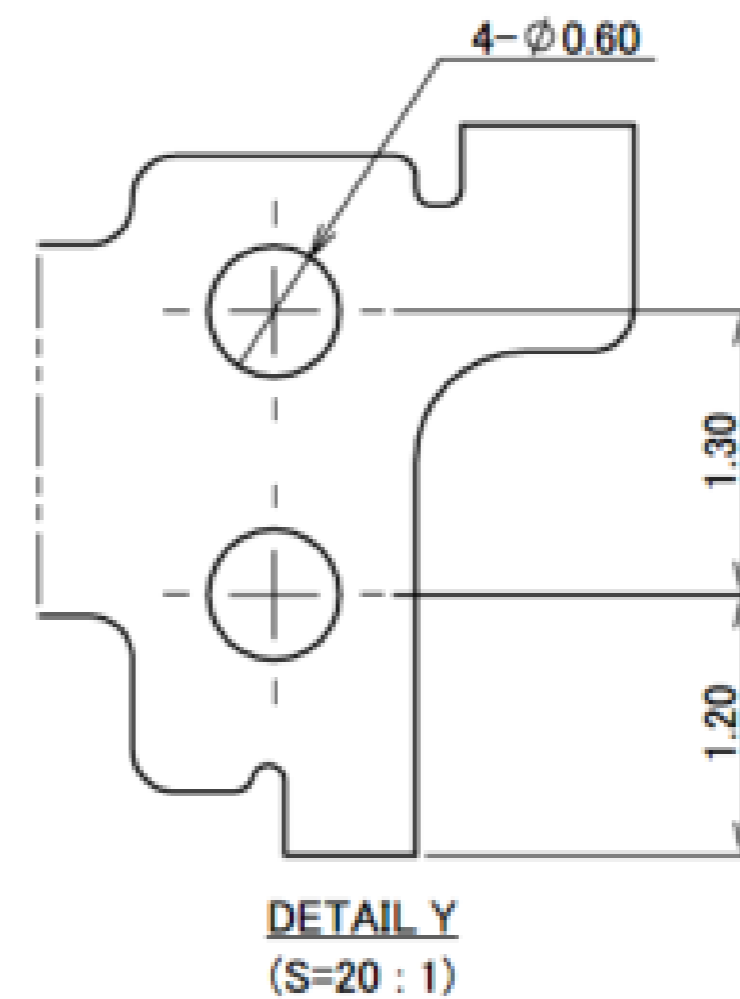
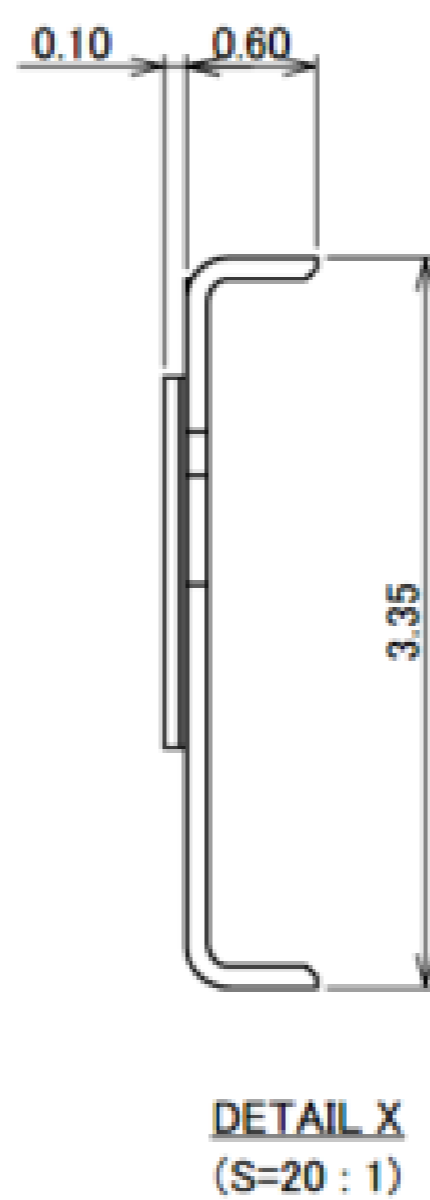
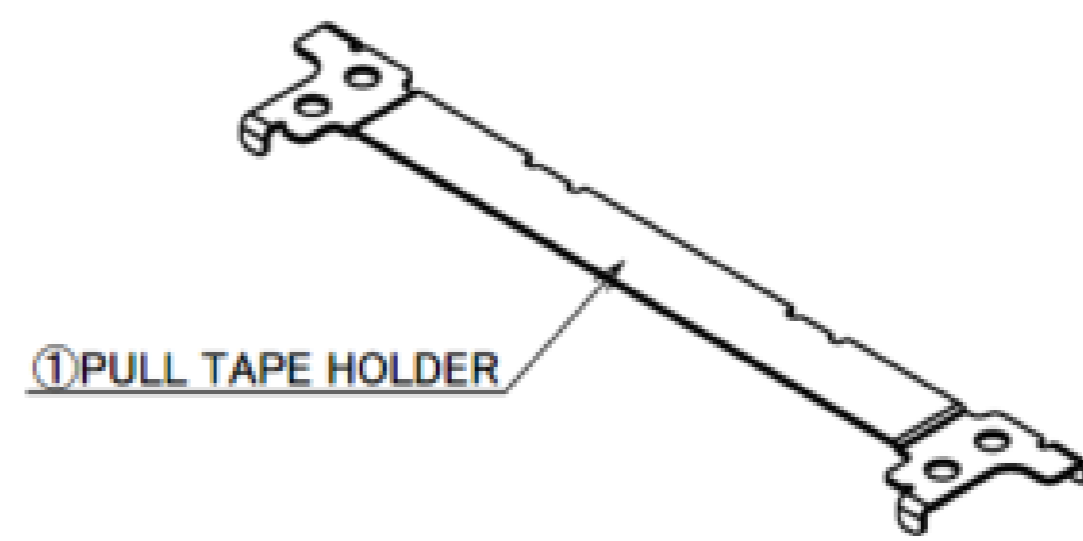
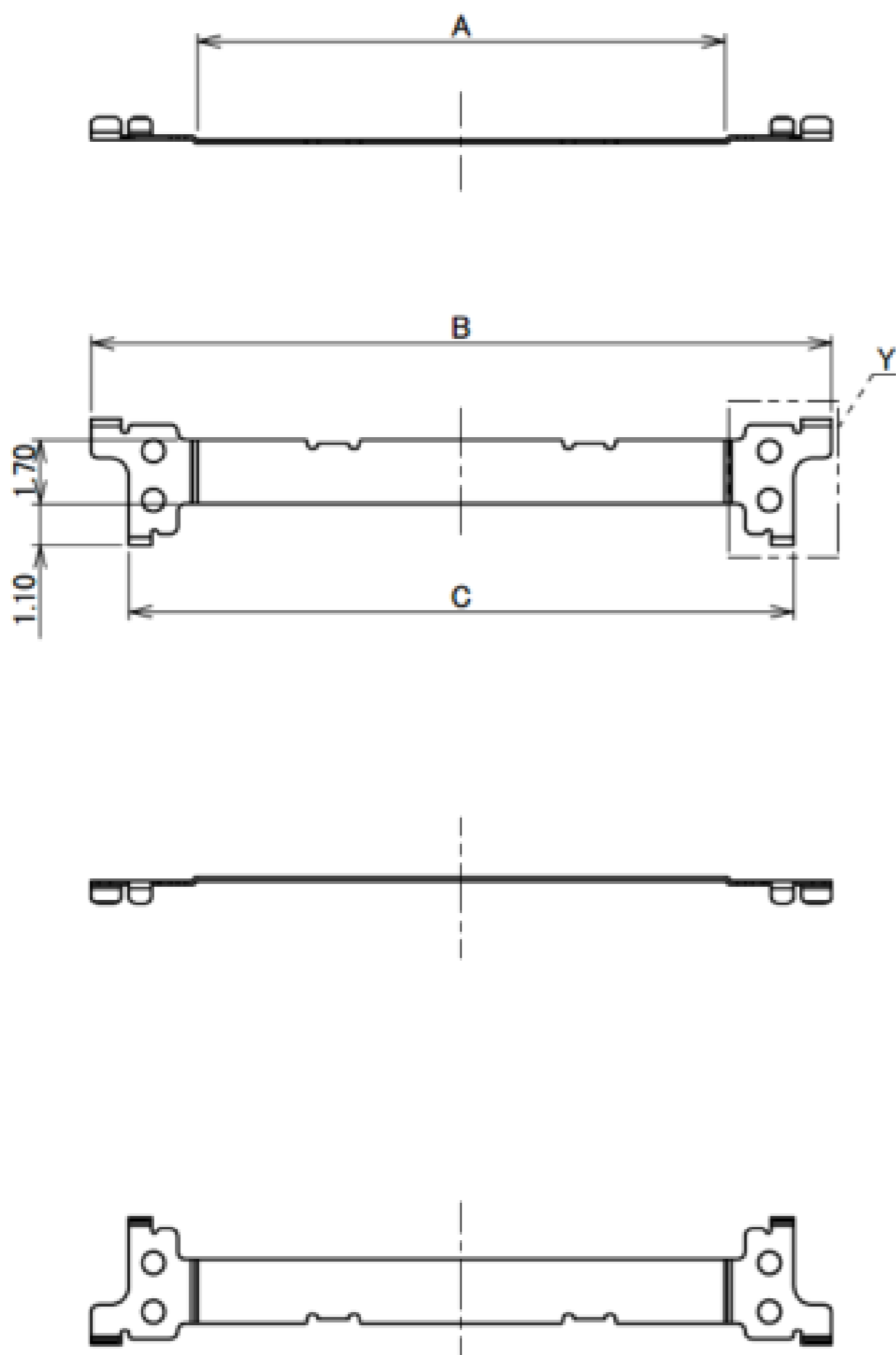

NO.	DISCRIPTION	MATERIAL	FINISH , REMARKS
1	PULL TAPE HOLDER	PHOSPHOR BRONZE	PARTIAL Au 0.003 $\mu$ m MIN. OVER Ni 1.00 $\mu$ m MIN.

Rev.5

# Lock Cover

Recommended P/N		3493-0**1			
PART NO.	Pos.	A	B	C	D
3493-0301	30	17.00	14.05	12.40	15.30
3493-0401	40	21.00	18.05	16.40	19.30
3493-0501	50	25.00	22.05	20.40	23.30
3493-0601	60	29.00	26.05	24.40	27.30
3493-0701	70	33.00	30.05	28.40	31.30

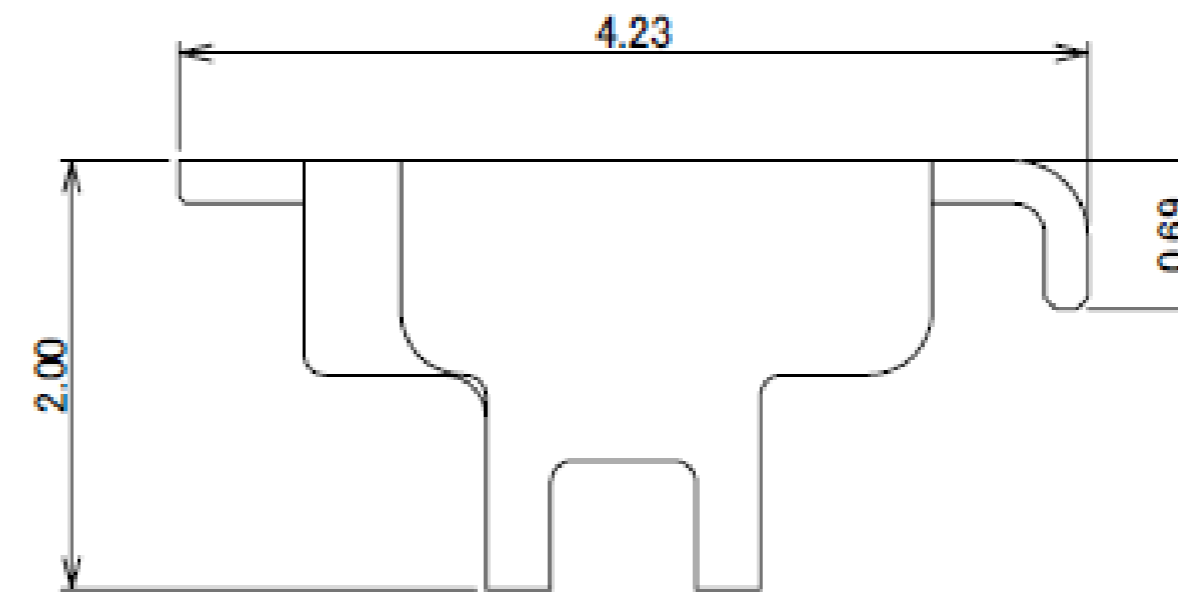
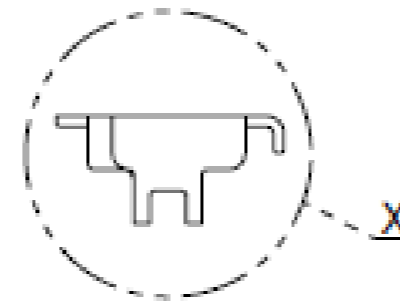
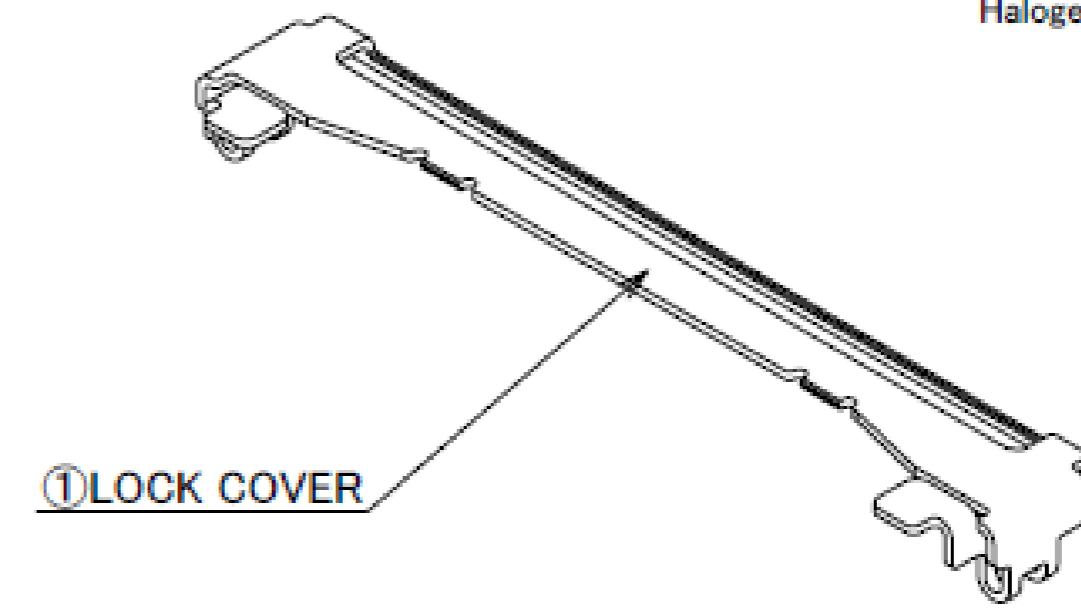
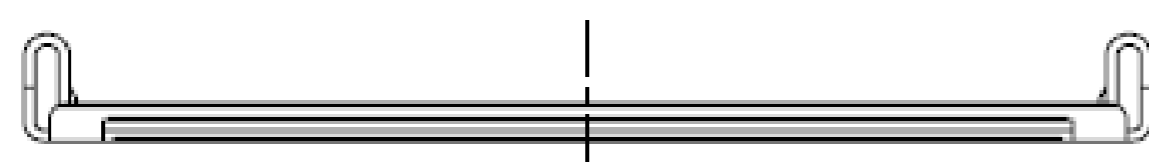
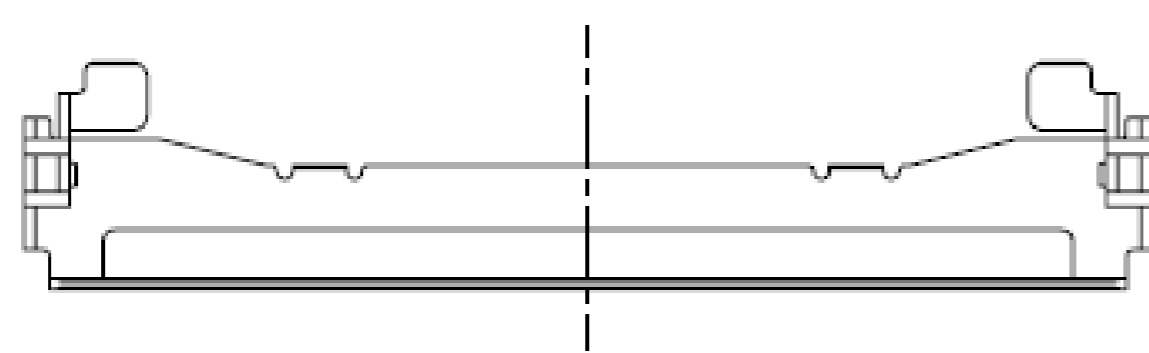
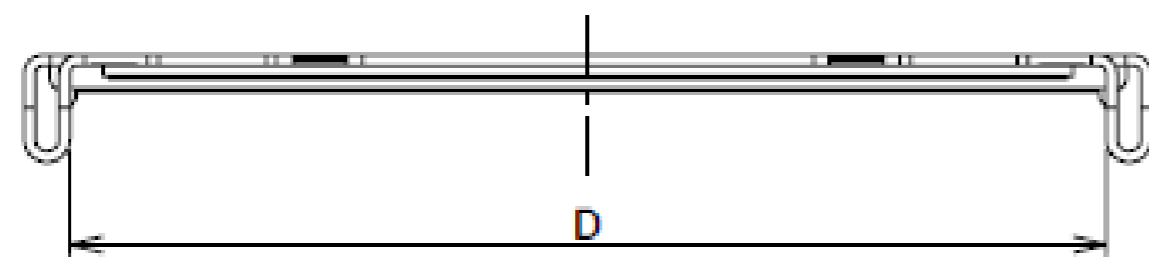
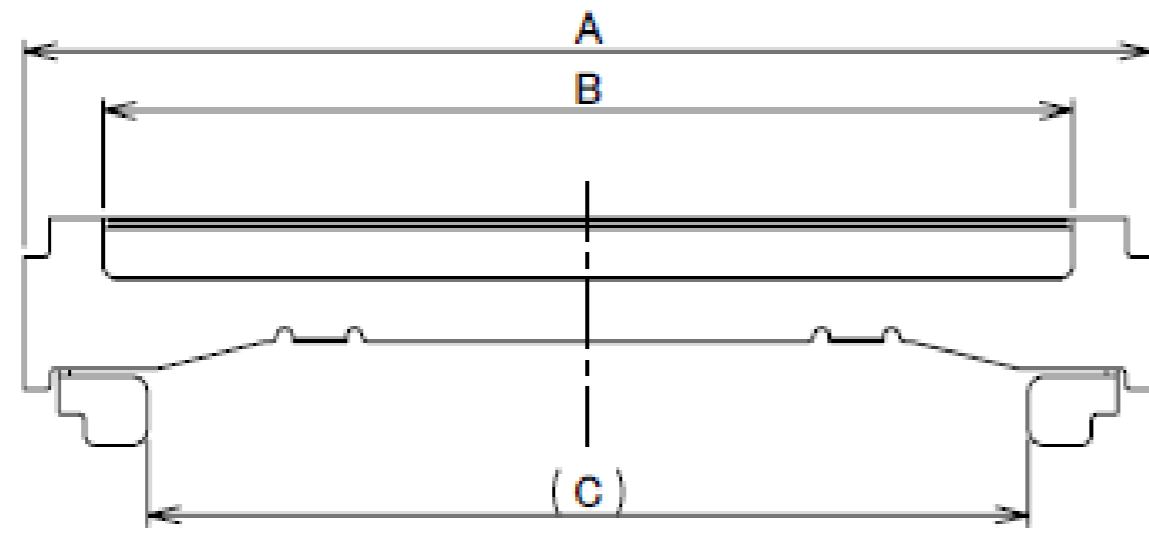

DETAIL X  
(S=20 : 1)

NO.	DISCRIPTION	MATERIAL	FINISH , REMARKS
1	LOCK COVER	PHOSPHOR BRONZE	ALL OVER Ni 1.00 μm MIN.

Rev.5

# Receptacle Assembly

Recommended P/N		20879-0**E-01							
PART NO.	Pos.	A	B	C	D	E	F	G	H
20879-030E-#1	30	15.27	13.01	11.60	9.60	12.07	12.88	15.27	13.65
20879-040E-#1	40	19.27	17.01	15.60	14.40	16.07	16.88	19.27	17.65
20879-050E-#1	50	23.27	21.01	19.60	17.60	20.07	20.88	23.27	21.65
20879-060E-#1	60	27.27	25.01	23.60	21.60	24.07	24.88	27.27	25.65

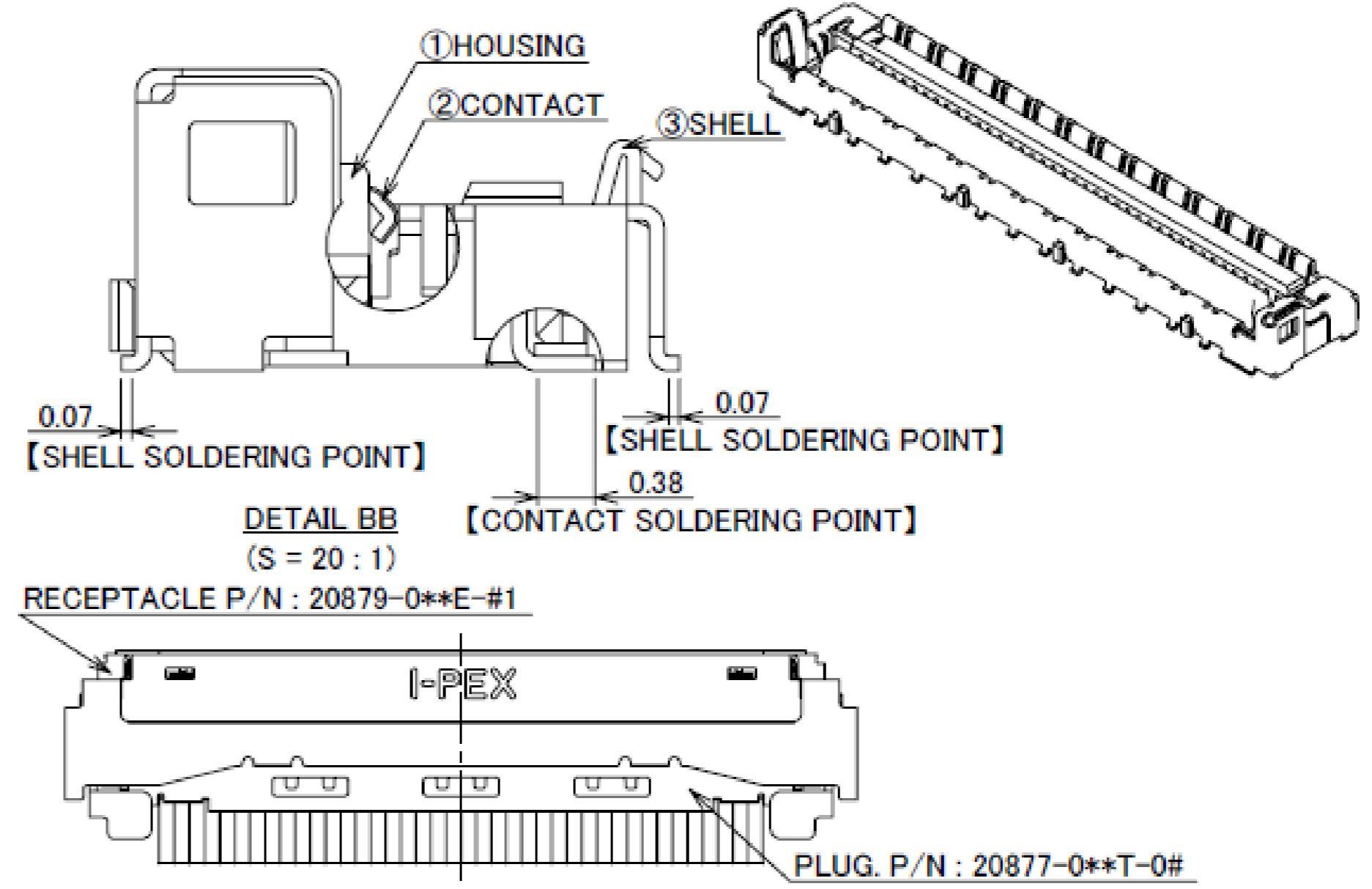
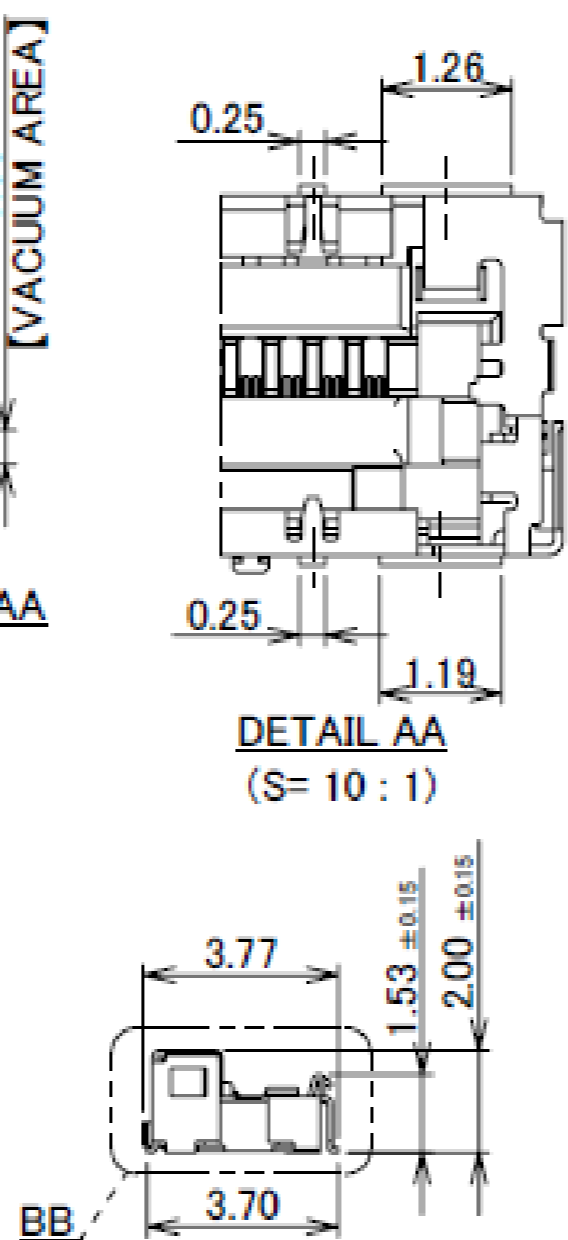
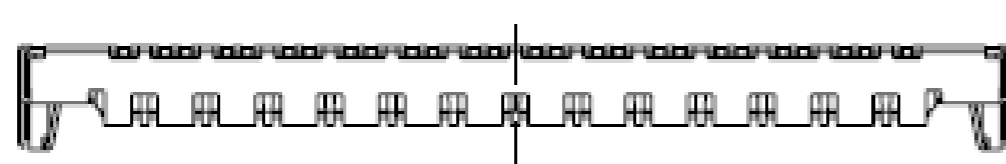
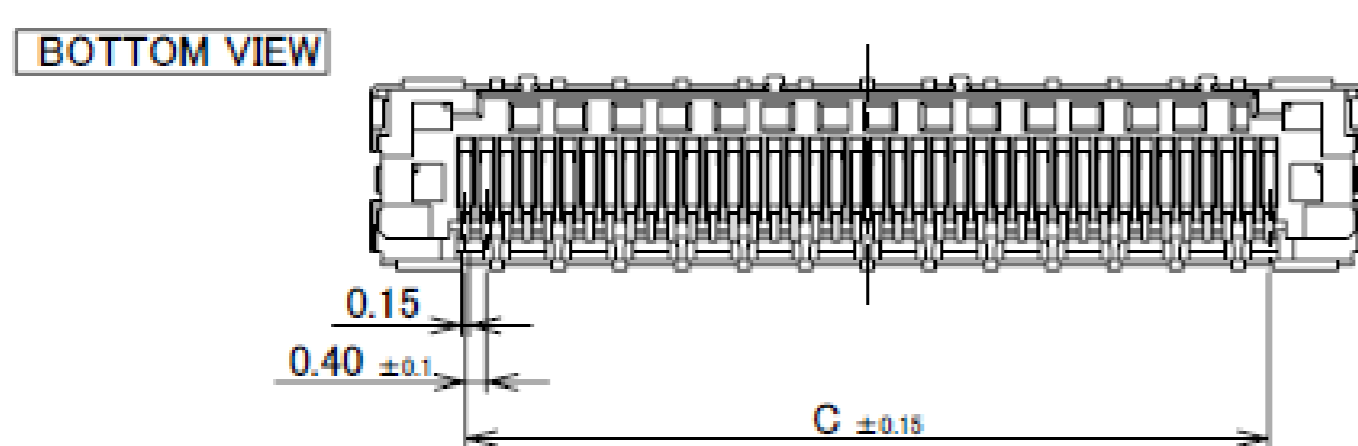
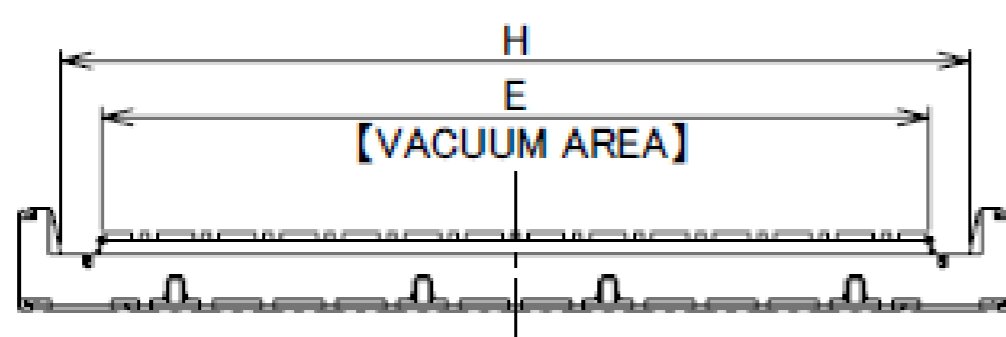
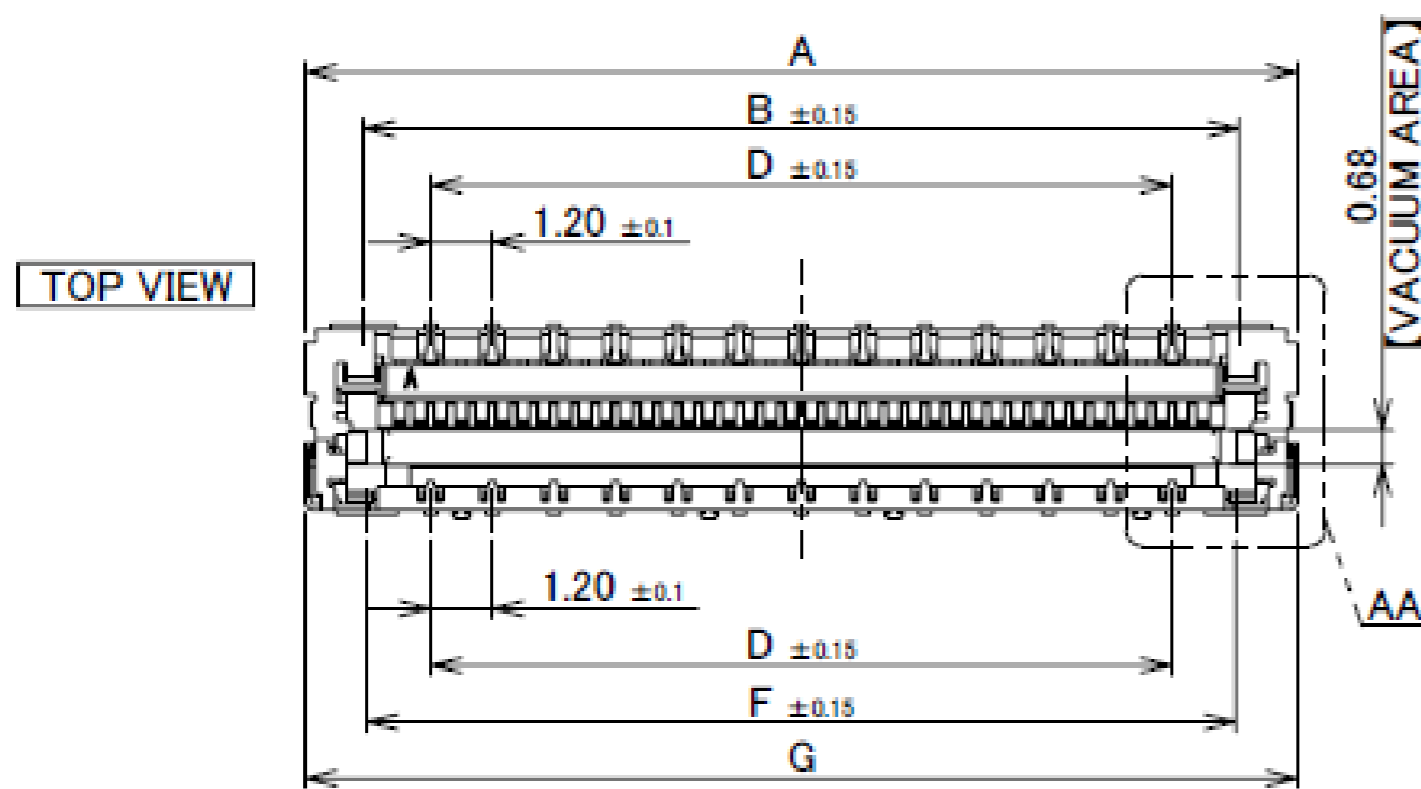
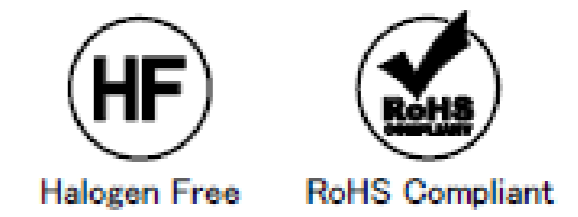
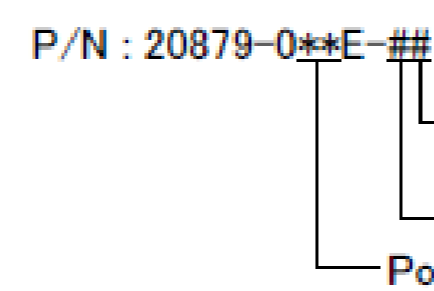

MATING CONDITION

TABLE.1

PART NO.	CONTACT FINISH
20879-0**E-01	ALL OVER Ni 1.00 μm MIN. CONTACT & SOLDERING AREA : Au 0.03 μm MIN.
20879-0**E-11	ALL OVER Ni 1.27 μm MIN. CONTACT AREA : Au 0.254 μm MIN. SOLDERING AREA : Au 0.03 μm MIN.

NO.	DISCRIPTION	MATERIAL	FINISH , REMARKS
3	SHELL	PHOSPHOR BRONZE	ALL OVER : Ni 1.00 μm MIN. SOLDERING AREA : Au 0.02 μm MIN.
2	CONTACT	CORSON ALLOY	SEE TABLE.1
1	HOUSING	LCP	UL94V-0, BLACK

Rev.18

# Receptacle Assembly

Recommended P/N		20879-0**E-01		
PART NO.	Pos.	A	D	G
20879-030E-#1	30	15.27	9.60	15.27
20879-040E-#1	40	19.27	14.40	19.27
20879-050E-#1	50	23.27	17.60	23.27
20879-060E-#1	60	27.27	21.60	27.27

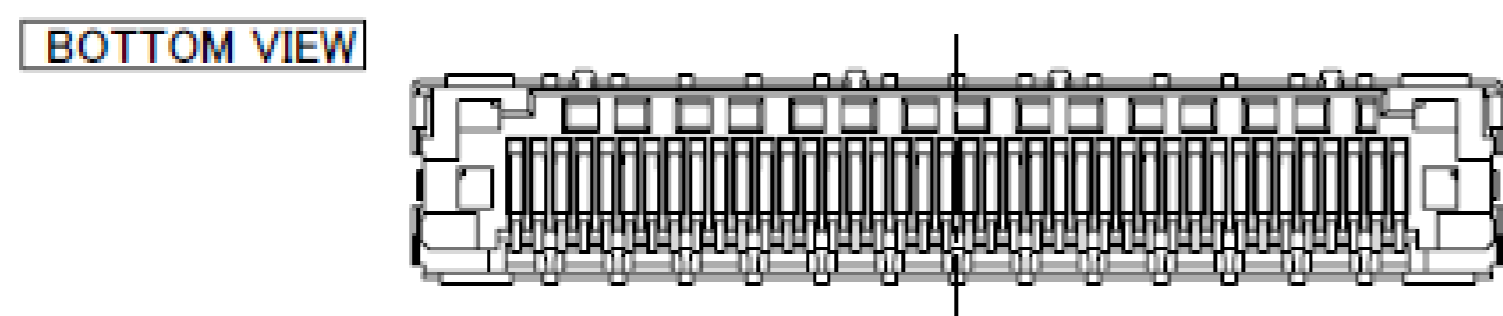
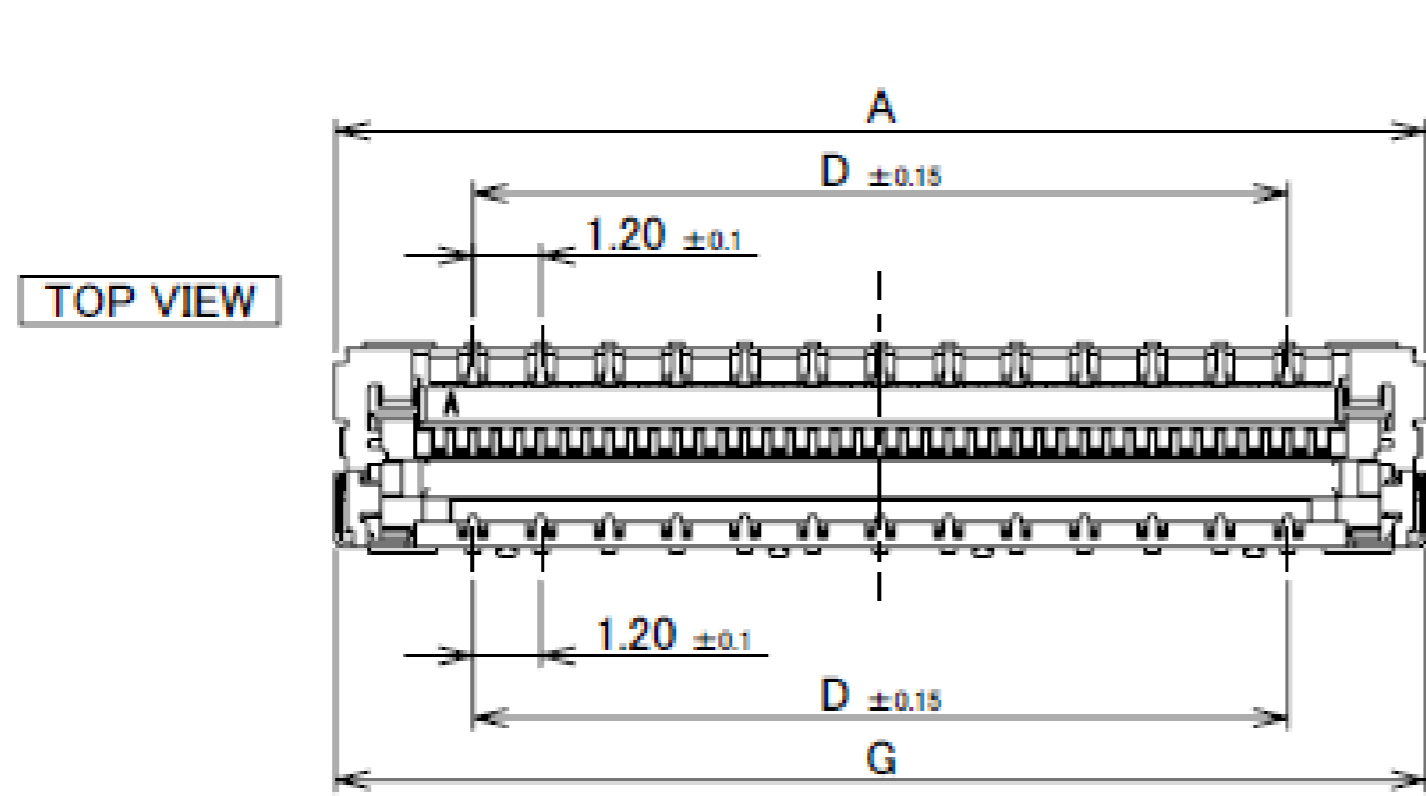

30P, 40P, 60P

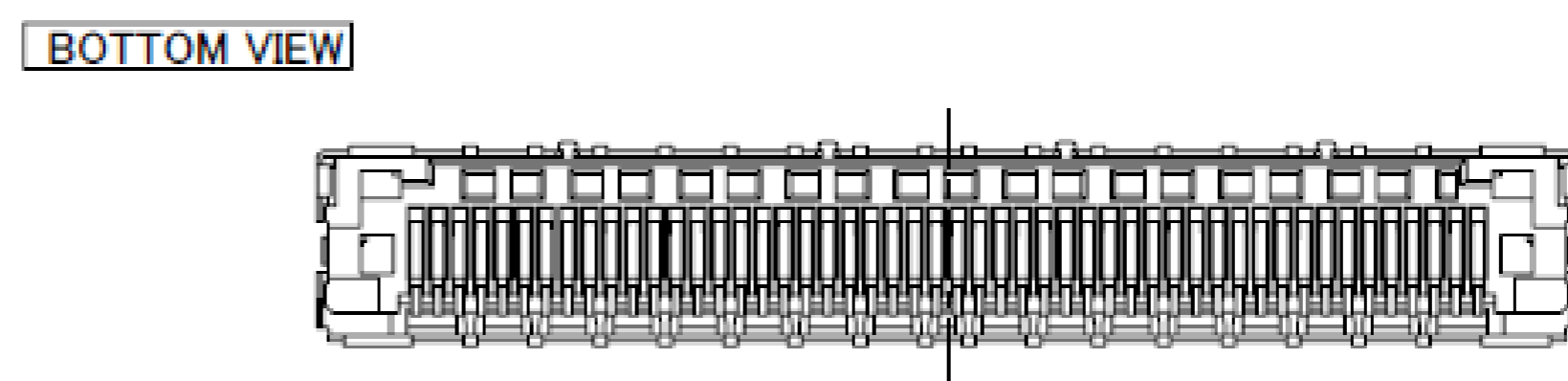
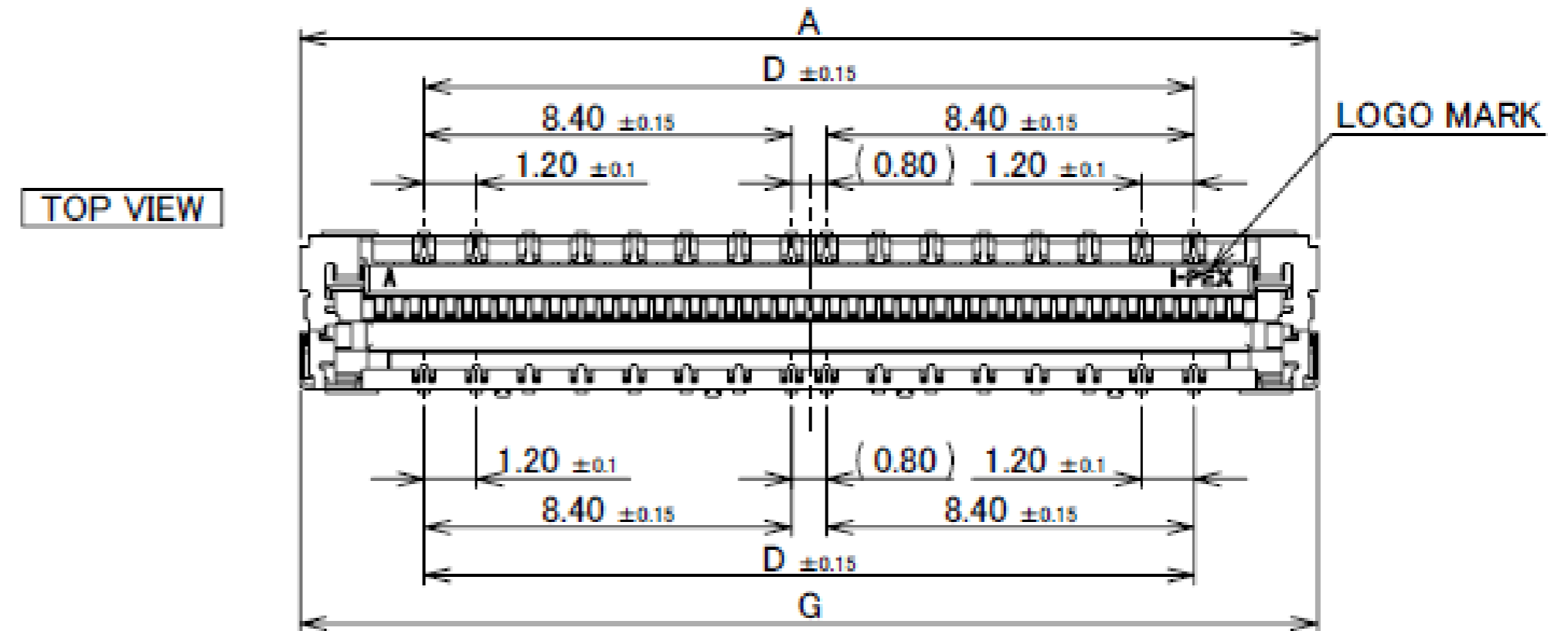

50P

Rev.18

Recommended P/N		20879-0**E-01									
PART NO.	Pos.	A	C	E	G	H	J	K	L	M	N
20879-030E-02	30	15.27	11.60	12.07	15.27	13.65	14.87	4.00	-	7.09	14.69
20879-040E-02	40	19.27	15.60	16.07	19.27	17.65	18.87	8.00	4.00	6.70	18.69
20879-050E-02	50	23.27	19.60	20.07	23.27	21.65	22.87	14.40	3.60	8.70	22.69
20879-060E-02	60	27.27	23.60	24.07	27.27	25.65	26.87	17.60	-	10.70	26.69
20879-070E-02	70	31.27	27.60	28.07	31.27	29.65	30.87	20.00	-	11.50	30.69

02 TYPE

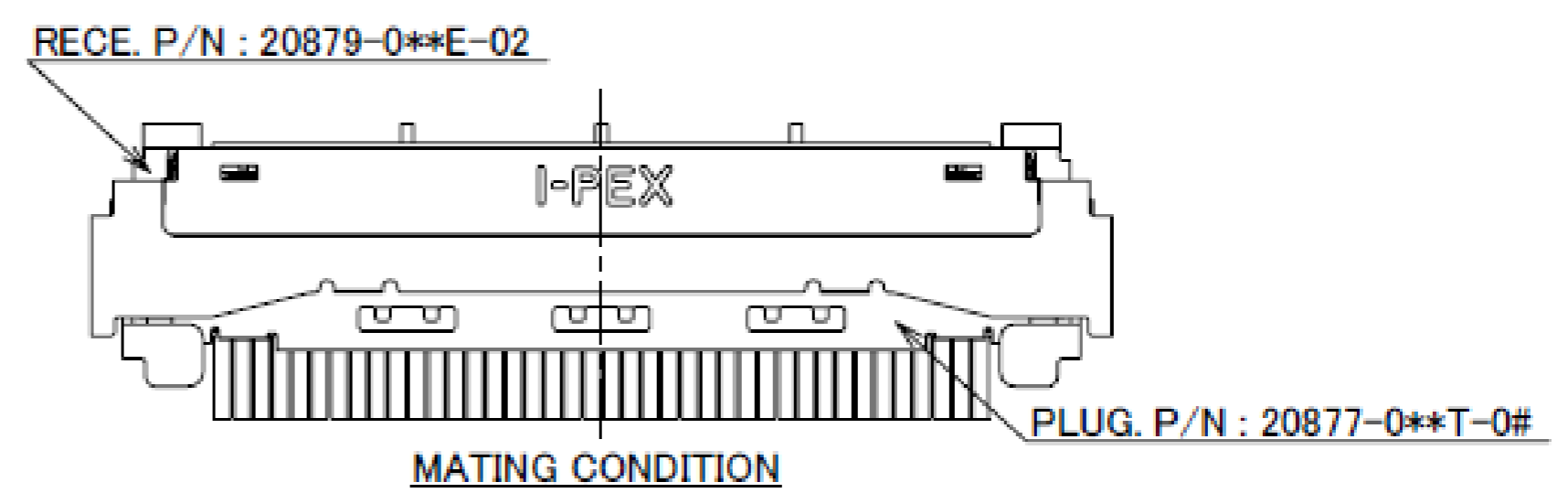
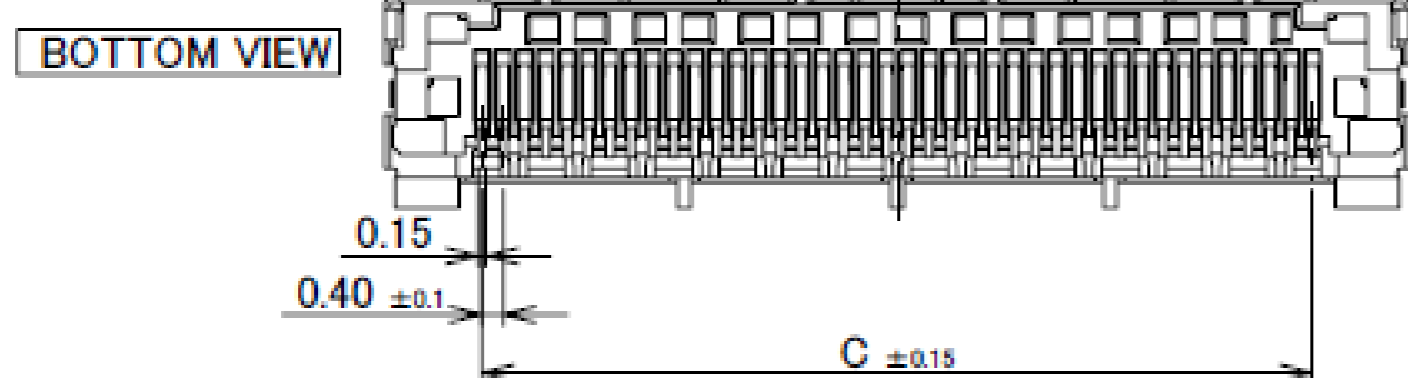
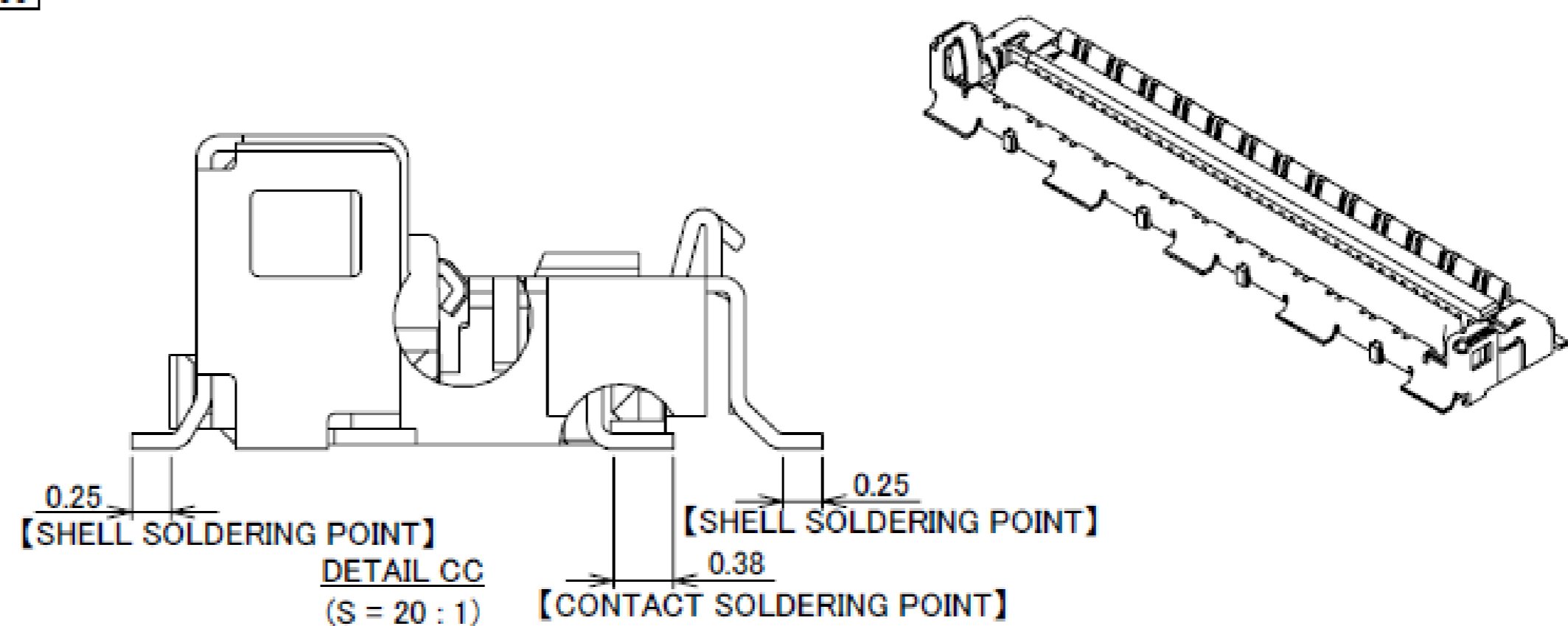
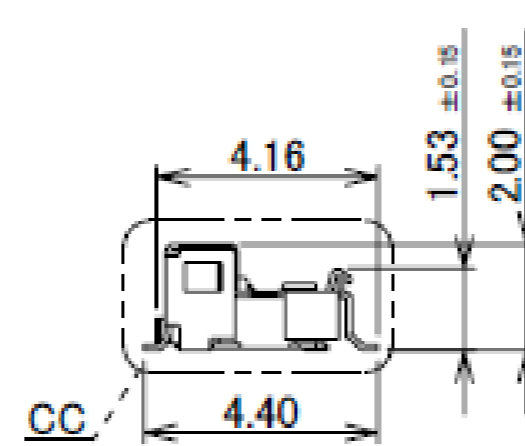
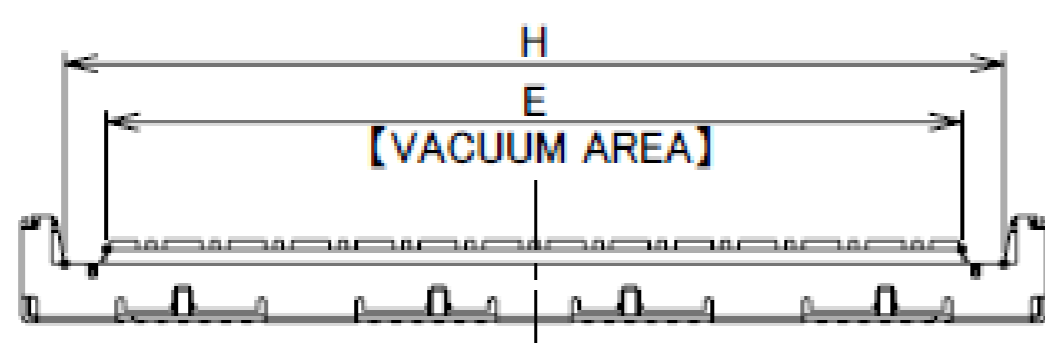
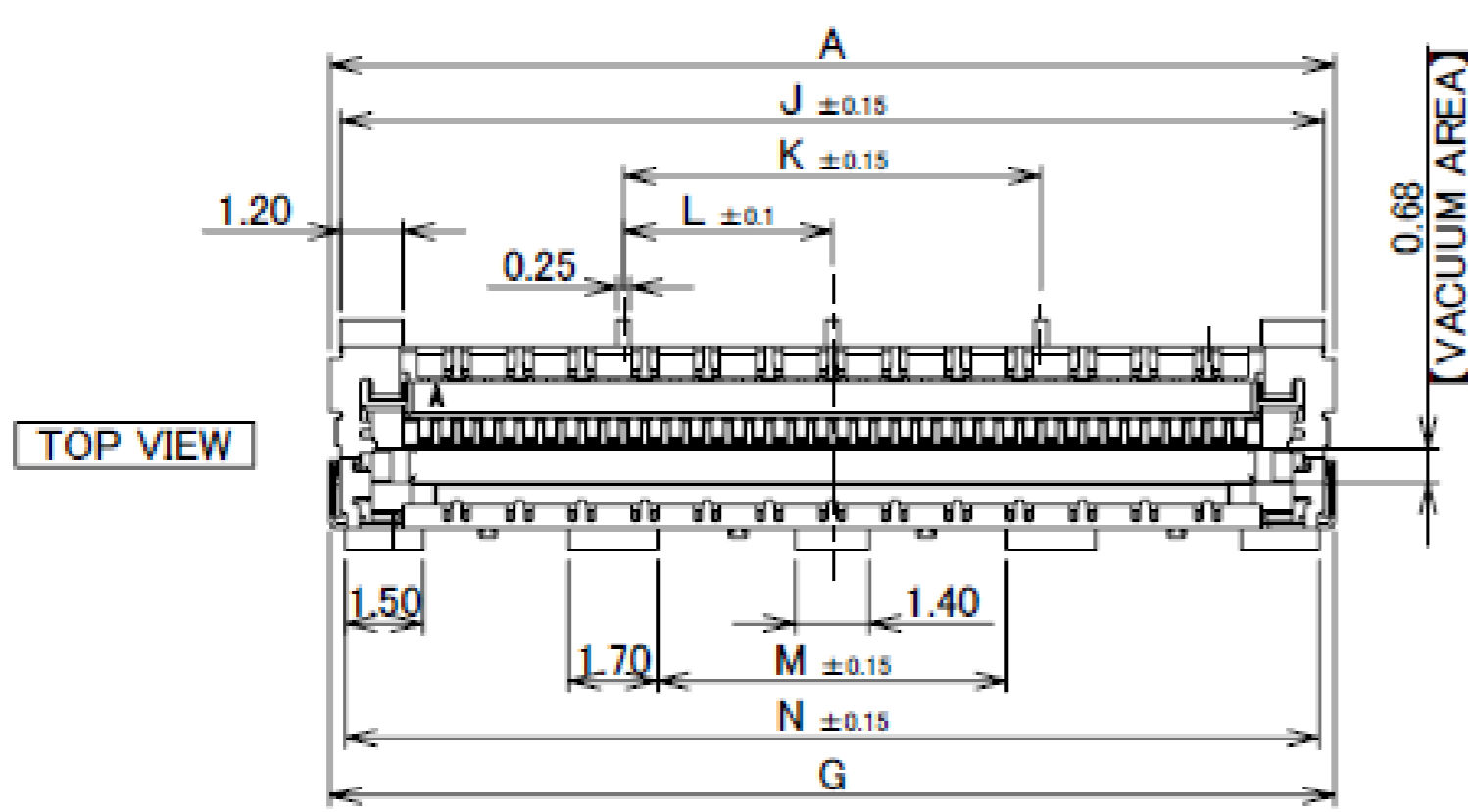

Rev.18

# Receptacle Assembly

Recommended P/N 20879-0\*\*E-01

PART NO.	Pos.	A	C	E	G	H	J	K	L	M	N	P	AD
20879-030E-02	30	15.27	11.60	12.07	15.27	13.65	14.87	4.00	-	7.09	14.69	-	-
20879-040E-02	40	19.27	15.60	16.07	19.27	17.65	18.87	8.00	4.00	6.70	18.69	-	-
20879-050E-02	50	23.27	19.60	20.07	23.27	21.65	22.87	14.40	3.60	8.70	22.69	7.20	-
20879-060E-02	60	27.27	23.60	24.07	27.27	25.65	26.87	17.60	-	10.70	26.69	11.20	3.20
20879-070E-02	70	31.27	27.60	28.07	31.27	29.65	30.87	20.00	-	11.50	30.69	12.00	4.00

02 TYPE

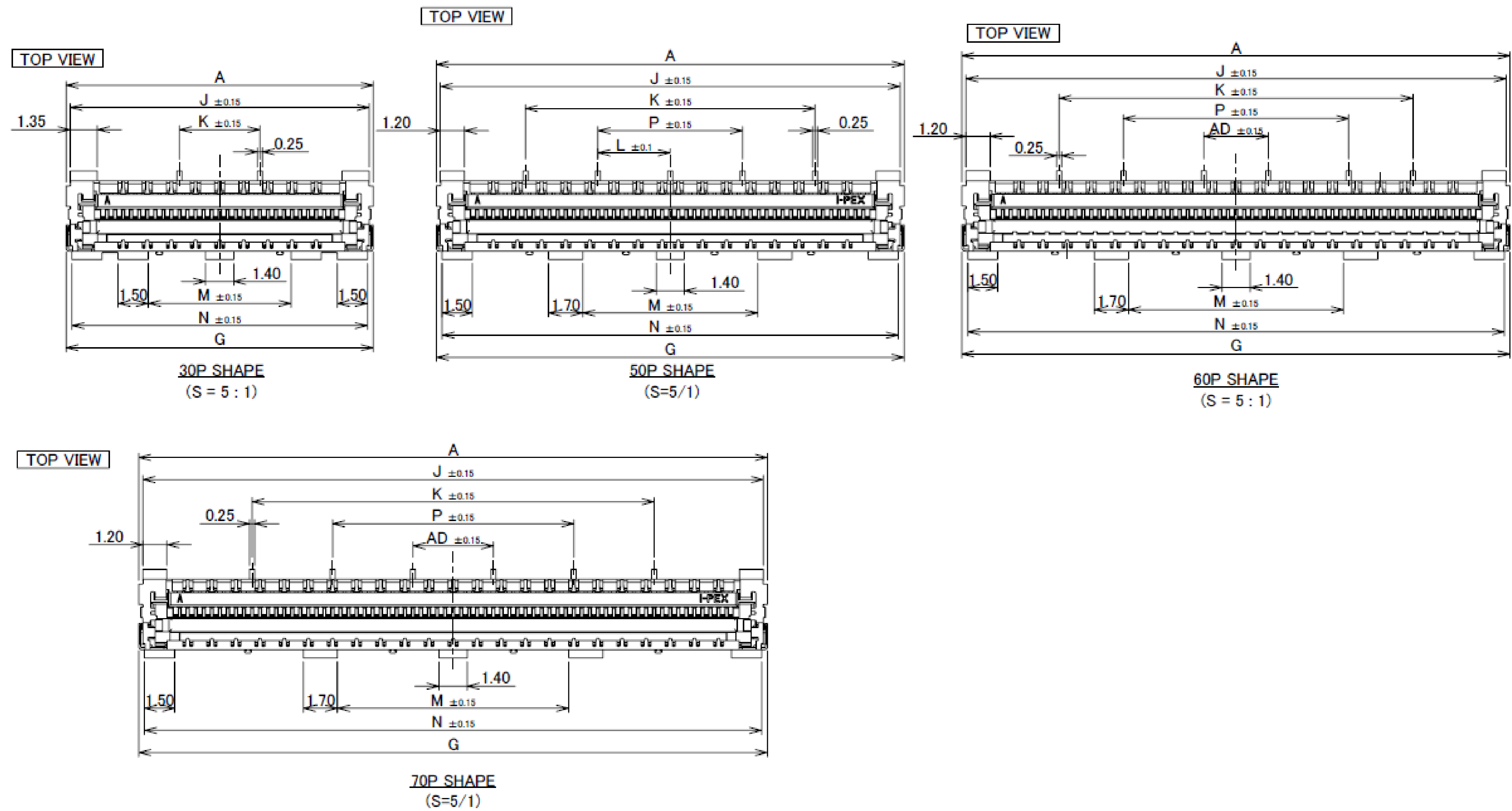
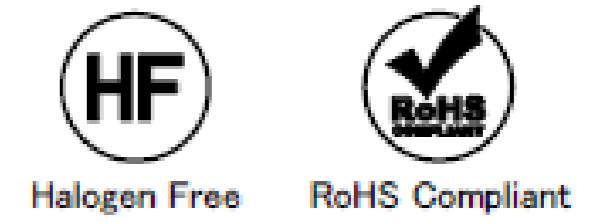

Rev.18

PART No.	Pos.	B	C	D	F	P	Q	R	S	T	AE	AF
20879-030E-#1	30	13.01	11.60	9.60	12.88	15.17	12.00	15.07	19.00	12.50	18.00	17.00
20879-040E-#1	40	17.01	15.60	14.40	16.88	19.17	16.00	19.07	23.00	16.50	22.00	21.00
20879-060E-#1	60	25.01	23.60	21.60	24.88	27.17	24.00	27.07	31.00	24.50	30.00	29.00

PLUG PART No.	DUAL-HOOK PULL JIG	PCB LAYOUT
20877-0##T-01	USE	TYPE A
	UNUSED	TYPE B
20877-0##T-02	USE	TYPE A
	UNUSED	TYPE C
20877-0##T-03	-	TYPE C
	-	

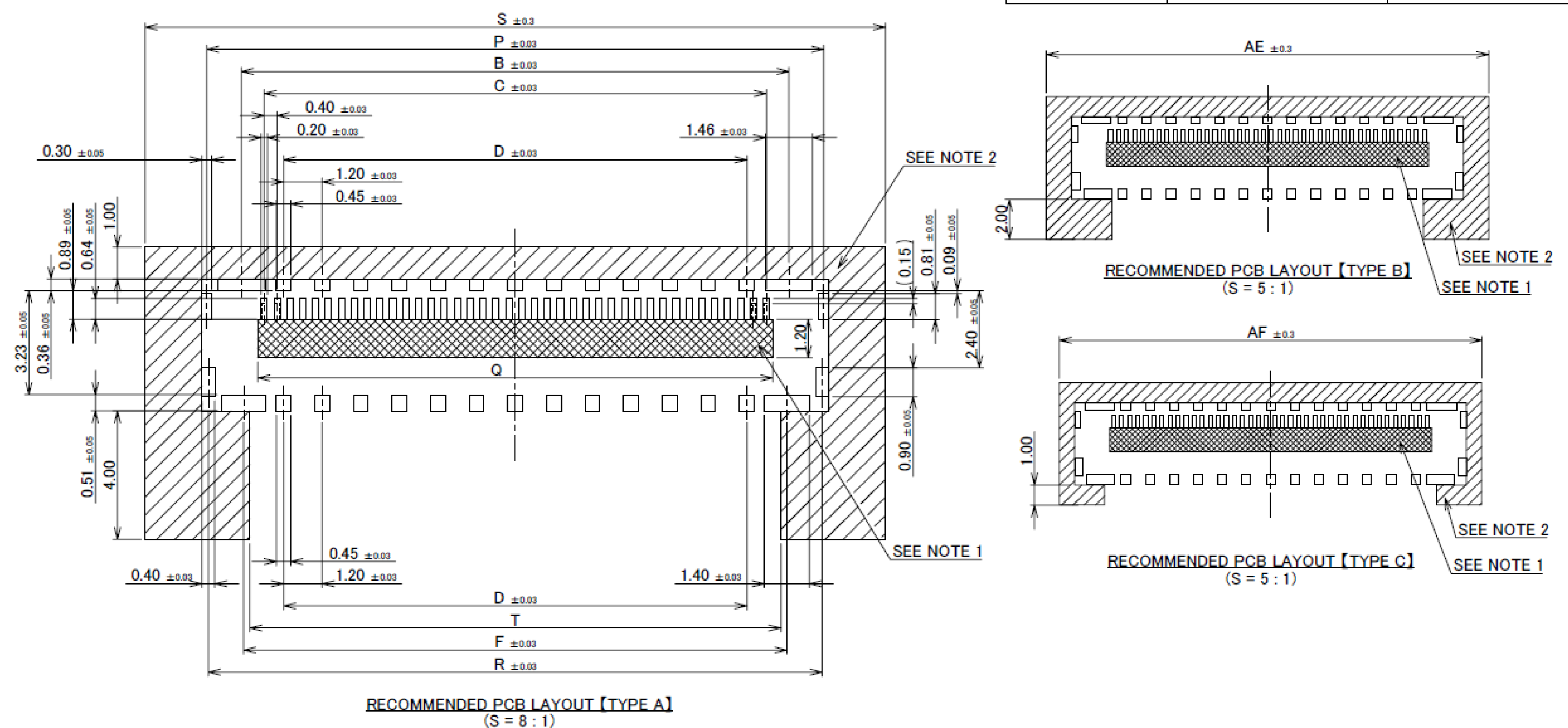

NOTES.

- SOLDER RESIST MUST BE APPLIED TO THIS AREA.
  - DO NOT MOUNT ANOTHER COMPONENT IN THIS AREA.
- THIS AREA VARIES DEPENDING ON WHETHER THE PULL JIG IS USED, AND THE PART NUMBER OF THE PLUG CABLE ASSEMBLY BEING USED. FOR DETAILS ON THE PULL JIG, PLEASE REFER TO HIM-18033.

Rev.18

# Receptacle Assembly

PART No.	Pos.	B	C	D	F	P	Q	R	S	T	AE	AF
20879-050E-#1	50	21.01	19.60	17.60	20.88	23.17	20.00	23.07	27.00	20.50	26.00	25.00

PLUG PART No.	DUAL-HOOK PULL JIG	PCB LAYOUT
20877-0##T-01	USE	TYPE A
	UNUSED	TYPE B
20877-0##T-02	USE	TYPE A
	UNUSED	TYPE C
20877-0##T-03	-	TYPE C
	-	

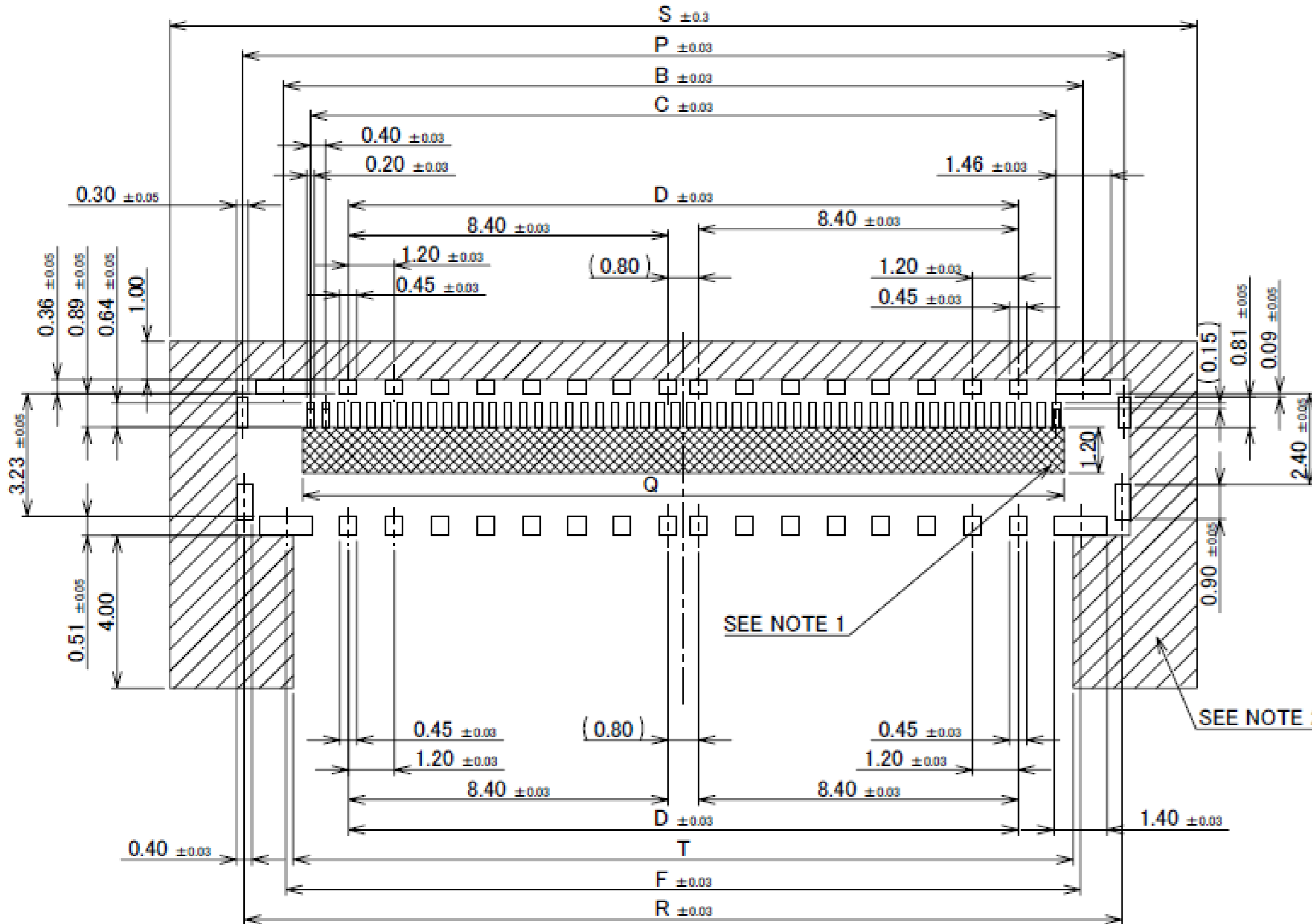

50P RECOMMENDED PCB LAYOUT [TYPE A]  
(S=7/1)

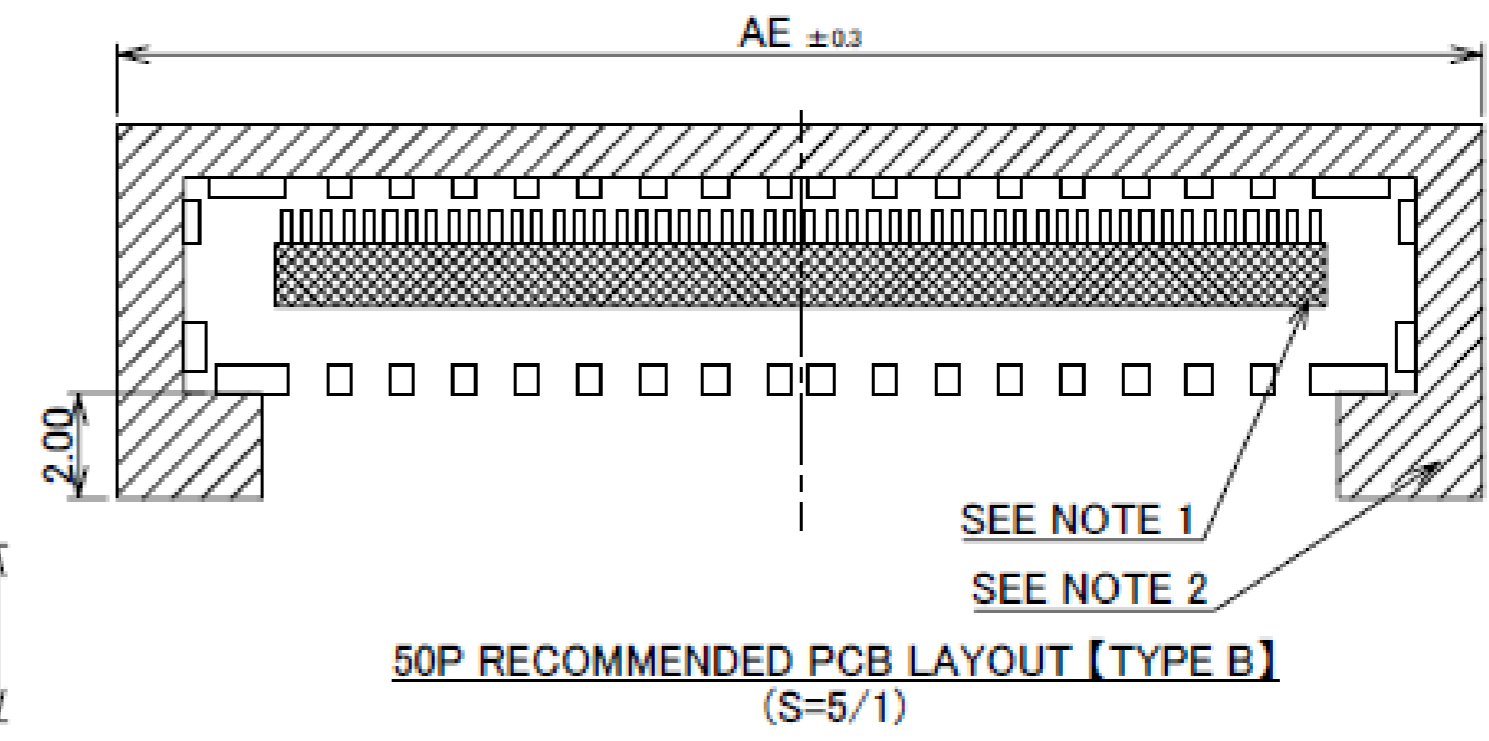

50P RECOMMENDED PCB LAYOUT [TYPE B]  
(S=5/1)

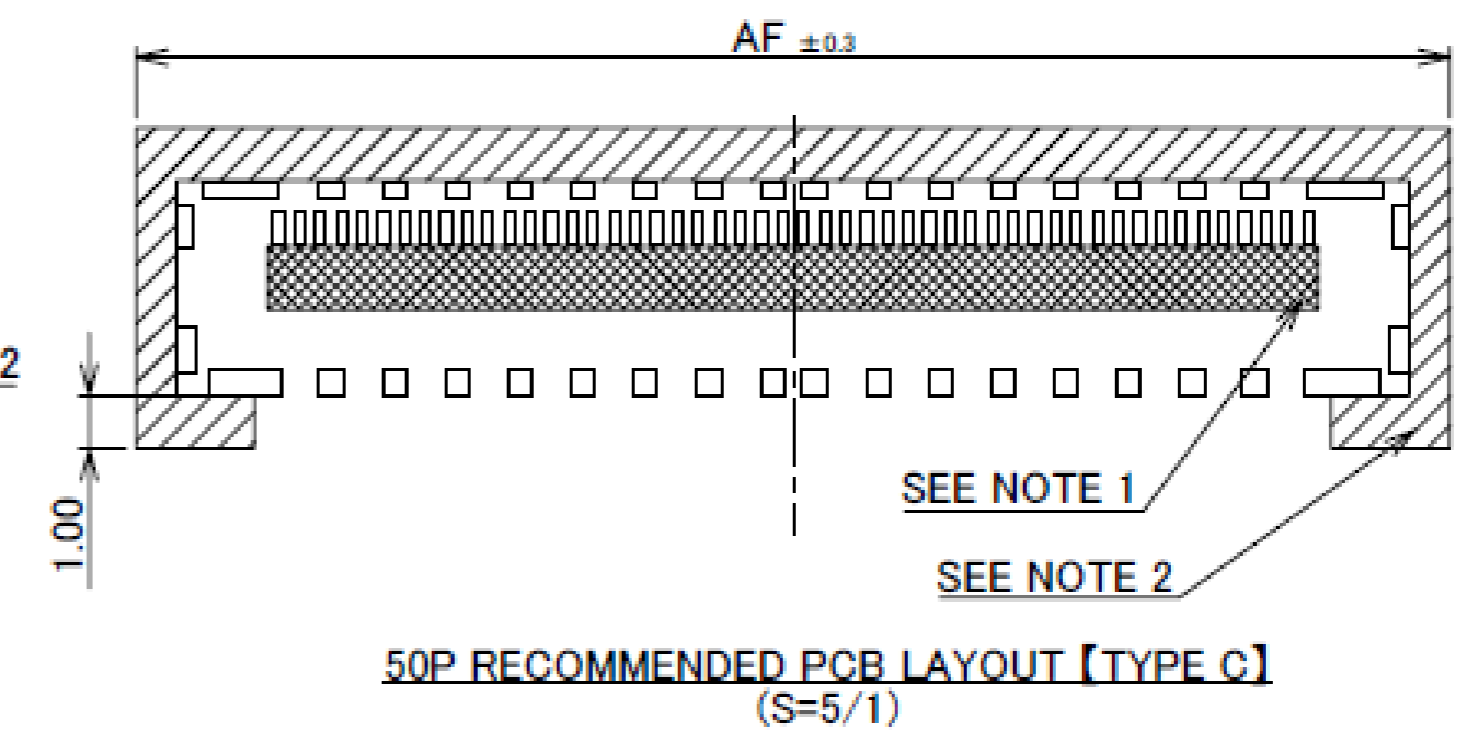

50P RECOMMENDED PCB LAYOUT [TYPE C]  
(S=5/1)

**NOTES.**

1. SOLDER RESIST MUST BE APPLIED TO THIS AREA.
  2. DO NOT MOUNT ANOTHER COMPONENT IN THIS AREA.
- THIS AREA VARIES DEPENDING ON WHETHER THE PULL JIG IS USED, AND THE PART NUMBER OF THE PLUG CABLE ASSEMBLY BEING USED. FOR DETAILS ON THE PULL JIG, PLEASE REFER TO HIM-18033.

Rev.18

PART No.	Pos.
20879-030E-#1	30
20879-040E-#1	40
20879-050E-#1	50
20879-060E-#1	60

**#1 TYPE**

**With LOCK COVER**

**Without LOCK COVER & With PULL TAPE HOLDER**

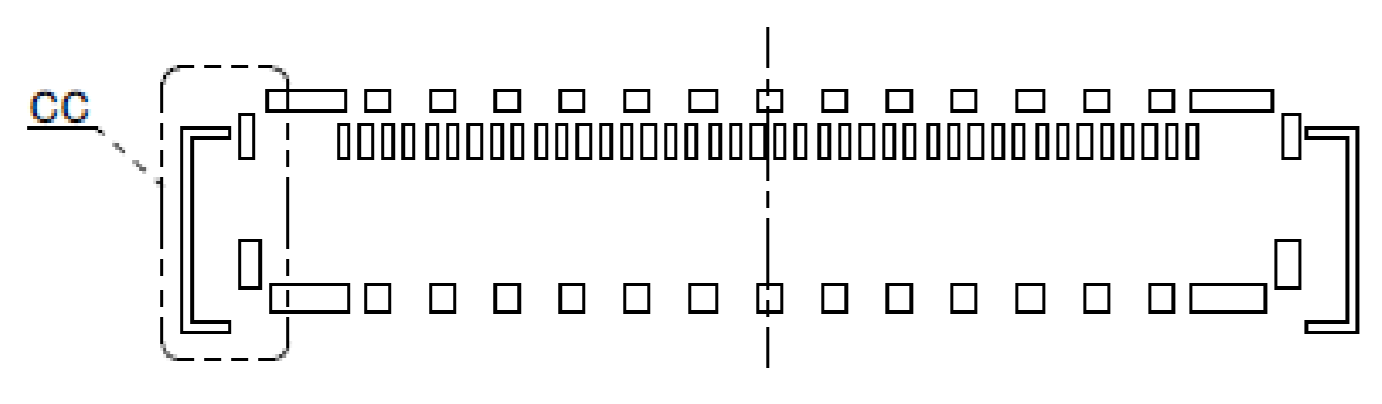

RECOMMENDED SILK PRINT For With LOCK COVER  
(S = 5 : 1)

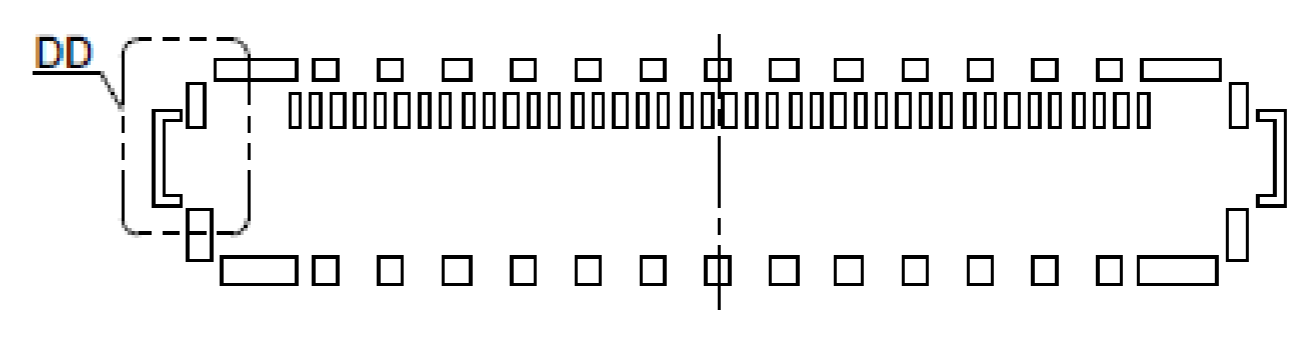

RECOMMENDED SILK PRINT For Without LOCK COVER  
(S = 5 : 1)

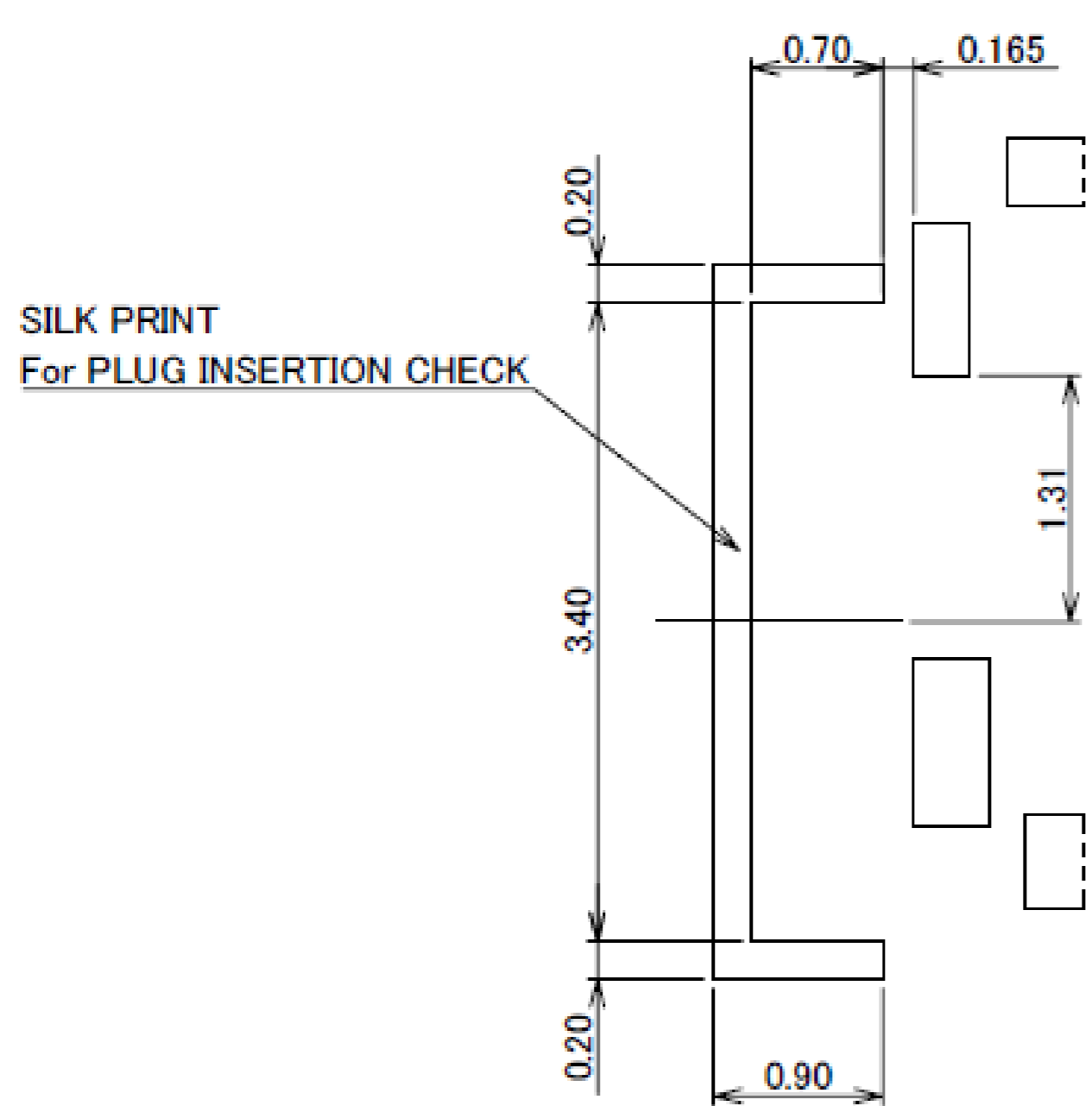

DETAIL CC  
(S = 20 : 1)

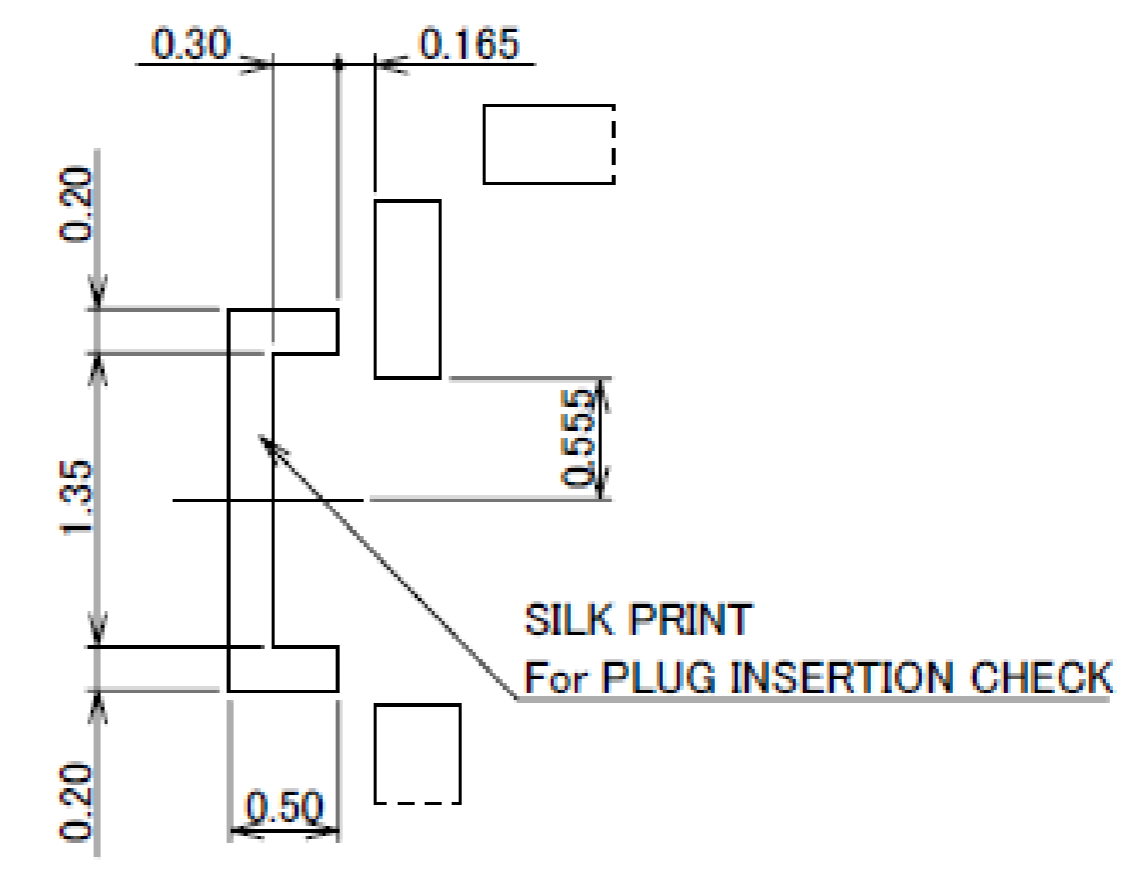

DETAIL DD  
(S = 20 : 1)

# Receptacle Assembly

PART No.	Pos.	C	K	L	Q	S	T	U	V	W	X	AE	AF
20879-030E-02	30	11.60	4.00	-	12.00	19.00	12.50	6.89	15.07	14.89	15.47	18.00	17.00

## 02 TYPE

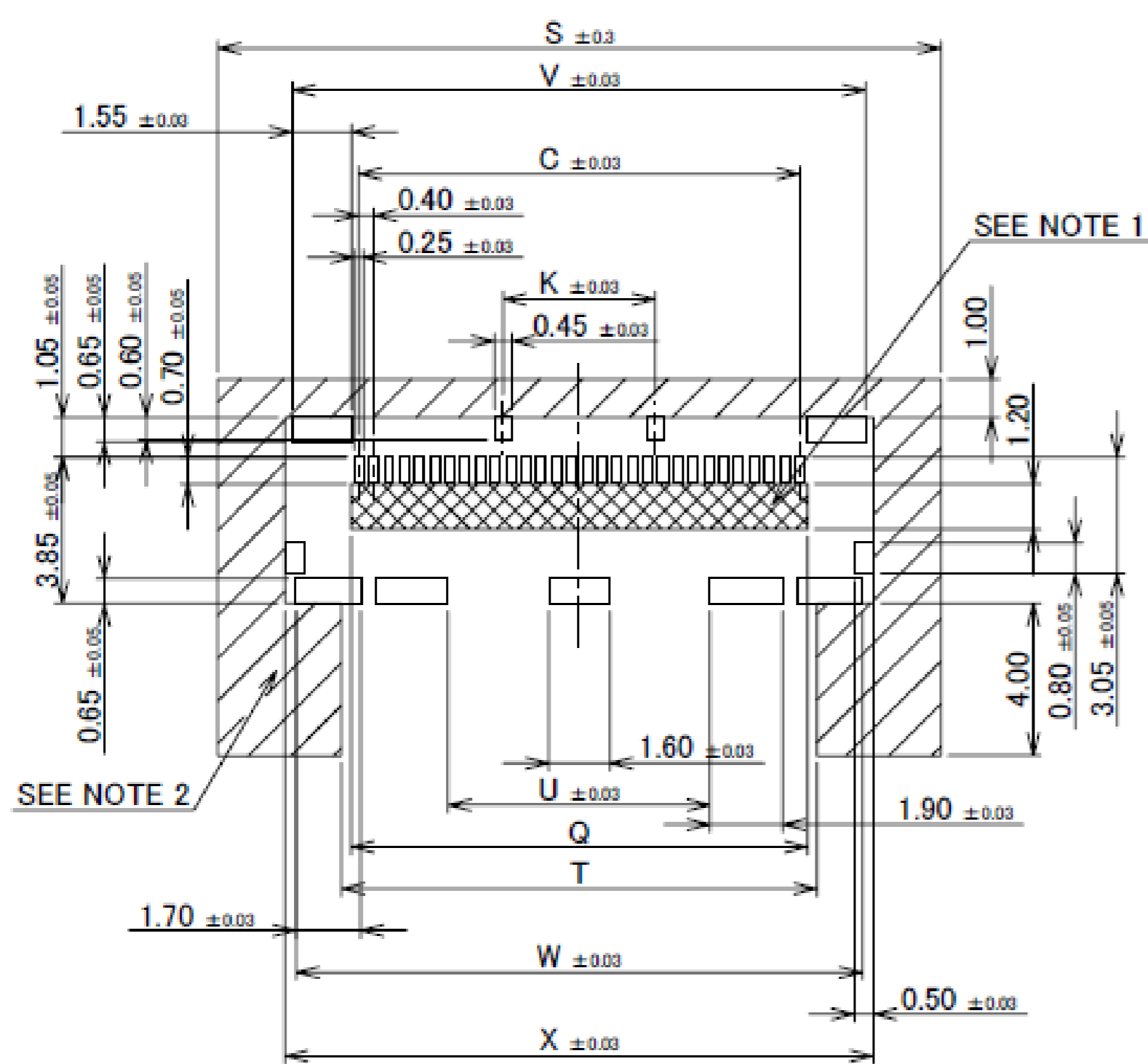

02 TYPE 30P RECOMMENDED PCB LAYOUT [TYPE A]  
(S = 5 : 1)

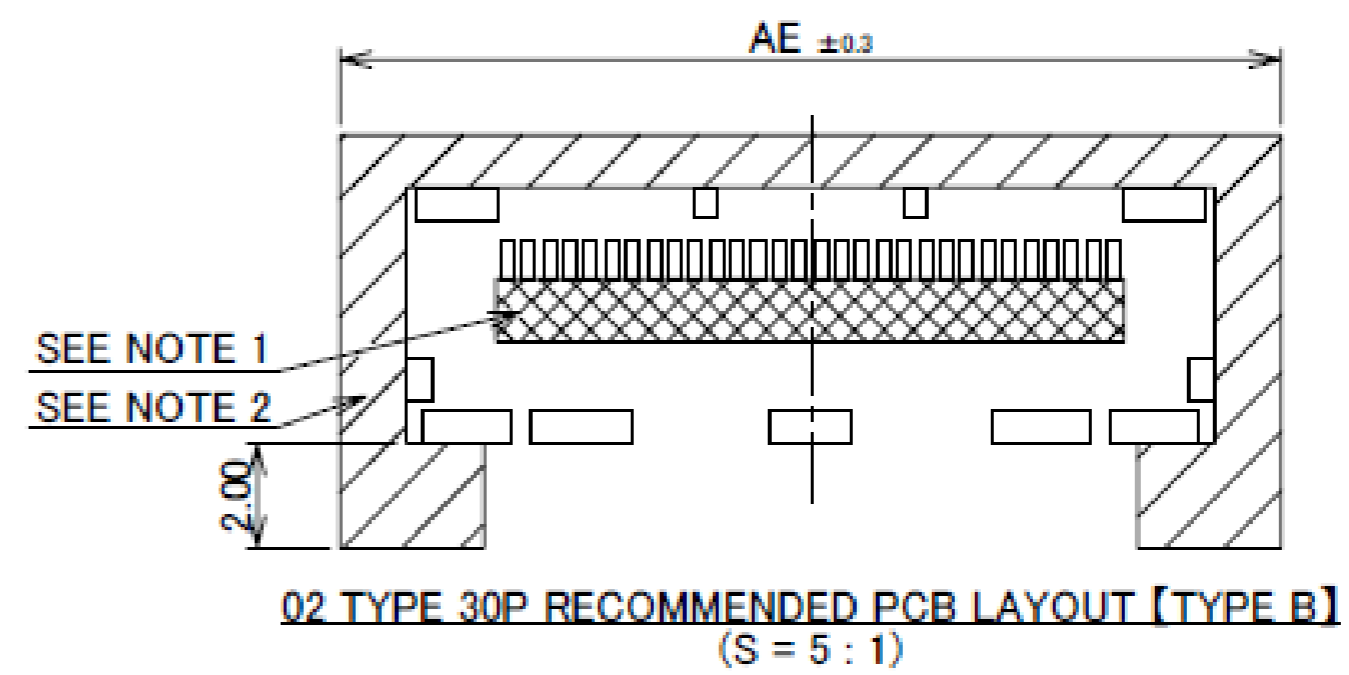

02 TYPE 30P RECOMMENDED PCB LAYOUT [TYPE B]  
(S = 5 : 1)

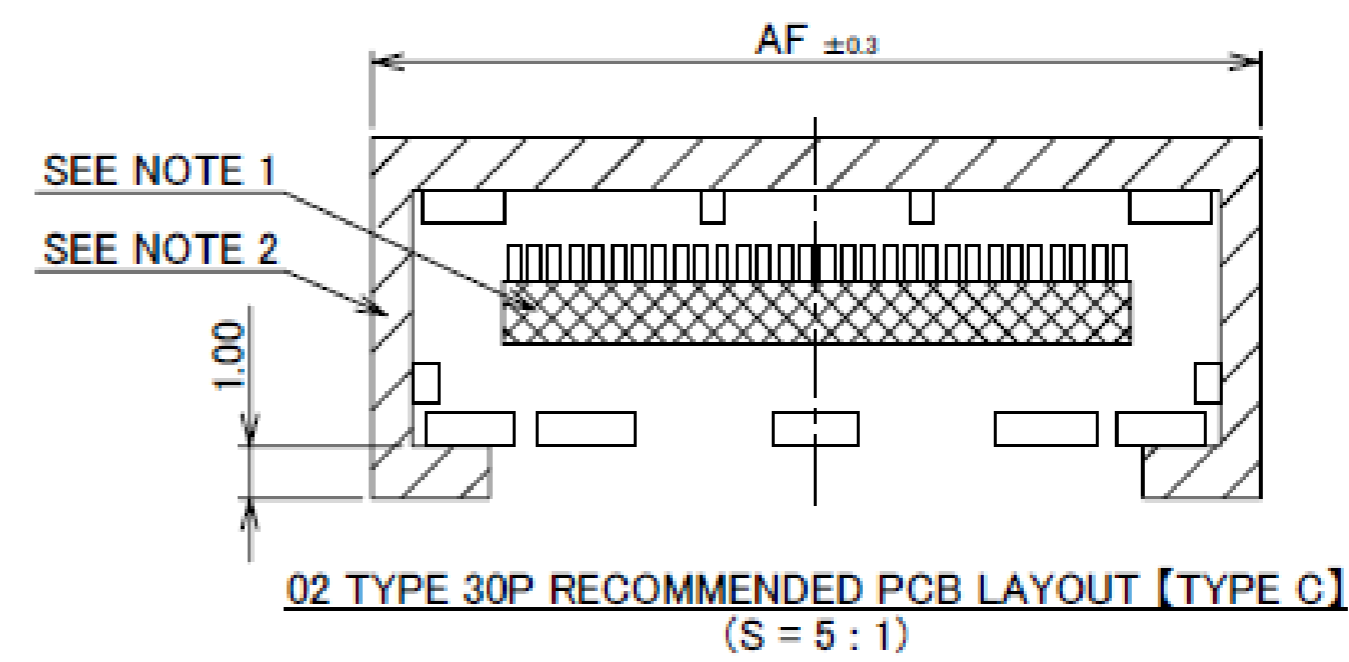

02 TYPE 30P RECOMMENDED PCB LAYOUT [TYPE C]  
(S = 5 : 1)

NOTES.

1. SOLDER RESIST MUST BE APPLIED TO THIS AREA.
  2. DO NOT MOUNT ANOTHER COMPONENT IN THIS AREA.
- THIS AREA VARIES DEPENDING ON WHETHER THE PULL JIG IS USED, AND THE PART NUMBER OF THE PLUG CABLE ASSEMBLY BEING USED. FOR DETAILS ON THE PULL JIG, PLEASE REFER TO HIM-18033.

Rev.18

PART No.	Pos.	C	K	L	Q	S	T	U	V	W	X	AE	AF
20879-040E-02	40	15.60	8.00	4.00	16.00	23.00	16.50	6.50	19.07	18.89	19.47	22.00	21.00

## 02 TYPE

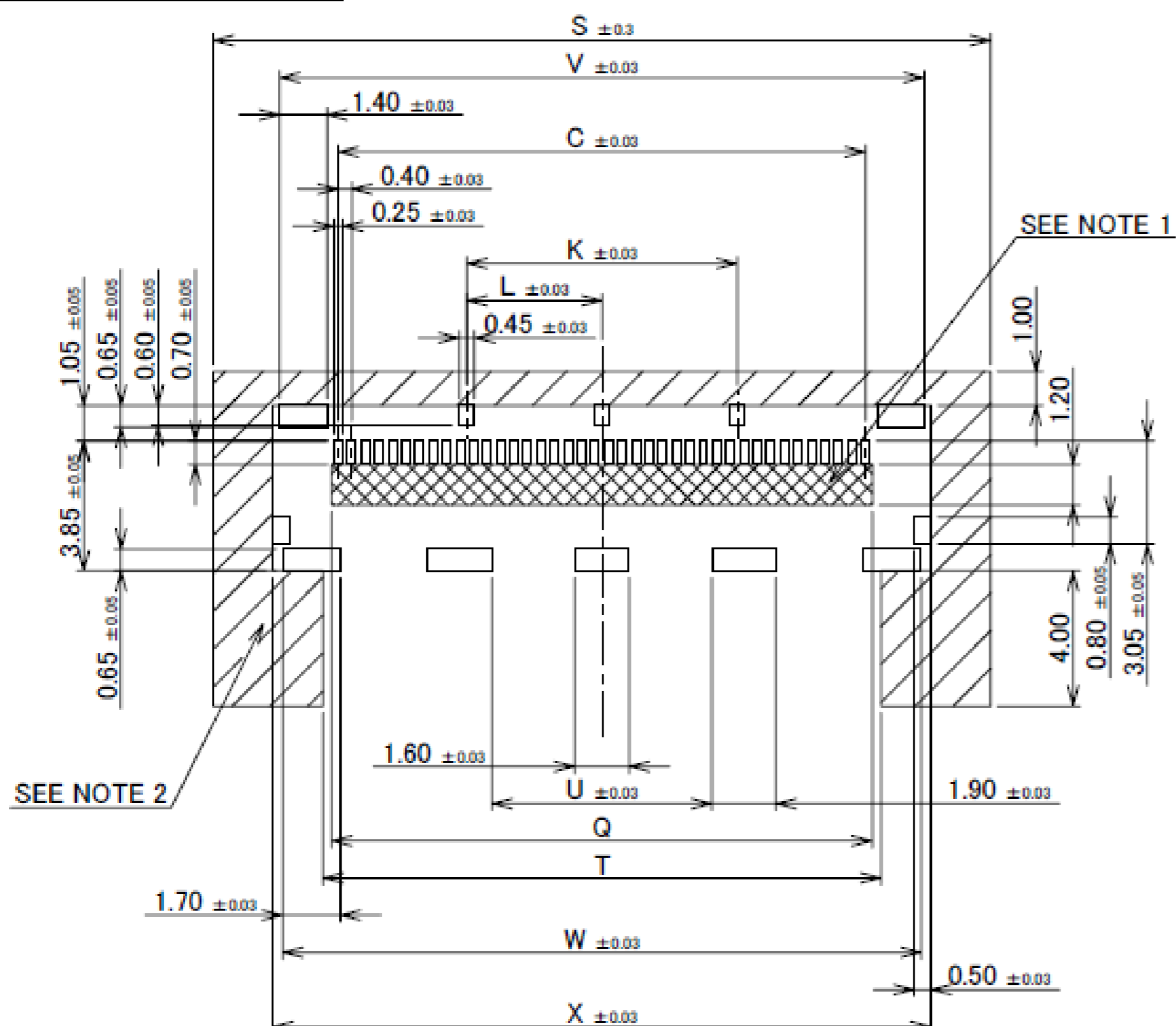

02 TYPE 40P RECOMMENDED PCB LAYOUT [TYPE A]  
(S = 5 : 1)

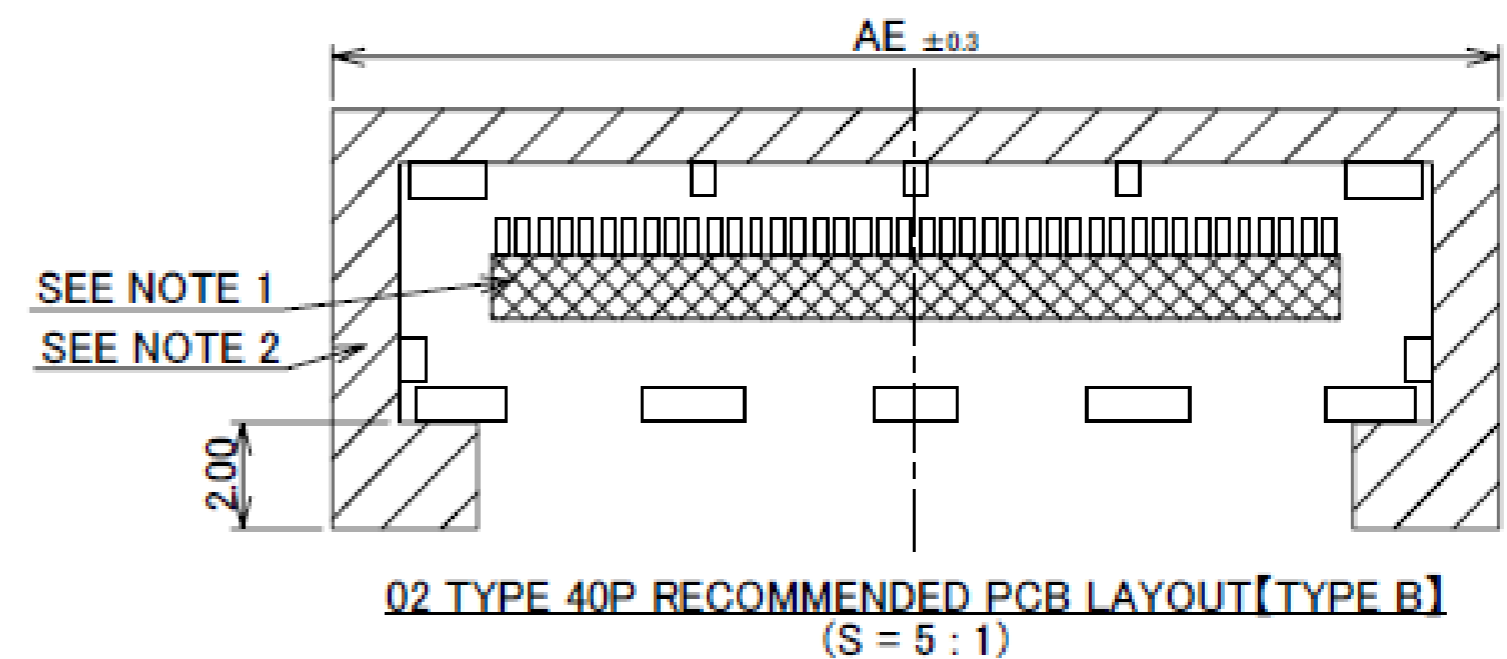

02 TYPE 40P RECOMMENDED PCB LAYOUT [TYPE B]  
(S = 5 : 1)

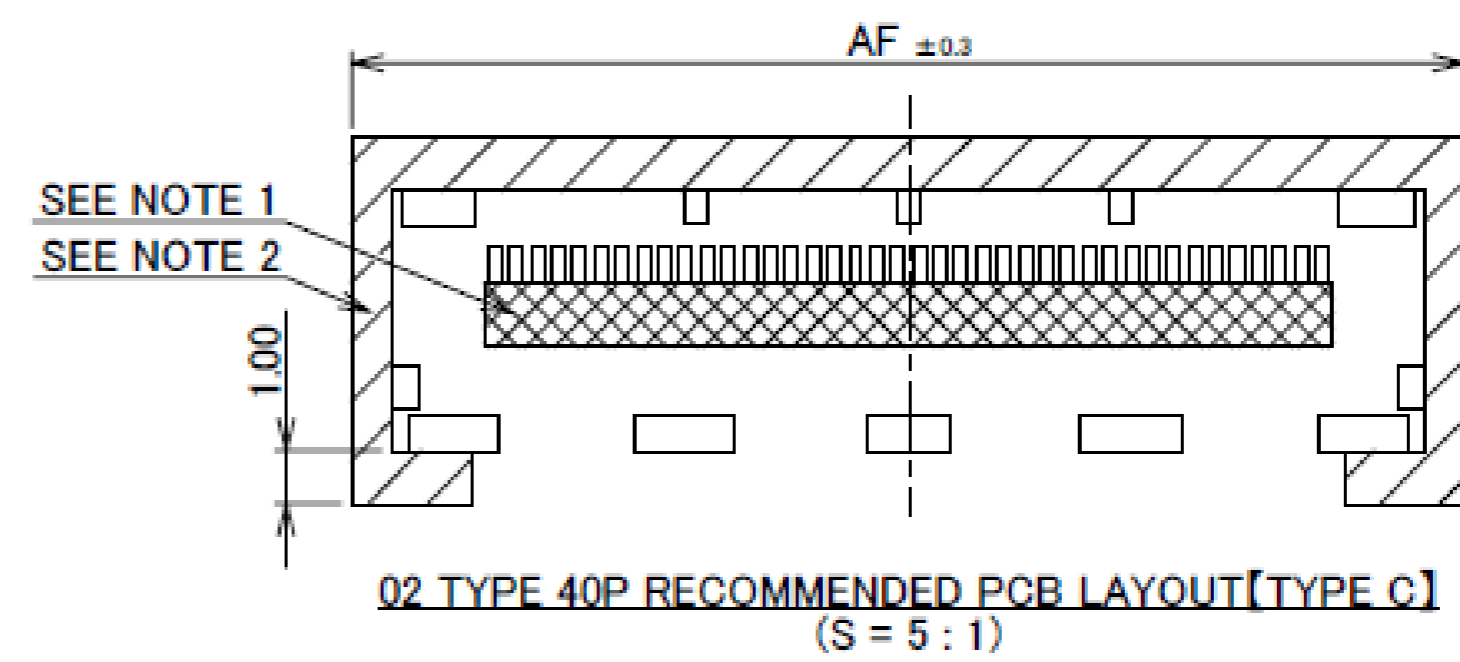

02 TYPE 40P RECOMMENDED PCB LAYOUT [TYPE C]  
(S = 5 : 1)

NOTES.

1. SOLDER RESIST MUST BE APPLIED TO THIS AREA.
  2. DO NOT MOUNT ANOTHER COMPONENT IN THIS AREA.
- THIS AREA VARIES DEPENDING ON WHETHER THE PULL JIG IS USED, AND THE PART NUMBER OF THE PLUG CABLE ASSEMBLY BEING USED. FOR DETAILS ON THE PULL JIG, PLEASE REFER TO HIM-18033.

Rev.18

# Receptacle Assembly

PART No.	Pos.	C	K	L	P	Q	S	T	U	V	W	X	AE	AF
20879-050E-02	50	19.60	14.40	3.60	7.20	20.00	27.00	20.50	8.50	23.07	22.89	23.47	26.00	25.00

## 02 TYPE

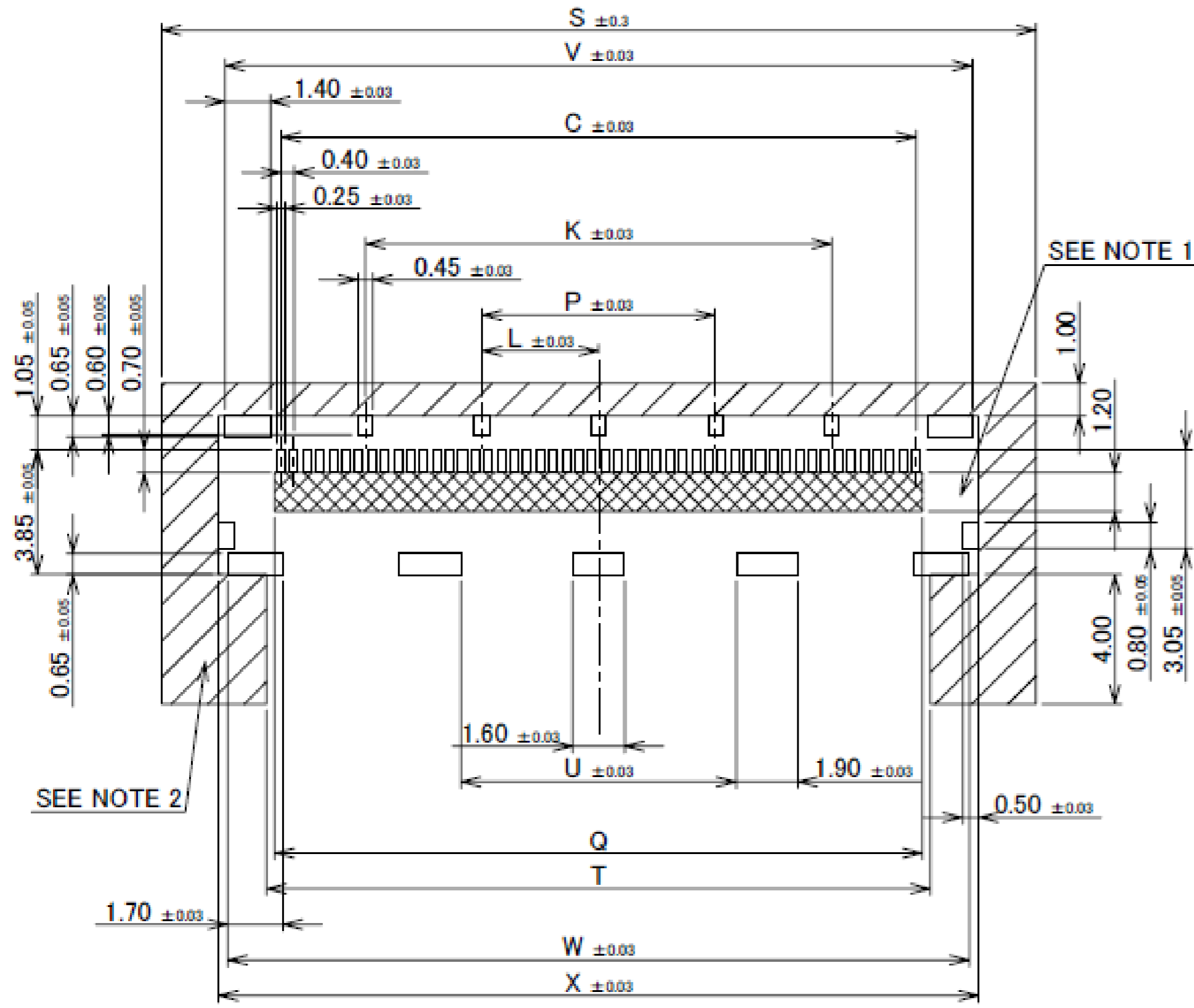

02TYPE 50P RECOMMENDED PCB LAYOUT [TYPE A]  
(S = 5 : 1)

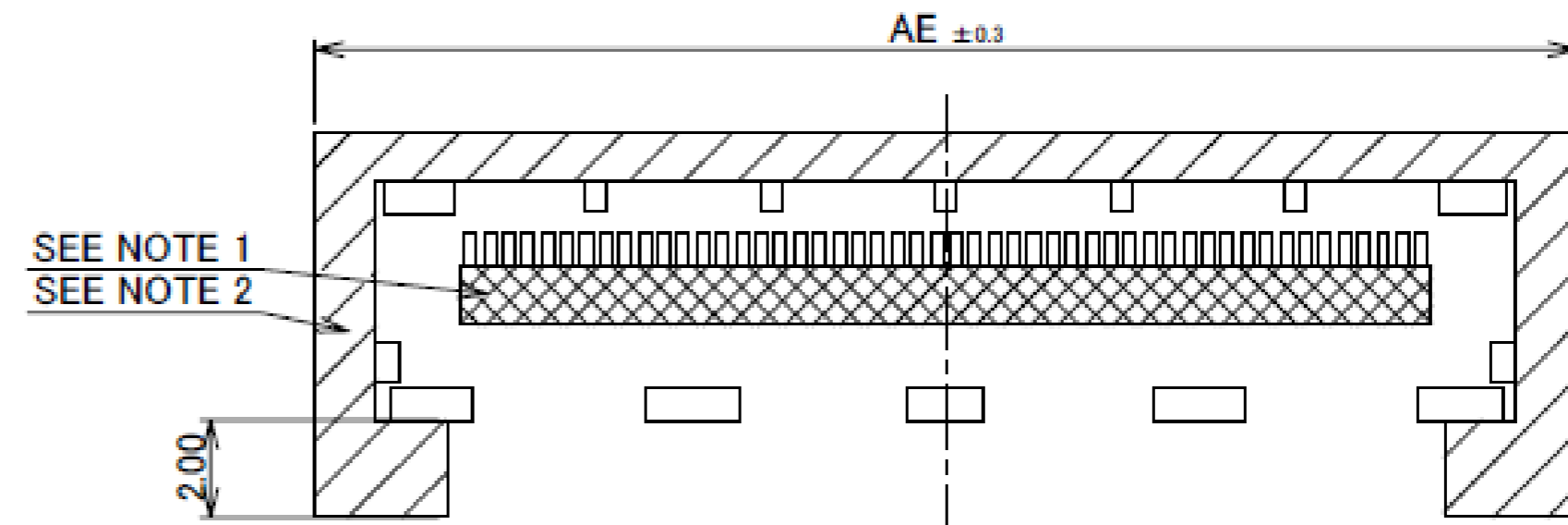

02TYPE 50P RECOMMENDED PCB LAYOUT [TYPE B]  
(S = 5 : 1)

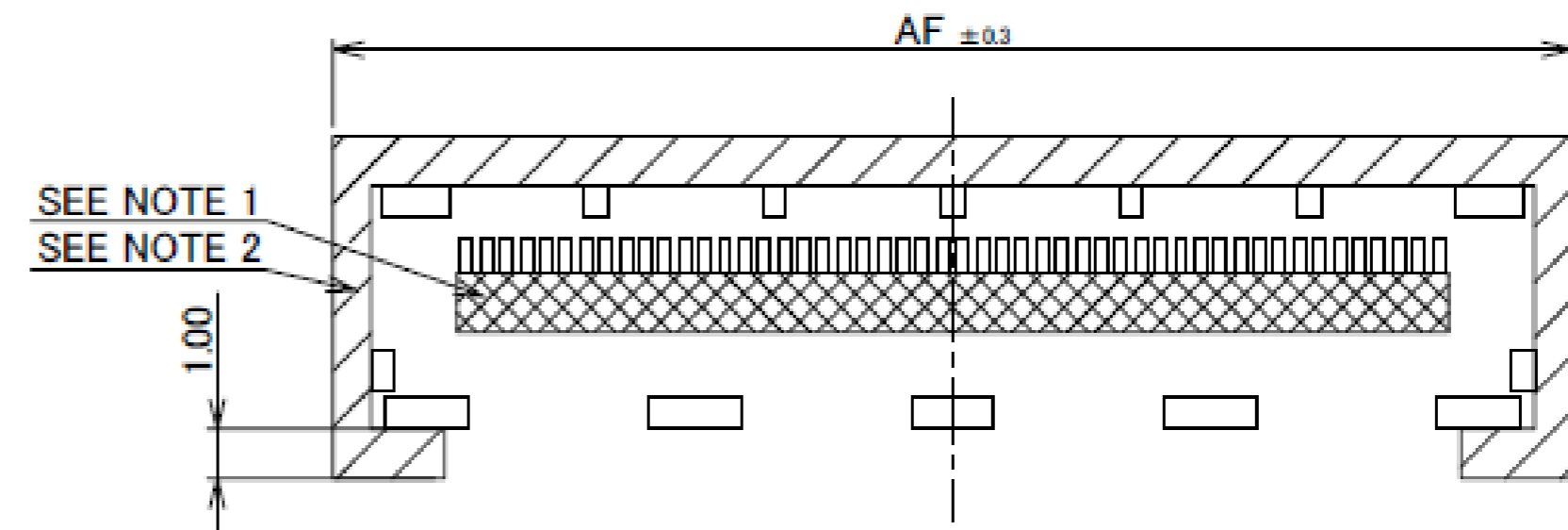

02TYPE 50P RECOMMENDED PCB LAYOUT [TYPE C]  
(S = 5 : 1)

### NOTES.

1. SOLDER RESIST MUST BE APPLIED TO THIS AREA.
  2. DO NOT MOUNT ANOTHER COMPONENT IN THIS AREA.
- THIS AREA VARIES DEPENDING ON WHETHER THE PULL JIG IS USED,  
AND THE PART NUMBER OF THE PLUG CABLE ASSEMBLY BEING USED.  
FOR DETAILS ON THE PULL JIG, PLEASE REFER TO HIM-18033.

Rev.18

PART No.	Pos.	C	K	L	P	Q	S	T	U	V	W	X	AD	AE	AF
20879-060E-02	60	23.60	17.60	-	11.20	24.00	31.00	24.50	10.50	27.07	26.89	27.47	3.20	30.00	29.00

## 02 TYPE

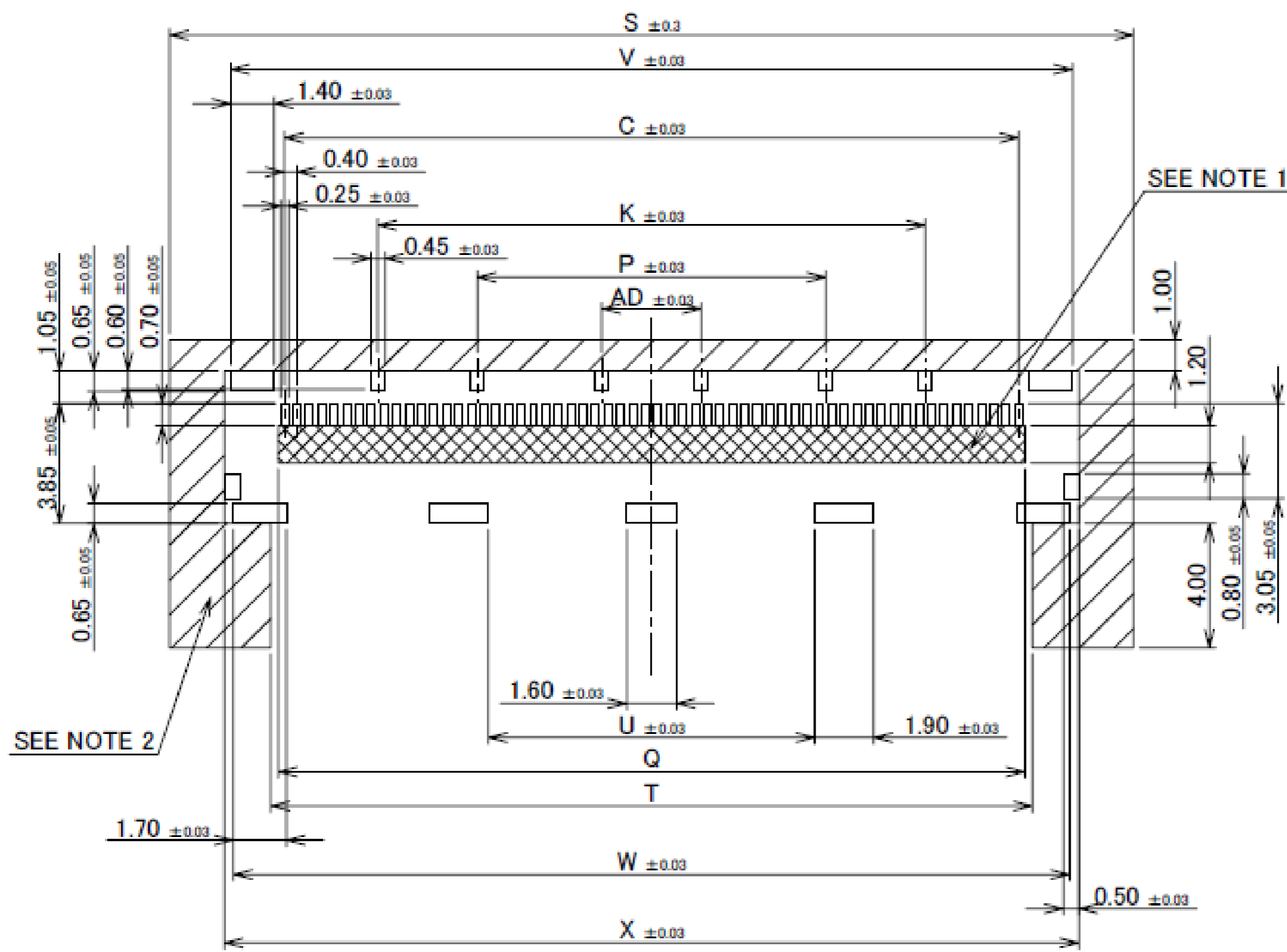

02 TYPE 60P RECOMMENDED PCB LAYOUT  
(S = 5 : 1)

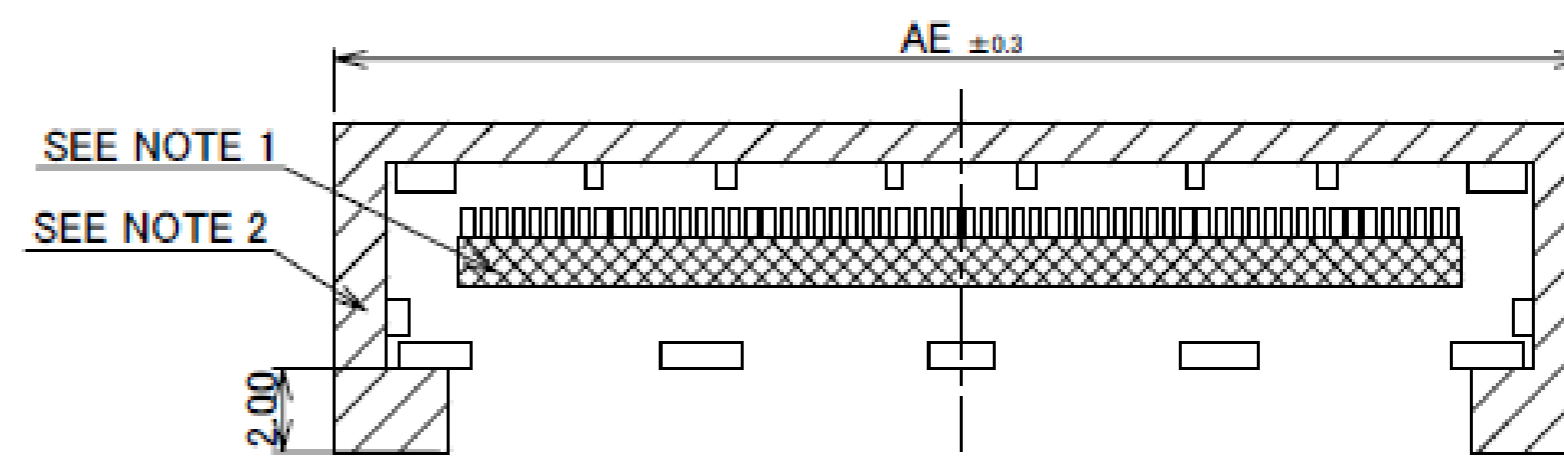

02 TYPE 60P RECOMMENDED PCB LAYOUT  
(S = 4 : 1)

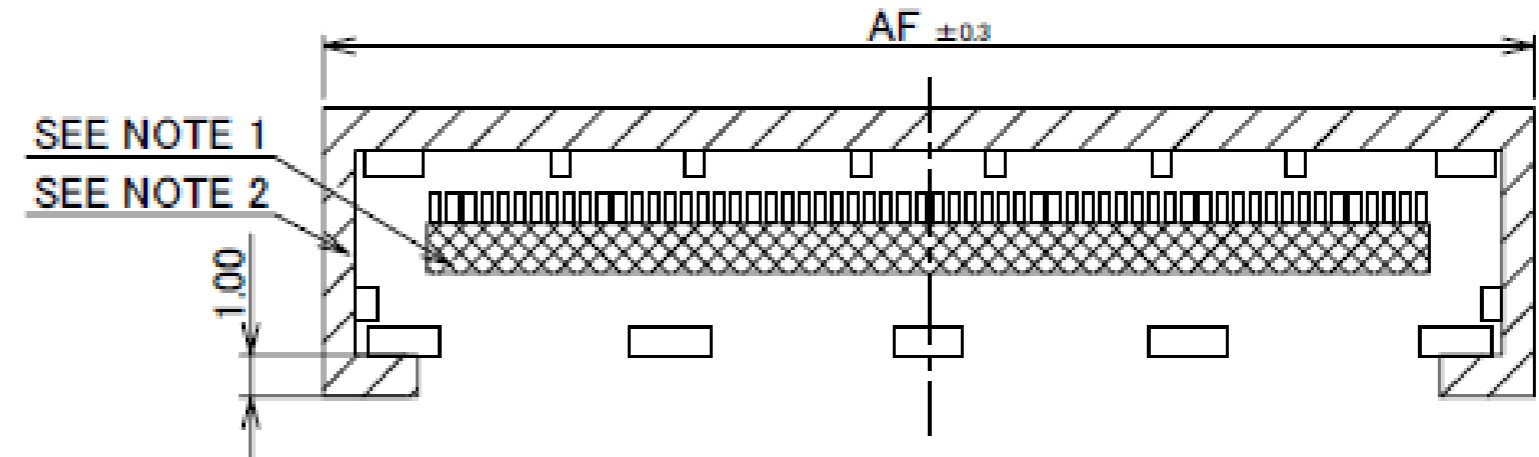

02 TYPE 60P RECOMMENDED PCB LAYOUT  
(S = 4 : 1)

### NOTES.

1. SOLDER RESIST MUST BE APPLIED TO THIS AREA.
  2. DO NOT MOUNT ANOTHER COMPONENT IN THIS AREA.
- THIS AREA VARIES DEPENDING ON WHETHER THE PULL JIG IS USED,  
AND THE PART NUMBER OF THE PLUG CABLE ASSEMBLY BEING USED.  
FOR DETAILS ON THE PULL JIG, PLEASE REFER TO HIM-18033.

Rev.18

# Receptacle Assembly

PART No.	Pos.
20879-030E-02	30
20879-040E-02	40
20879-050E-02	50
20879-060E-02	60
20879-070E-02	70

02 TYPE

With LOCK COVER

Without LOCK COVER & With PULL TAPE HOLDER

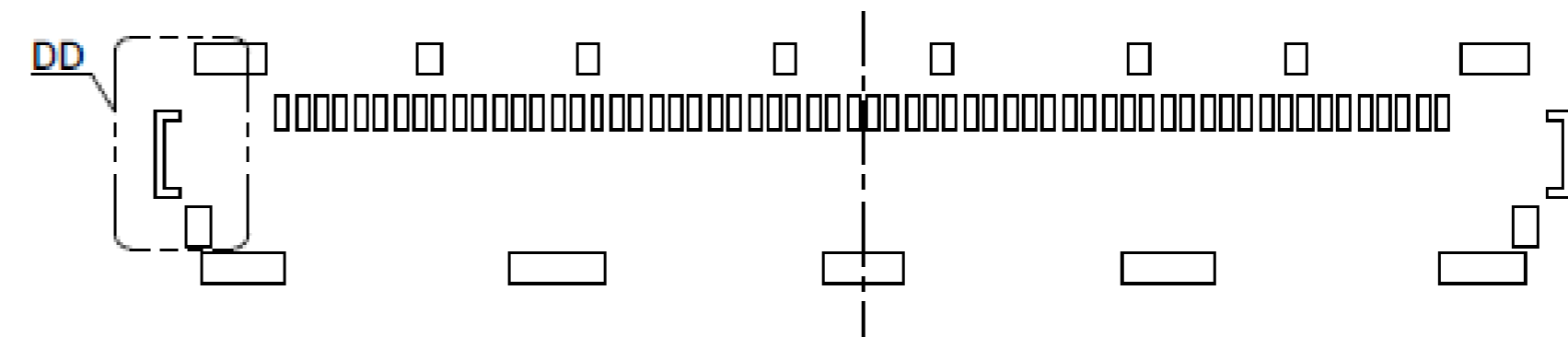
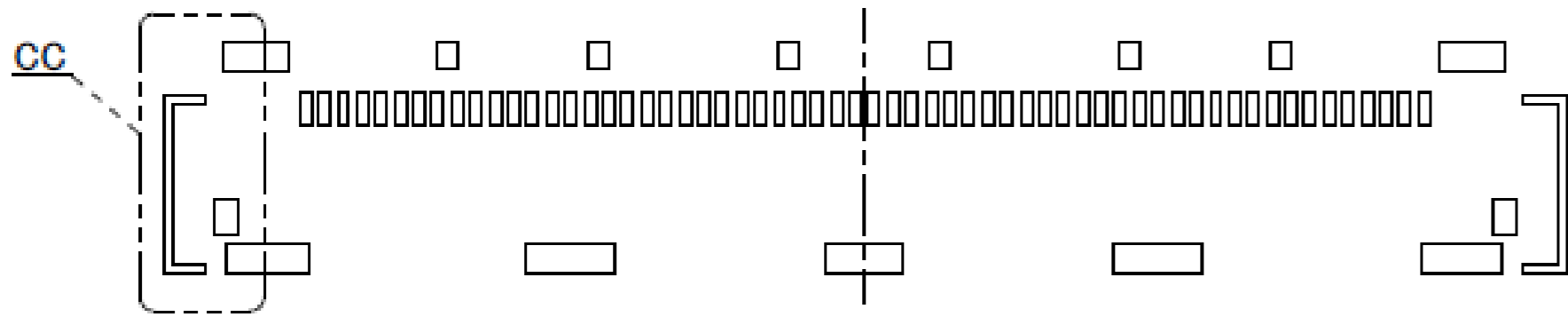

RECOMMENDED SILK PRINT For With LOCK COVER (S = 5 : 1)

RECOMMENDED SILK PRINT For Without LOCK COVER (S = 5 : 1)

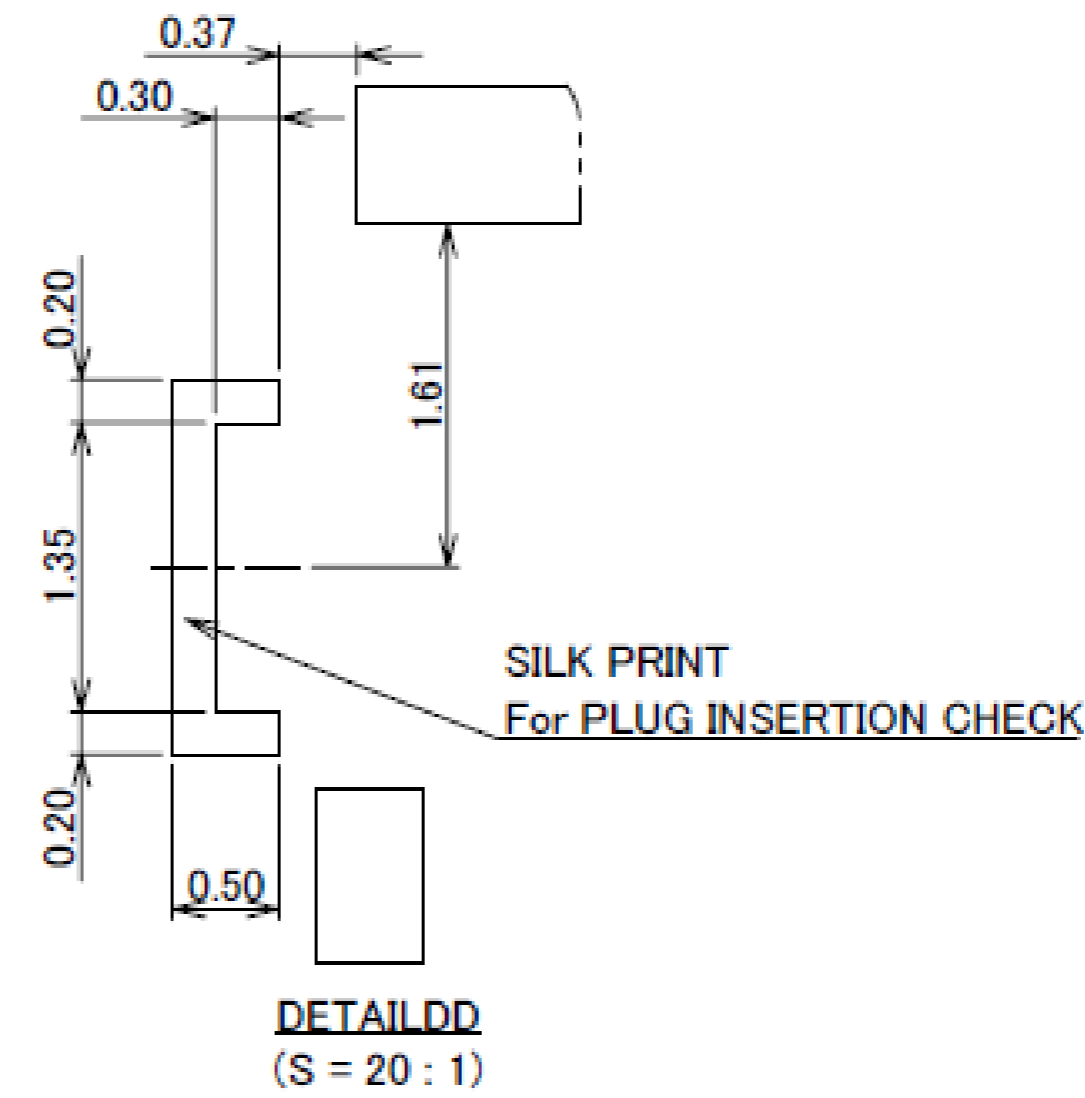
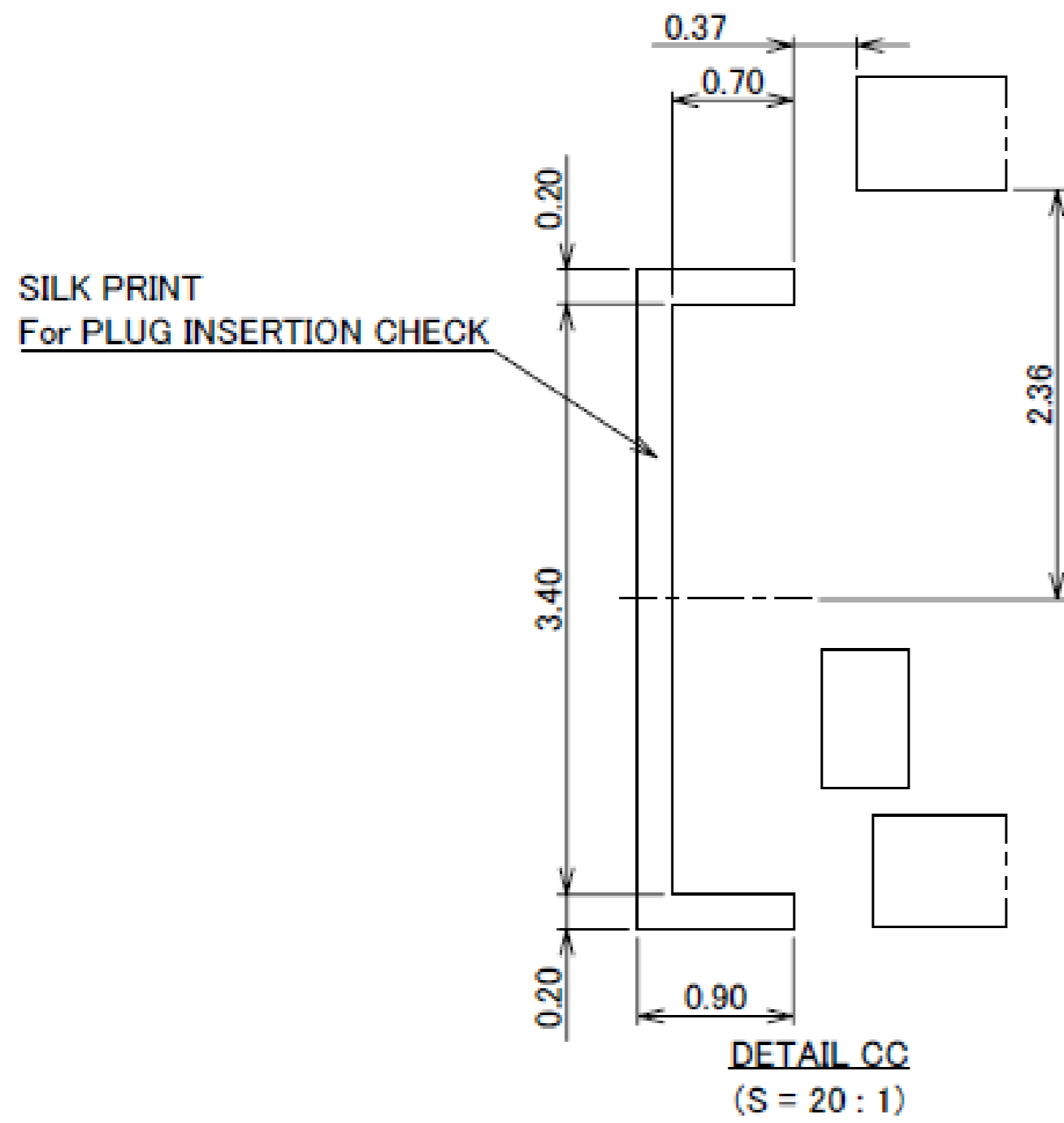

Rev.18

PART No.	Pos.	B	C	D	F	P	R
20879-030E-#1	30	13.01	11.60	9.60	12.88	15.17	15.07
20879-040E-#1	40	17.01	15.60	14.40	16.88	19.17	19.07
20879-060E-#1	60	25.01	23.60	21.60	24.88	27.17	27.07

#1 TYPE

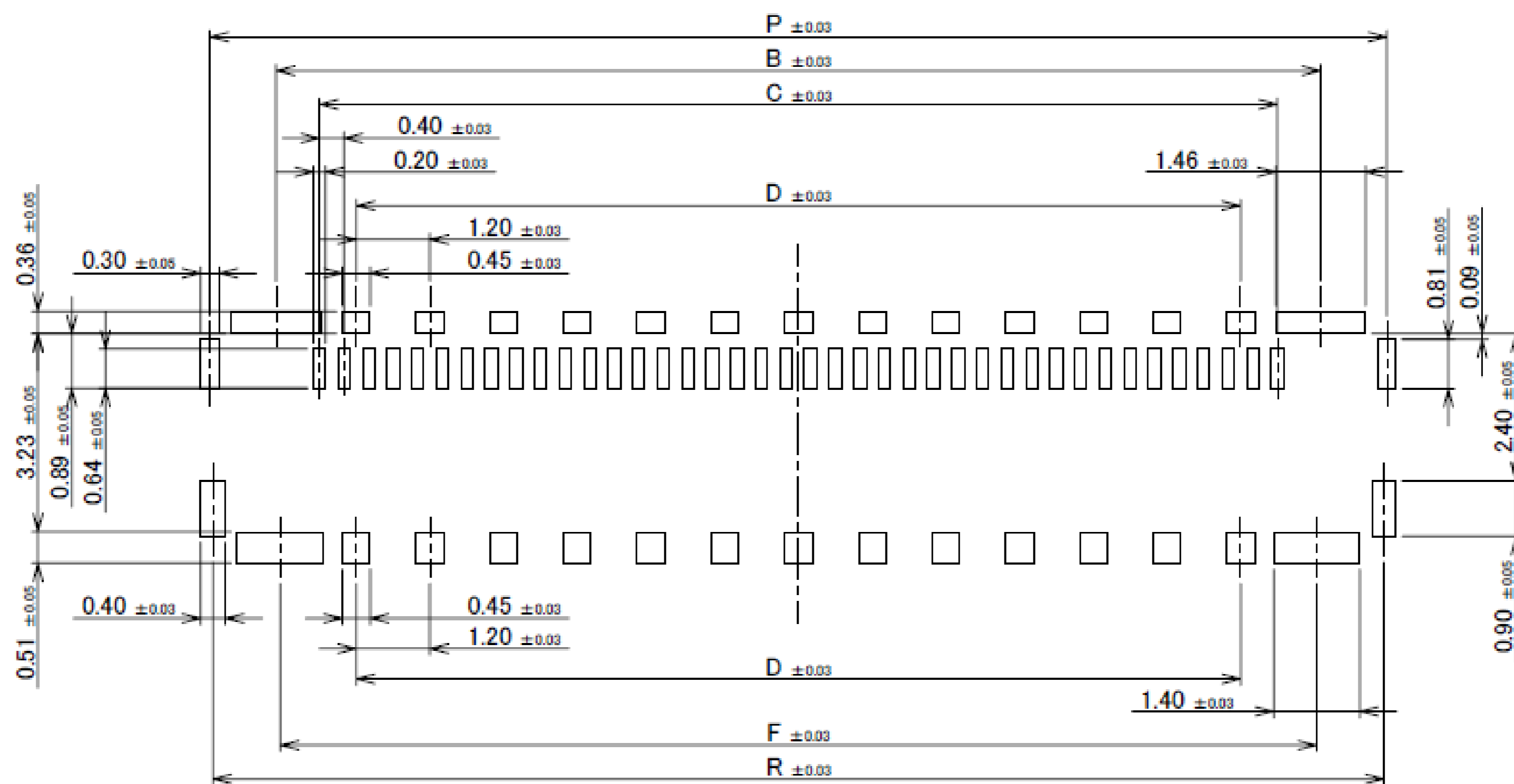

#1 TYPE 30P, 40P, 60P RECOMMENDED METAL MASK LAYOUT (S = 10 : 1)  
※ METAL MASK THICKNESS : t = 0.10

Rev.18

# Receptacle Assembly

PART No.	Pos.	B	C	D	F	P	R
20879-050E-#1	50	21.01	19.60	17.60	20.88	23.17	23.07

#1 TYPE

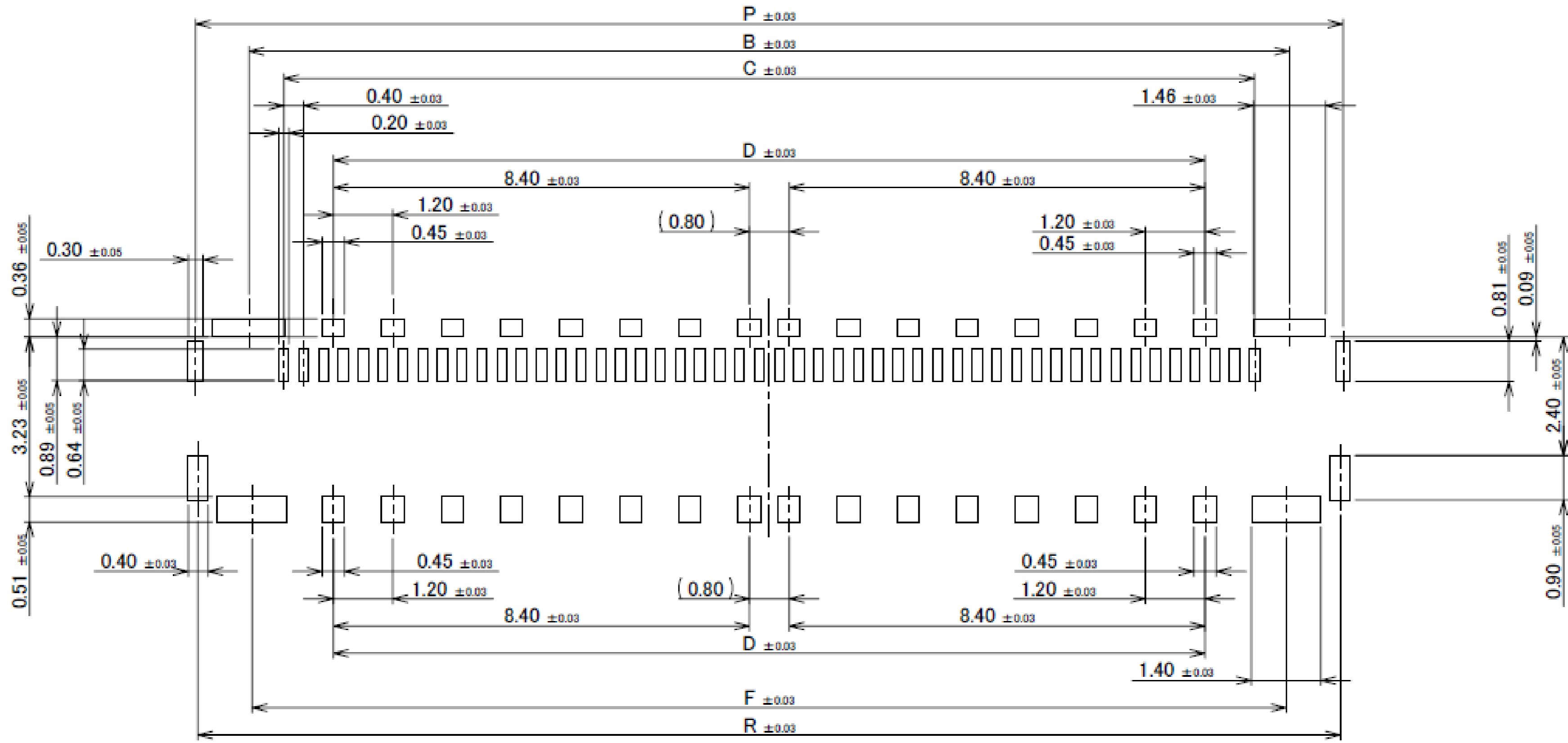

#1 TYPE 50P RECOMMENDED METAL MASK LAYOUT (S = 10 : 1)  
※ METAL MASK THICKNESS : t = 0.10

Rev.18

PART No.	Pos.	C	K	L	U	V	W	X
20879-030E-02	30	11.60	4.00	-	6.89	15.07	14.89	15.47
20879-040E-02	40	15.60	8.00	4.00	6.50	19.07	18.89	19.47
20879-050E-02	50	19.60	14.40	3.60	8.50	23.07	22.89	23.47
20879-060E-02	60	23.60	17.60	-	10.50	27.07	26.89	27.47
20879-070E-02	70	27.60	20.00	-	11.30	31.07	30.89	31.47

02 TYPE

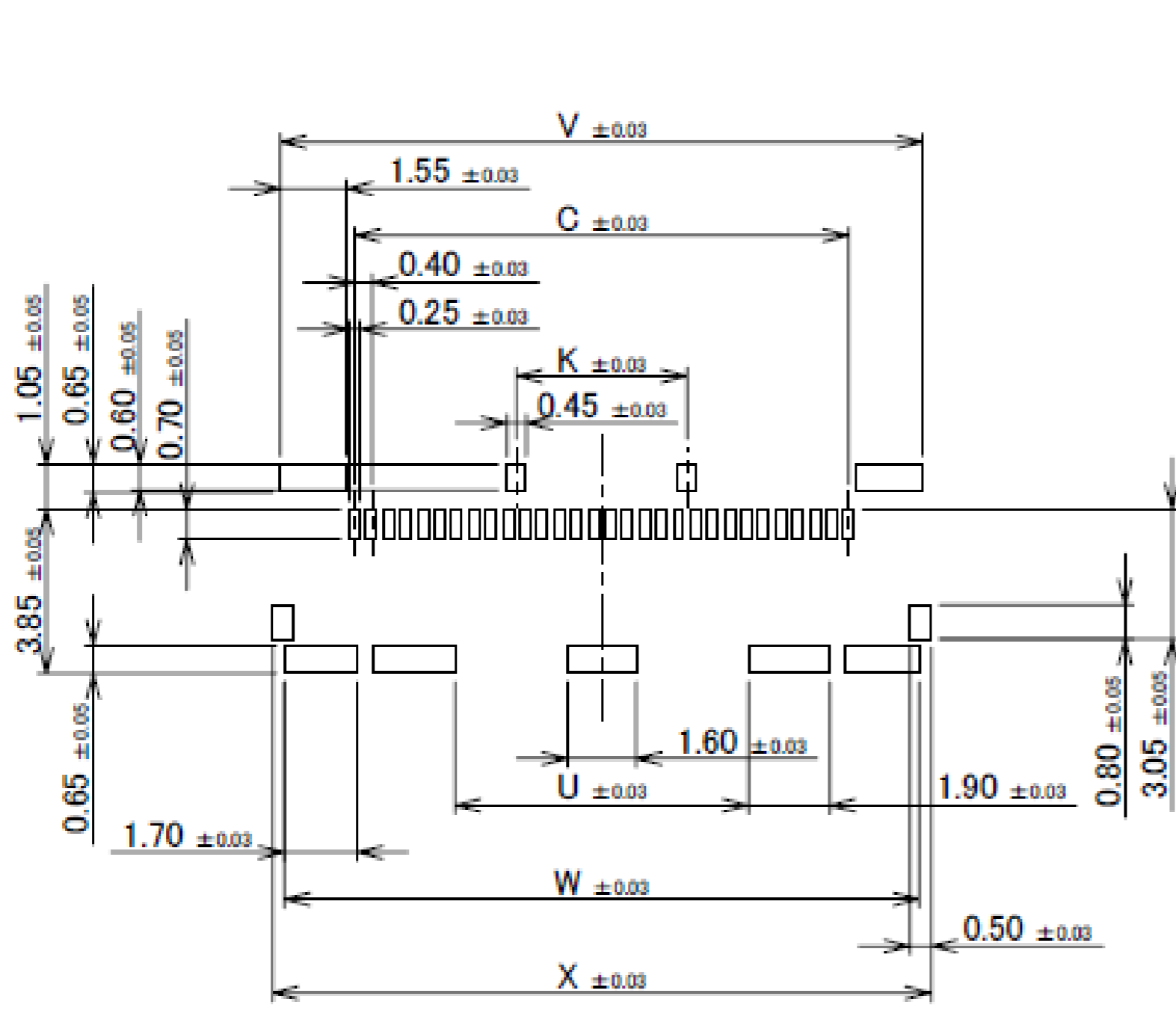

02 TYPE 30P RECOMMENDED METAL MASK LAYOUT (S = 5 : 1)  
※ METAL MASK THICKNESS : t = 0.12

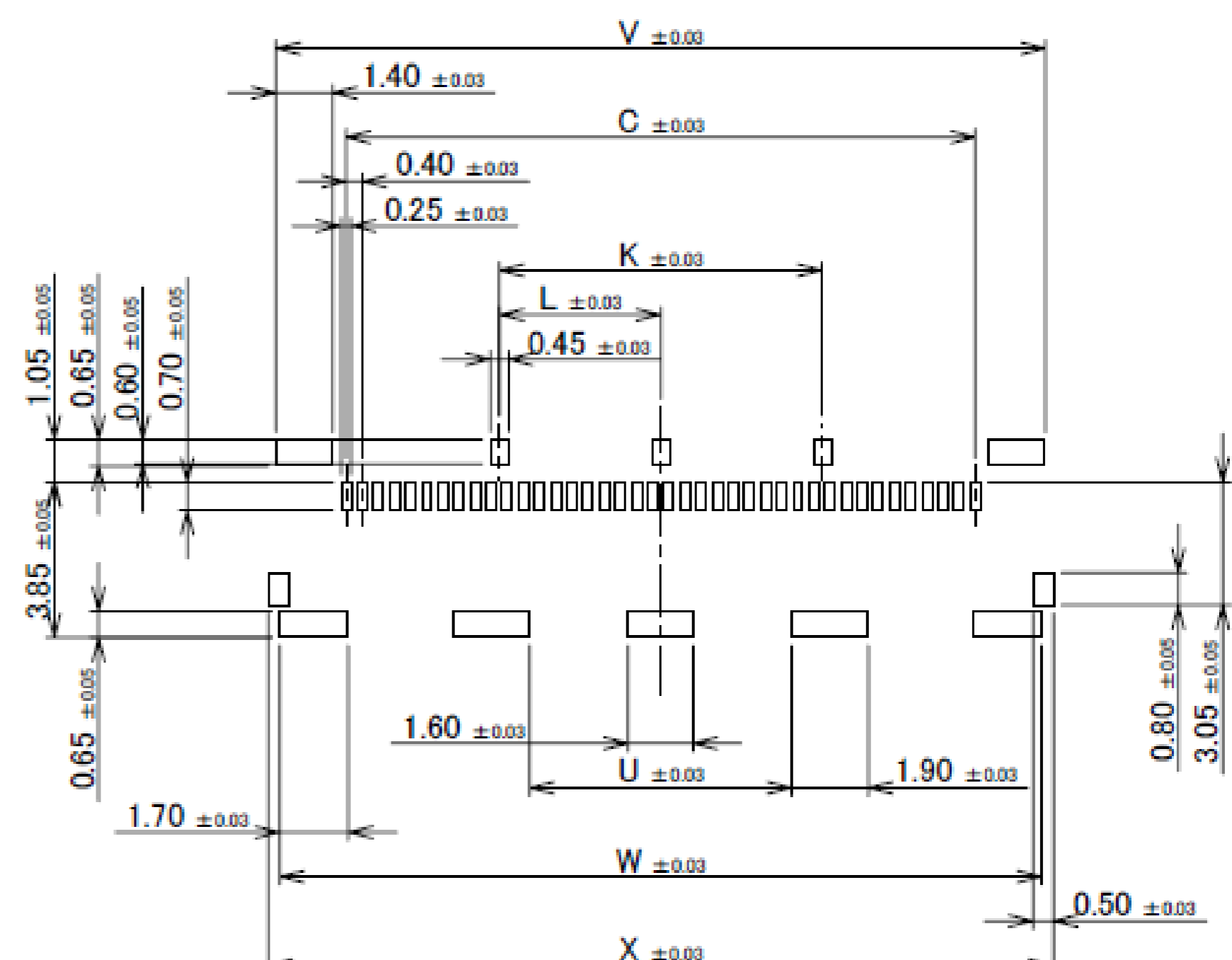

02 TYPE 40P RECOMMENDED METAL MASK LAYOUT (S = 5 : 1)  
※ METAL MASK THICKNESS : t = 0.12

Rev.18

# Receptacle Assembly

PART No.	Pos.	C	K	L	P	U	V	W	X	AD
20879-030E-02	30	11.60	4.00	-	-	6.89	15.07	14.89	15.47	-
20879-040E-02	40	15.60	8.00	4.00	-	6.50	19.07	18.89	19.47	-
20879-050E-02	50	19.60	14.40	3.60	7.20	8.50	23.07	22.89	23.47	-
20879-060E-02	60	23.60	17.60	-	11.20	10.50	27.07	26.89	27.47	3.20
20879-070E-02	70	27.60	20.00	-	12.00	11.30	31.07	30.89	31.47	4.00

02 TYPE

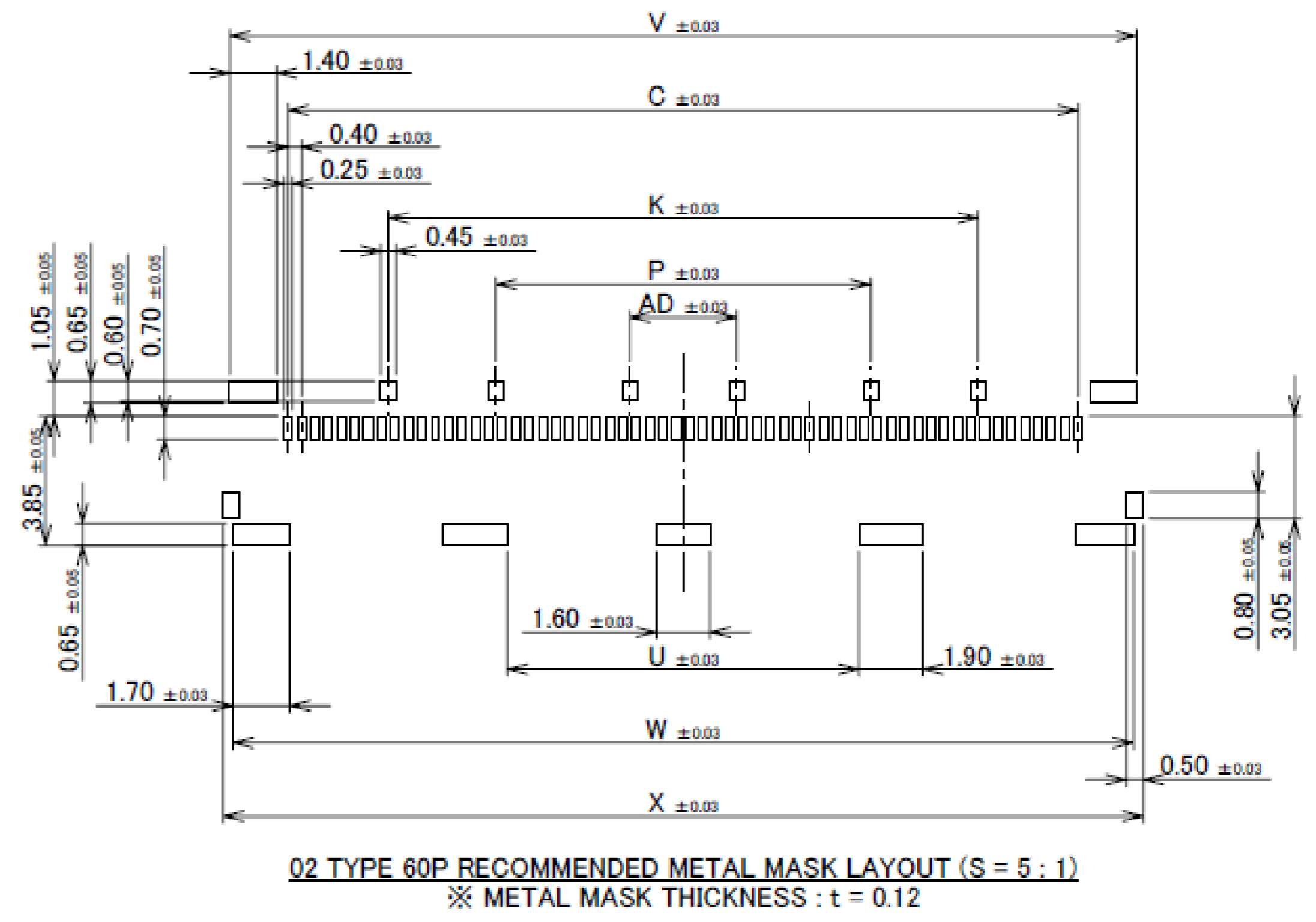
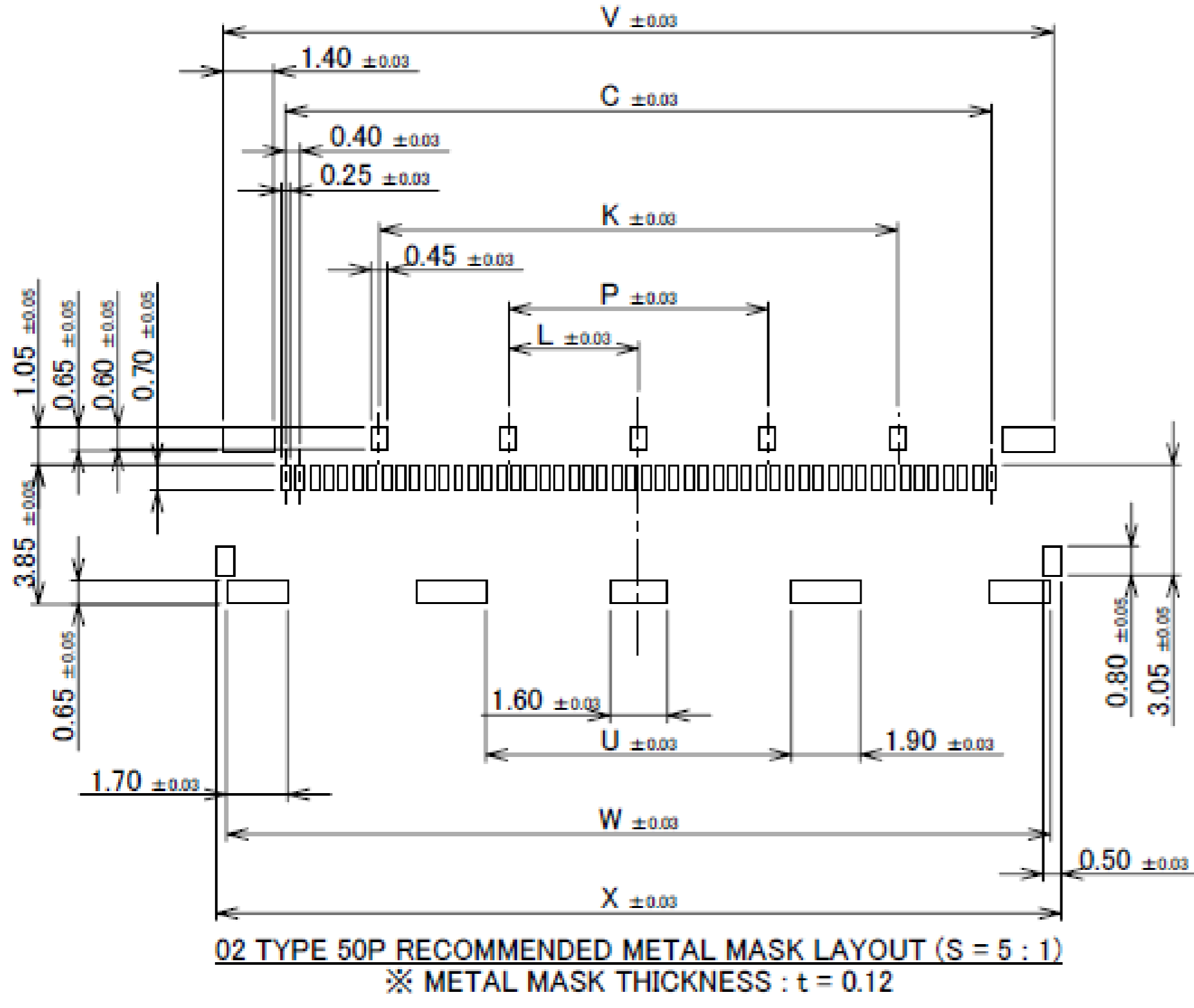

Rev.18

PART No.	Pos.	C	K	L	P	U	V	W	X	AD
20879-030E-02	30	11.60	4.00	-	-	6.89	15.07	14.89	15.47	-
20879-040E-02	40	15.60	8.00	4.00	-	6.50	19.07	18.89	19.47	-
20879-050E-02	50	19.60	14.40	3.60	7.20	8.50	23.07	22.89	23.47	-
20879-060E-02	60	23.60	17.60	-	11.20	10.50	27.07	26.89	27.47	3.20
20879-070E-02	70	27.60	20.00	-	12.00	11.30	31.07	30.89	31.47	4.00

02 TYPE

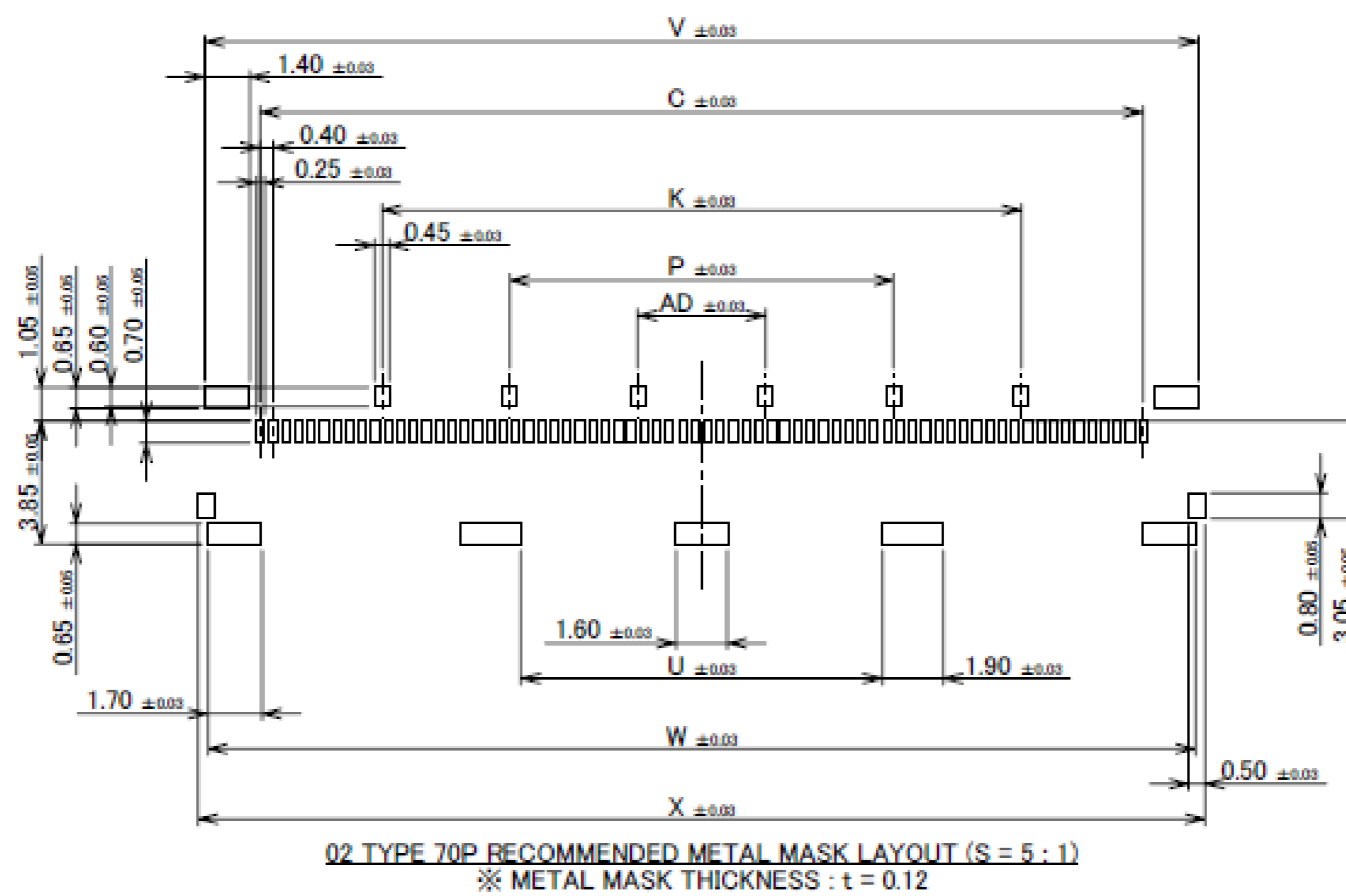

Rev.18

# Receptacle Assembly

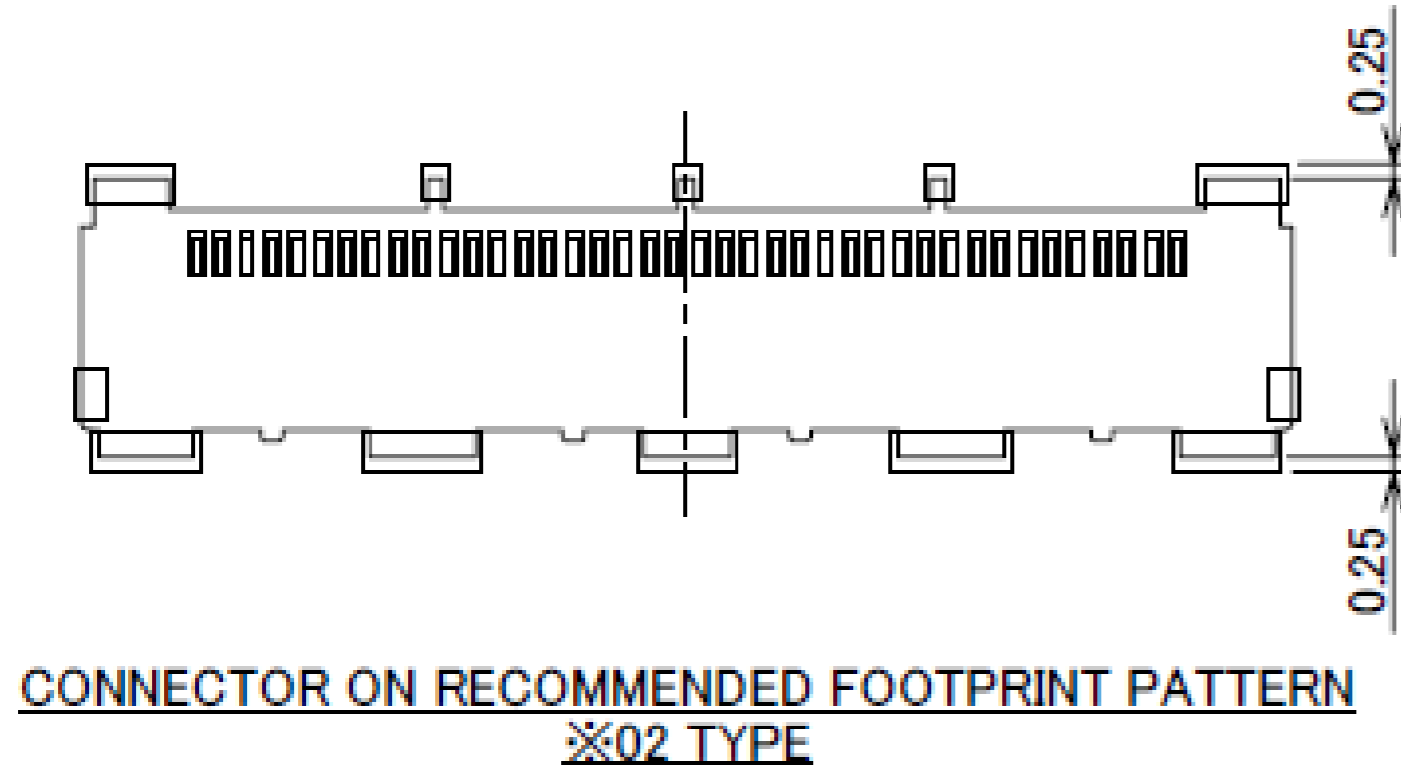
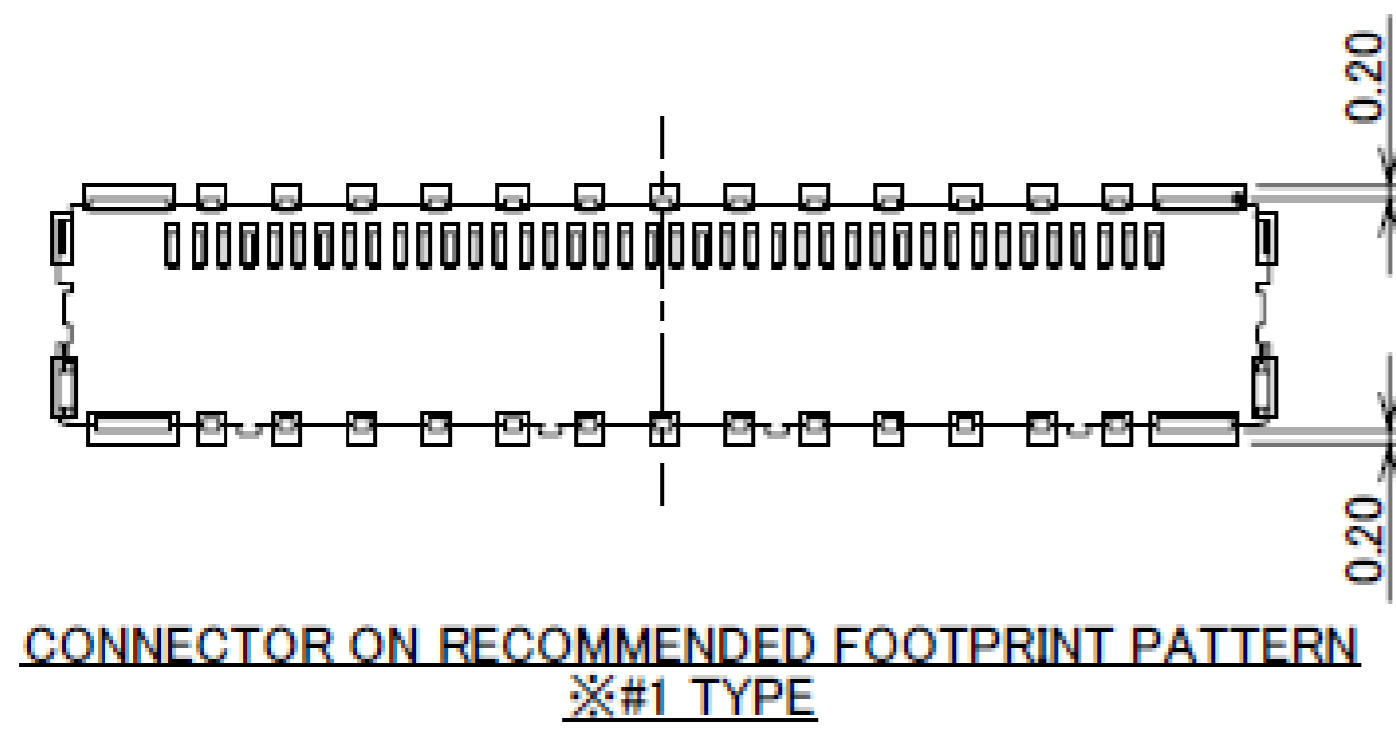

REFLOW TEMPERATURE PROFILE  
SENJU METAL INDUSTRY CO., LTD. : M705-SHF(Sn96.5 Ag3.0 Cu0.5)

Rev.18

ITEMS	SPECIFICATION
APPLICABLE CABLE	MICRO-COAXIAL CABLE : AWG #44 , 42 , 40 , 38 , 36 DISCRETE WIRE : AWG #36 , 34 TWINAXIAL CABLE : AWG #40 , 42
RATED VOLTAGE	100V AC (PER CONTACT PIN) ※THIS IS THE RATED VOLTAGE OF THE CONNECTOR. PLEASE NOTE THAT THE RATED VOLTAGE MAY VARY IN THE HARNESS DEPENDING ON THE CABLES USED.
RATED AMPERAGE (FOR CONTACT)	0.15A AC/DC [AWG #44] PER CONTACT PIN/UP TO 60 CONTACTS 0.24A AC/DC [AWG #42] PER CONTACT PIN/UP TO 49 CONTACTS 0.3A AC/DC [AWG #40] PER CONTACT PIN/UP TO 38 CONTACTS 0.5A AC/DC [AWG #38] PER CONTACT PIN/UP TO 19 CONTACTS 0.8A AC/DC [AWG #36] PER CONTACT PIN/UP TO 12 CONTACTS 1.0A AC/DC [AWG #34] PER CONTACT PIN/UP TO 10 CONTACTS ※TESTING BY A REAL MACHINE IS RECOMMENDED BECAUSE TEMPERATURE RISE MAY AFFECTED BY ACTUAL SITUATION.
OPERATING TEMPERATURE	233 TO 378K(-40°C TO +105°C)
OPERATING HUMIDITY	85% MAX.
CONTACT RESISTANCE	INITIAL : 180mohm MAX.(AWG #34) / AFTER TEST : 440mohm MAX. 275mohm MAX.(AWG #36) 360mohm MAX.(AWG #38) 600mohm MAX.(AWG #40) 700mohm MAX.(AWG #42) 1080mohm MAX.(AWG #44)
GROUND SHELL RESISTANCE	INITIAL : 50mohm MAX. / AFTER TEST : 440mohm MAX.
INSULATION RESISTANCE	INITIAL : 1000Mohm MIN. / AFTER TEST : 500Mohm MIN.
DIELECTRIC WITHSTANDING VOLTAGE	AC250V 1min
DURABILITY	30 CYCLES
MATING FORCE (INITIAL / AFTER TEST)	30P : 34.00N MAX. 40P : 40.00N MAX. 50P : 46.00N MAX. 60P : 52.00N MAX. 70P : 58.00N MAX.
UNMATING FORCE (INITIAL / AFTER TEST)	30P : 3.0N MIN. 40P : 4.0N MIN. 50P : 5.0N MIN. 60P : 6.0N MIN. 70P : 7.0N MIN.
CABLE RETENTION FORCE	30P : 14.70N MIN. 40P : 19.60N MIN. 50P : 24.50N MIN. 60P : 29.40N MIN. 70N : 34.30N MIN.
COPLANARITY	0.10 MAX.
PRODUCT SPECIFICATION	PRS-2514
TEST REPORT	TR-18067 (PLUG:20877-0**T-0#, RECEPTACLE:20879-0**E-01) TR-18088 (PLUG:20877-0**T-0#, RECEPTACLE:20879-0**E-02) TR-24001 (PLUG:20877-0**T-0#, RECEPTACLE:20879-0**E-11) TR-24002 (PLUG:20877-0**T-1#, RECEPTACLE:20879-0**E-01) TR-24003 (PLUG:20877-0**T-1#, RECEPTACLE:20879-0**E-02) TR-24004 (PLUG:20877-0**T-1#, RECEPTACLE:20879-0**E-11)
PACKING STANDARD	PST-18043
INSTRUCTION MANUAL	HIM-18033
APPEARANCE CRITERIA No.	QLS-A***

※Only the single-hook pull jig is permitted for 70P.  
The dual-hook pull jig is not allowed for 70P.

Rev.18

# Custom Connectors Available

## RF Connectors

MHF® series

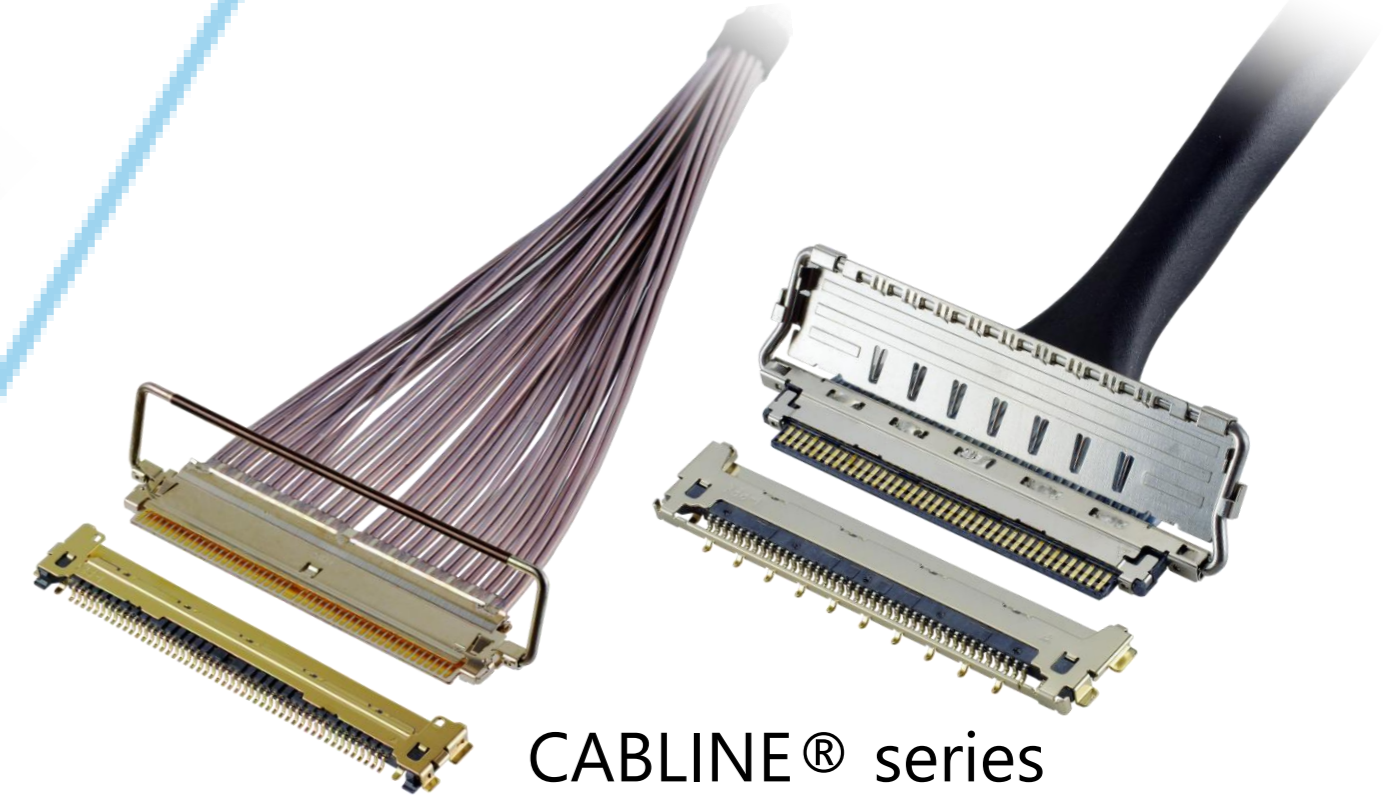

CABLINA® series

## Micro-Coaxial/Twinaxial Connectors



## Wire-to-Board Connectors/Terminals

AP series

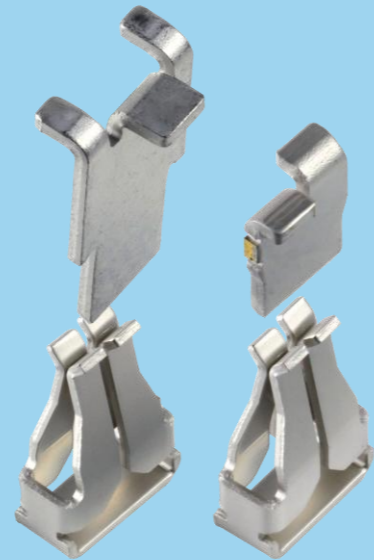

ISH® series

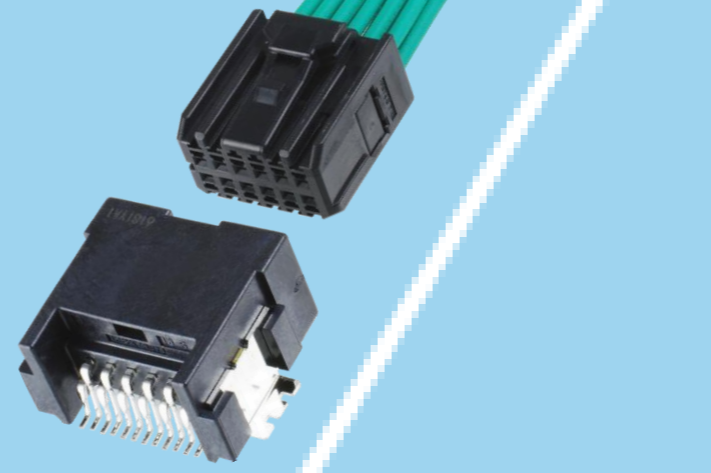

NOVASTACK® series



## Board-to-Board Connectors



## I/O Connectors

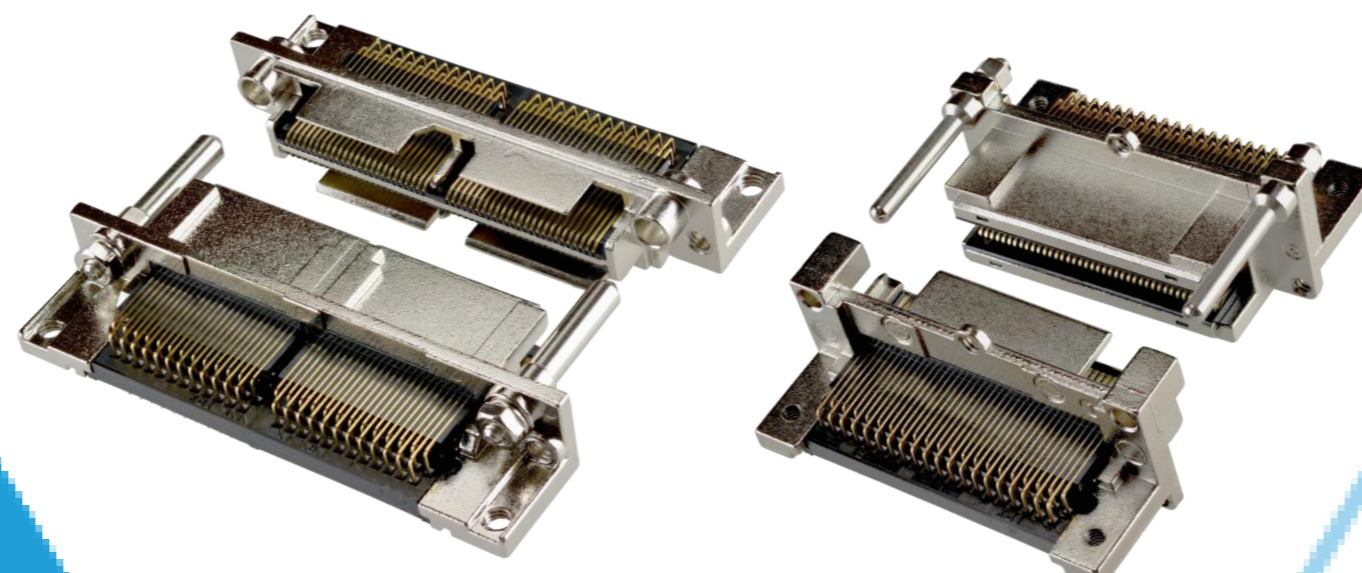

MINIDOCK™ series

MINIFLEX® series EVAFLEX® series

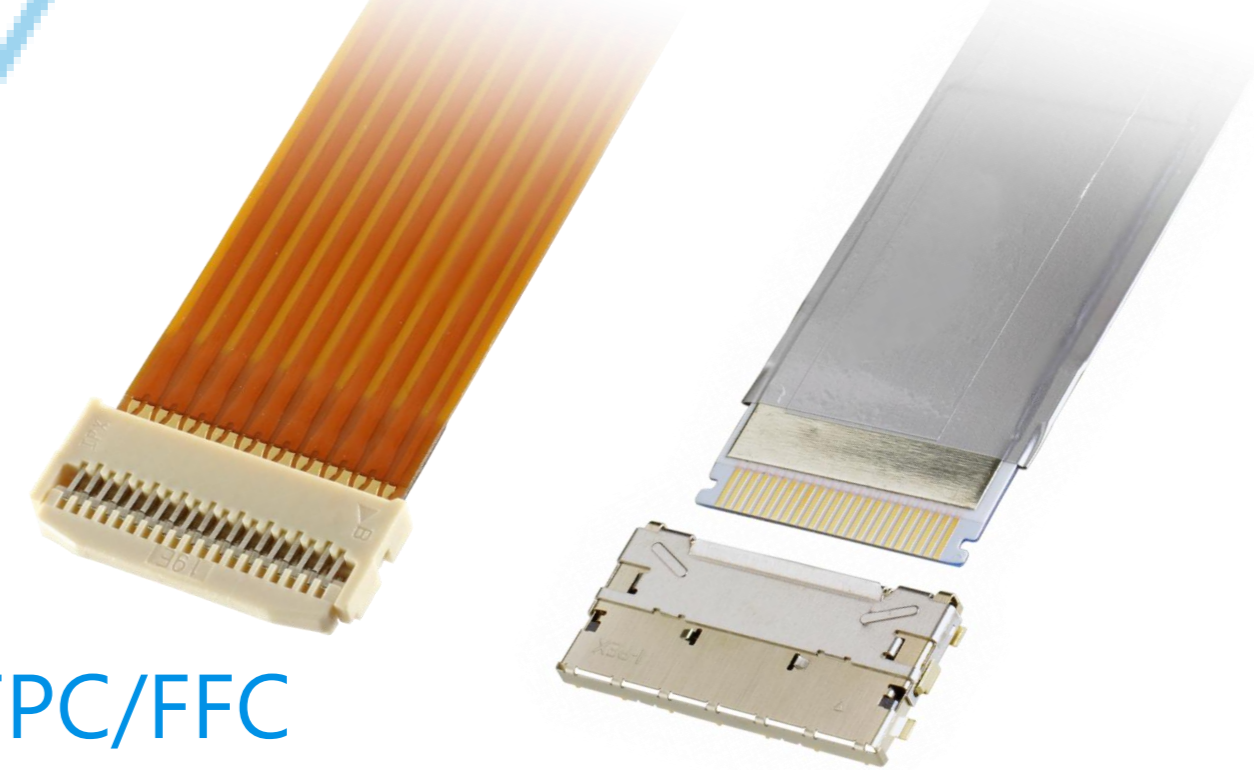

## FPC/FFC Connectors



Inquiry



I-PEX, MHF, CABLINE, NOVASTACK, ISH, IARPB, MINIFLEX, EVAFLEX, MINIDOCK, i-Fit and ZenShield are registered trademarks of I-PEX Inc. Please note that the contents in the catalog might be changed without prior notification. I-PEX Inc. assumes no responsibility for any inaccuracies or obligation to update information on these documents. Please be sure to read and understand the latest "Precautions for Use" and "Instruction Manual" before you use our products. We shall not be responsible for any defects, damages or troubles in case you use our products without following the precautions for use. Please feel free to contact our sales representatives when you use our products for any applications that require very high reliability and safety, or that relate to human life (ex. nuclear power control, aerospace, transportation, medical equipment, safety equipment etc.).

Contact your sales representative or more detailed information.

[www.i-pex.com](http://www.i-pex.com)



# I-PEX

© I-PEX Inc. 2026  
All rights reserved