



Buchanan

TE Internal #: 1546477-2

Dual Barrier, Wire-to-Wire, 2 Position, 11 mm [.433 in] Centerline, 2 Row, Operating Voltage 300 V, 22 – 14 AWG Wire Size, Barrier Strips

[View on TE.com >](#)

Connectors > Terminal Blocks & Strips > Barrier Strips

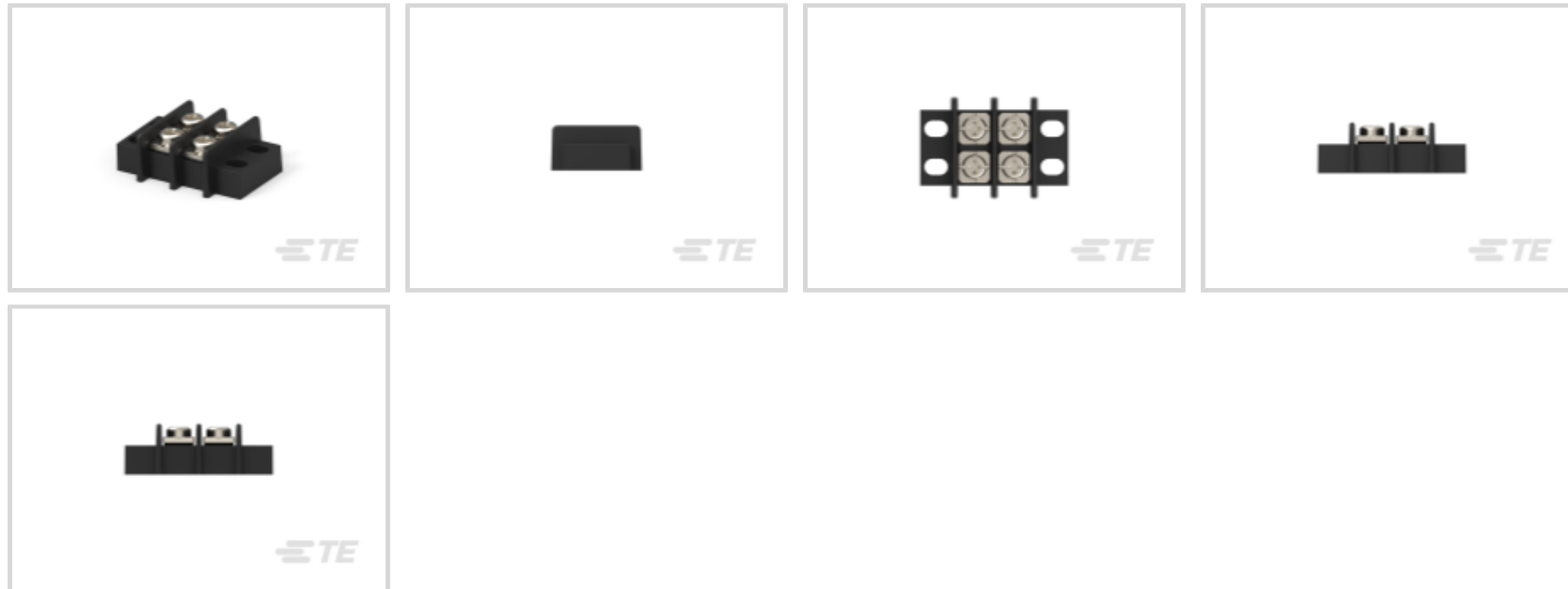

Barrier Strip Style: **Dual Barrier**

Connector System: **Wire-to-Wire**

Number of Positions: **2**

Centerline (Pitch): **11 mm [.433 in]**

Number of Rows: **2**

Features

Body Features

Barrier Strip Style	Dual Barrier
Quick Connect Tab Plating Material	Tin
Primary Product Color	Black
Product Orientation	Vertical

Product Type Features

Connector System	Wire-to-Wire
Connector & Contact Terminates To	Wire & Cable
Block Style	Non-Feed Through

Configuration Features

Number of Positions	2
Number of Rows	2
Number of Levels	1

Housing Features

Centerline (Pitch)	11 mm [.433 in]
--------------------	-----------------



Housing Material	Thermoplastic
------------------	---------------

Electrical Characteristics

Operating Voltage	300 V
-------------------	-------

Dimensions

Wire Size	.3 – 2 mm ²
-----------	------------------------

Product Length	40.9 mm[1.61 in]
----------------	------------------

Contact Features

Contact Current Rating (Max)	25 A
------------------------------	------

Contact Base Material	Brass
-----------------------	-------

Mechanical Attachment

Connector Mounting Type	Panel Mount
-------------------------	-------------

Top Termination Type	Wire Clamp Combo Head
----------------------	-----------------------

Mounting Options	End Mounting Ears
------------------	-------------------

Screw Plating Material	Nickel
------------------------	--------

Thread Size	6-32
-------------	------

Screw Material	Steel
----------------	-------

Usage Conditions

Operating Temperature Range	-40 – 120 °C[-40 – 248 °F]
-----------------------------	----------------------------

Other

EU RoHS Compliance	Compliant
--------------------	-----------

EU ELV Compliance	Compliant
-------------------	-----------

Operation/Application

Circuit Application	Power
---------------------	-------

Industry Standards

UL Flammability Rating	UL 94V-0
------------------------	----------

Packaging Features

Packaging Method	Package
------------------	---------

Packaging Quantity	200
--------------------	-----

Product Compliance

[For compliance documentation, visit the product page on TE.com>](#)



EU RoHS Directive 2011/65/EU	Compliant
EU ELV Directive 2000/53/EC	Compliant
China RoHS 2 Directive MIIT Order No 32, 2016	No Restricted Materials Above Threshold
EU REACH Regulation (EC) No. 1907/2006	Current ECHA Candidate List: JUNE 2024 (241) Candidate List Declared Against: JAN 2023 (233) Does not contain REACH SVHC
Halogen Content	Low Halogen - Br, Cl, F, I < 900 ppm per homogenous material. Also BFR/CFR/PVC Free
Solder Process Capability	Wave solder capable to 265°C

Product Compliance Disclaimer

This information is provided based on reasonable inquiry of our suppliers and represents our current actual knowledge based on the information they provided. This information is subject to change. The part numbers that TE has identified as EU RoHS compliant have a maximum concentration of 0.1% by weight in homogenous materials for lead, hexavalent chromium, mercury, PBB, PBDE, DBP, BBP, DEHP, DIBP, and 0.01% for cadmium, or qualify for an exemption to these limits as defined in the Annexes of Directive 2011/65/EU (RoHS2). Finished electrical and electronic equipment products will be CE marked as required by Directive 2011/65/EU. Components may not be CE marked. Additionally, the part numbers that TE has identified as EU ELV compliant have a maximum concentration of 0.1% by weight in homogenous materials for lead, hexavalent chromium, and mercury, and 0.01% for cadmium, or qualify for an exemption to these limits as defined in the Annexes of Directive 2000/53/EC (ELV). Regarding the REACH Regulation, the information TE provides on SVHC in articles for this part number is based on the latest European Chemicals Agency (ECHA) 'Guidance on requirements for substances in articles' posted at this URL: <https://echa.europa.eu/guidance-documents/guidance-on-reach>

Compatible Parts



Customers Also Bought

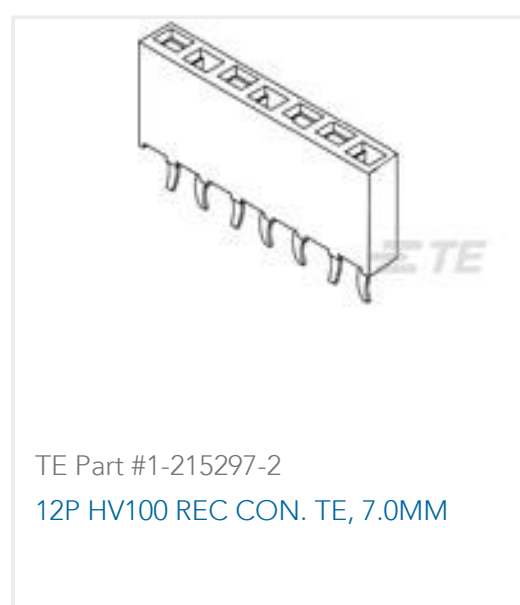



Documents

Product Drawings

[2P .433" DR BARRIER,W/WASHER](#)

English

CAD Files

[3D PDF](#)

3D

Customer View Model

[ENG_CVM_CVM_1546477-2_F.2d_dxf.zip](#)

English

Customer View Model

[ENG_CVM_CVM_1546477-2_F.3d_igs.zip](#)

English

Customer View Model

[ENG_CVM_CVM_1546477-2_F.3d_stp.zip](#)

English

By downloading the CAD file I accept and agree to the [Terms and Conditions](#) of use.

Datasheets & Catalog Pages

[BUCHANAN TERMINAL BLOCKS CATALOG - BARRIER STRIPS](#)

English

[1-1773458-2_BARRIER_STRIPS_QUICK_REFERENCE_GUIDE](#)

English