

High Current Power Connector for Internal Automotive Connection, Heat Resistant up to 125°C

HVH-280 Series

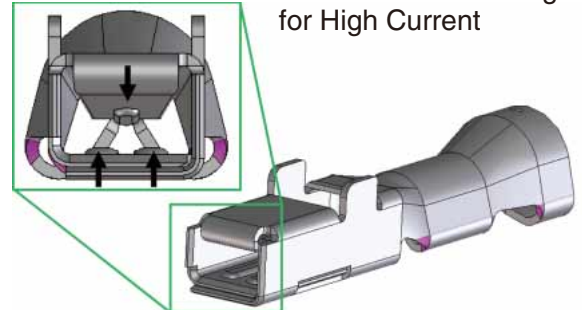

● High Current Terminal



3-Point Contact Design for High Current

Fig.1

■ Features

1. **Rated Current : 30A,**
Rated Voltage : 600V AC/DC

2. **High Heat Resistance**

Suitable for use in 125°C environments.

3. **High Reliability 3-Point Contact Design**

High contact pressure design enables high current capacity.

4. **High Vibration Resistance**

The cable sheath is firmly secured to reduce cable runout during vibration.

5. **Lock Designed for Easy Operation**

Stroke depth and long lock arm allow workers to operate the lock with ease.

6. **Clear Tactile Click and Stable Connection**

Clear tactile click during mating and firm lock supports reliable mating operation.

7. **Crimp Terminal Insertion Ensured**

Retainer prevents incomplete insertion of crimp terminals.

8. **Prevents Mis-Insertion**

Designed to prevent reversed insertion of terminals and reversed connector insertion during mating.

● 600V Rated Voltage

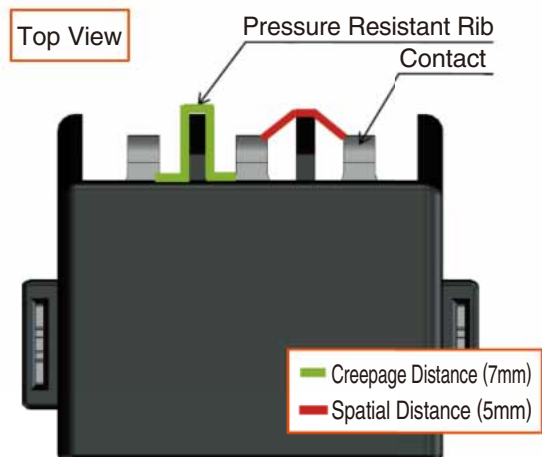

Fig.2

● Incomplete Insertion Prevention and High Vibration Resistance

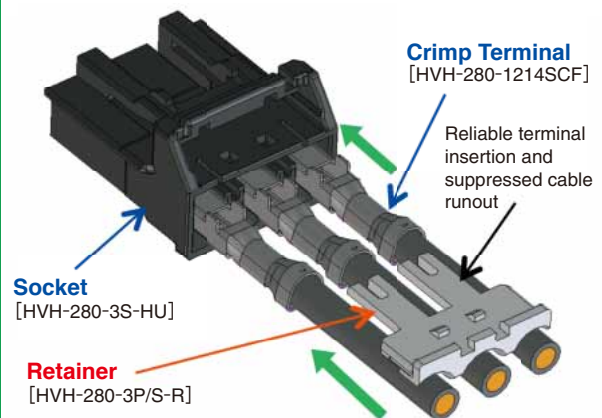

Fig.3

Product Specifications

Ratings	Rated Current	30A (Note 1)	Operating Temperature	-40°C to +125°C
			Storage Temperature Range	-10°C to +60°C (Note 2)
	Rated Voltage	600V AC/DC	Storage Humidity Range	Relative humidity 85% or less (No condensation)

Items	Specifications	Conditions
1. Contact Resistance	100MΩ Min	Measured at 1000V DC
2. Withstanding Voltage	There shall be no dielectric breakdown or flashover.	2200V AC applied for 1minute.
3. Voltage Drop	5mΩ Max	Measured at A (Cable cross-sectional area×5) DC
4. Connector Insertion Force	45N Max. No damage, strain or deformation to components.	Inserted at a constant speed of 50mm/min Max.
5. Connector Unmating Force	75N Max. No damage, strain or deformation to components.	Removed at a constant speed of 50mm/min Max.
6. Connector Retention Force	110N Min.	Removed at a constant speed of 50mm/min Max.
7. Vibration/ Mechanical Shock	Voltage Drop : 5mΩ Max. Contact Resistance : 100MΩ Min. No electrical discontinuity of 1μs or more. No damage, strain or deformation to components.	[Vibration] Random vibration frequency 5 to 1000Hz (Acceleration/1.81grms) 8 hour test in each of the three directions under the above conditions [Shock] Acceleration of 35G, 10 times in both directions of the 3 axes
8. Thermal Shock	Voltage Drop : 5mΩ Max. Contact Resistance : 100MΩ Min. No electrical discontinuity of 1μs or more. Withstanding Voltage:No dielectric breakdown or flashover. No damage, strain or deformation to components.	Temperature -40°C → Room temperature → 125°C → Room temperature Time : 30 → 5 → 30 → 5 minutes for 100 cycles
9. Temperature Cycle	Retention force between contact and connector : 50N. Min. Voltage Drop : 5mΩ Max. Contact Resistance : 100MΩ Min. Withstanding Voltage : No dielectric breakdown or flashover. No damage, strain or deformation to components.	Left for 40 cycles at a temperature of -40 to 125°C, and relative humidity of 80 to 100%
10. High Temperature Storage	Voltage Drop : 5mΩ Max. Contact Resistance : 100MΩ Min. Withstanding Voltage : No dielectric breakdown or flashover. No damage, strain or deformation to components.	Left at a temperature of 125°C for 1008 hours.

Note 1 : The rating current depends on operating temperature and cable used. Please contact a Hirose Sales Office for inquiries.

Note 2 : This storage temperature is for long-term storage of unused products.

Materials/Finish

Component	Part	Material	Finish	UL Standard
Header	Housing	PBT Resin	Black	UL94V-0
	Crimp Terminal	Copper Alloy	Tin Plating	—
	Retainer	PBT Resin	Dark Gray	UL94V-0
Socket	Housing	PA Resin	Black	UL94V-0
	Terminal	Copper Alloy	Tin Plating	—
	Solder Tabs	Phosphor Bronze	Tin Plating	—

Product Number Structure

Refer to the chart below when determining the product specifications from the product number. Please select from the product numbers listed in this catalog when placing orders.

Connector

HVH-280 – 3 P 6.5 DS

① ② ③ ④ ⑤

Terminal

HVH-280 – 1214 SCF

⑥ ⑦

① Series Name	: HVH-280
② No. of Pos	: 2, 3
③ Connector Type	P : Header S : Socket
④ Contact Pitch	: 6.5mm
⑤ Termination Form	DS : Right Angle DIP HU : Housing
⑥ Applicable Cable Size	1214 : 12 to 14 AWG
⑦ Form Type/Packaging	SCF Socket Contact/Reel

Product Configurations

Header

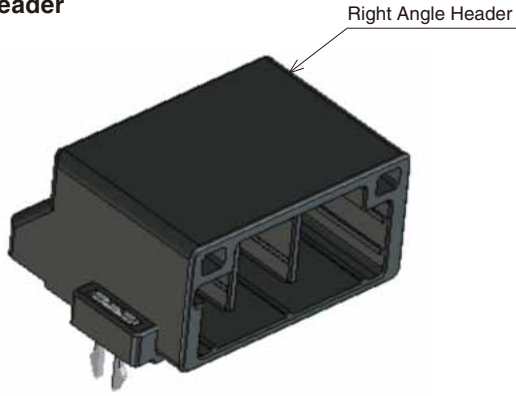

Socket

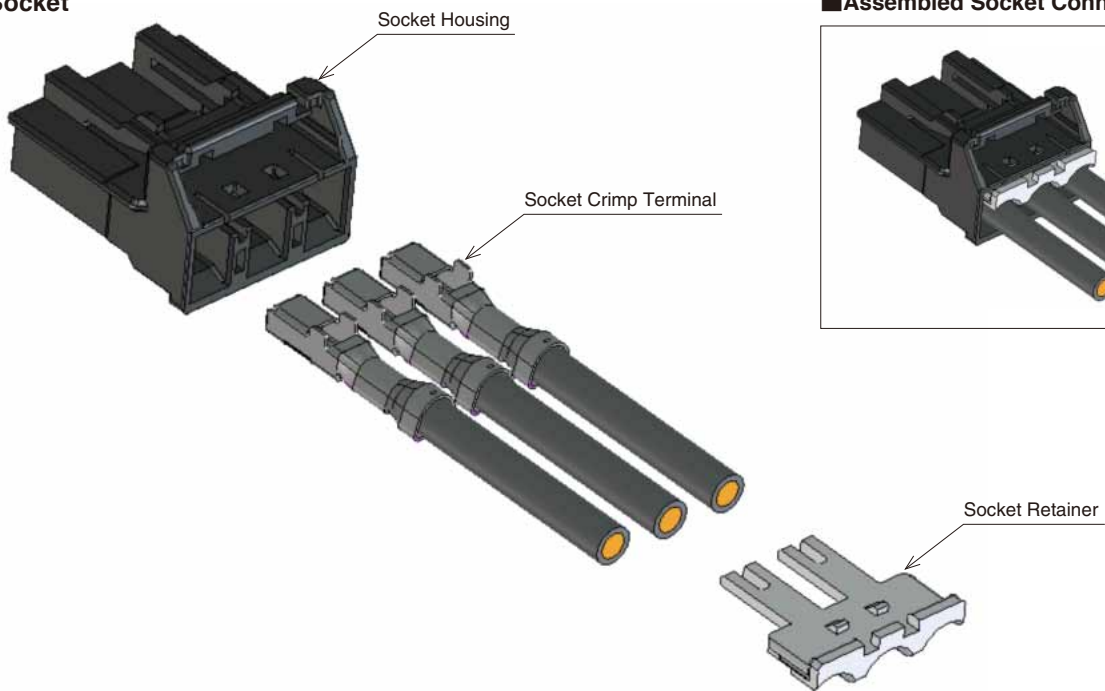

Assembled Socket Connector



HVH-280 Series Mating Table

Header		Socket	
HVH-280 *pos. Header (Board Side)	Configuration Product Name	HVH-280 *pos. Socket	Configuration Product Name
	HVH-280-*P-6.5DS		HVH-280-*S-HU
			HVH-280-*P/S-R
			HVH-280-1214SCF

Right Angle Header

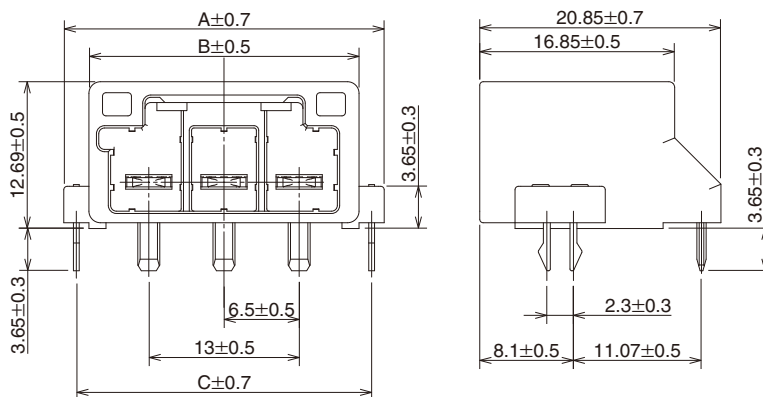

Part No.	HRS No.	No. of Pos.	Number of tray packages	Finish	A	B	C
HVH-280-2P-6.5DS	778-0703-0	2	700	Tin Plating	21.2	16.85	19.03
HVH-280-3P-6.5DS	778-0700-0	3	560	Tin Plating	27.7	23.35	25.53

Note : Tray packages must be ordered in multiples of 560.

Socket Housing

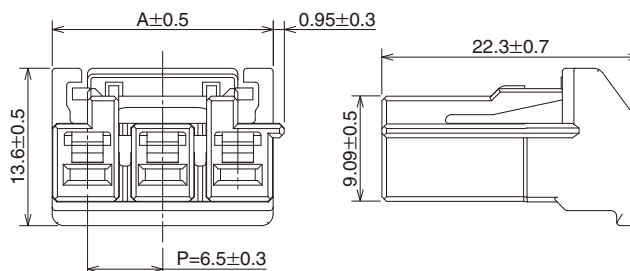

Part No.	HRS No.	No. of Pos.	A
HVH-280-2S-HU	778-0704-0	2	12.6
HVH-280-3S-HU	778-0701-0	3	19.1

Note : The product is sold in packs (100 pieces per pack) so please order based on number of packs.

Nov. 1. 2024 Copyright 2024 HIROSE ELECTRIC CO., LTD. All Rights Reserved.

Socket Retainer

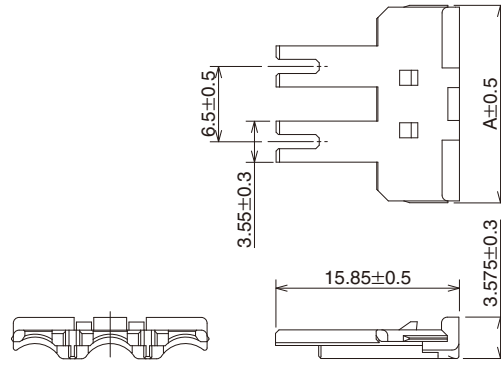

Part No.	HRS No.	No. of Pos.	A
HVH-280-2P/S-R	778-0705-0	2	10.565
HVH-280-3P/S-R	778-0702-0	3	17.065

Note : The product is sold in packs (100 pieces per pack) so please order based on number of sets.

Socket Crimp Terminal

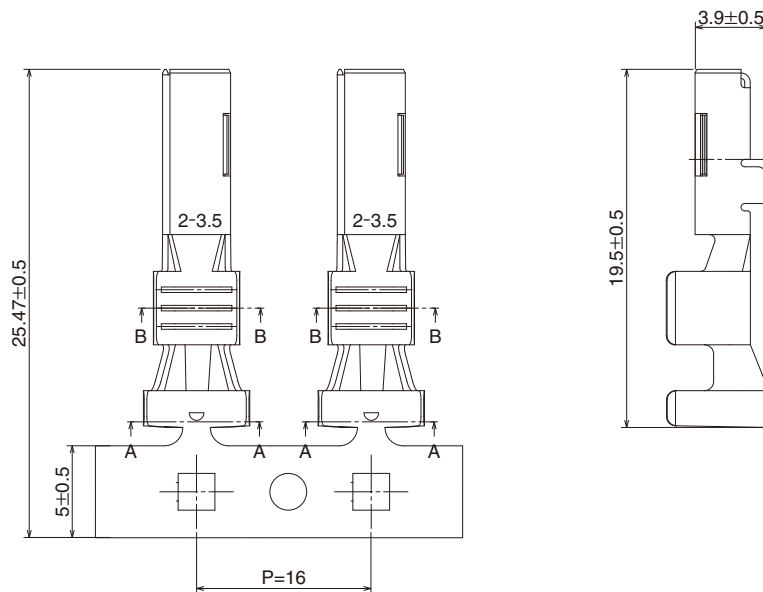

Part No.	HRS No.	Type	Amount	Finish
HVH-280-1214SCF	778-0502-0	Reel Terminal	1,700 pcs/reel	Tin Plating

Note 1 : The applicable cable's conductor is a tin plated soft copper wire.

Note 2 : Any problems that occur from using tools other than those specified by Hirose are not covered by warranty.

Note 3 : The applicable cable size is 12 to 14 AWG (2 to 3.5mm²).

Applicable Crimp Tool

Type	Part No.	HRS No.	Applicable Contact
Applicator	AP105-HVH-280-1214S	901-5244-0	HVH-280-1214SCF

Note 1 : Any problems that occur from using tools other than those specified by Hirose are not covered by warranty.

Note 2 : Crimping work shall be conducted in accordance with the "Crimping Standard" and "Crimping Conditions Table".

◆ How to Extract the Terminal

- Terminal Extraction Tools : Precise screwdriver (flathead screwdriver)
- Applicable crimp terminals : HVH-280-1214SCF
- Operation Method

● Repair Method

To repair, press the mold lance with the terminal extraction tool in the direction shown in the diagram below. While pressing extract the terminal. Make sure not to deform the terminal lock or contact part.

Caution : Do not push the terminal locking feature or contact. It may lead to deformation or damage to the housing and other parts. When damaged, please replace it with a new one.

HVH-280-1214SCF

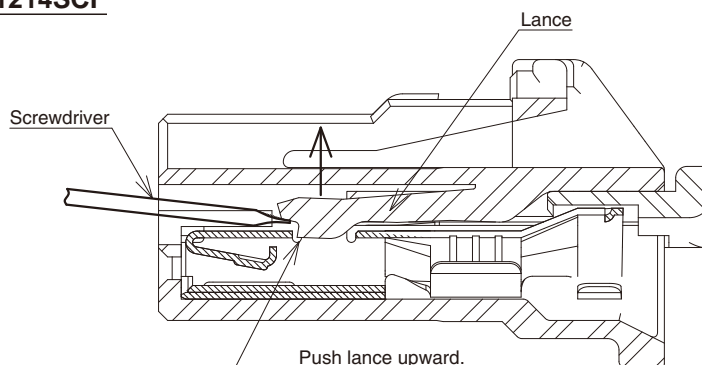

◆ Usage Precautions

1. Pulling out the connector with force may result in damage. If it is difficult to pull out, lightly push it once and then operate the lock to pull it out.
2. When inserting or extracting the terminal, always disconnect from the power source first.
3. Do not touch the terminals while the power is on since it is very dangerous.
4. Contact a sales representative for harness instructions and handling manuals.
5. Do not perform insertion or extraction with a live wire. (Live wire insertion/extraction refers to inserting/extracting while electricity is running)

◆ Usage Environment

Please consult with your Hirose Electric sales representative if your system environmental conditions repeat high and low temperatures.

