

# 0.5mm pitch Board-to-Board connectors with floating structure

## FX22 Series



Floating range:  $\pm 0.6\text{mm}$

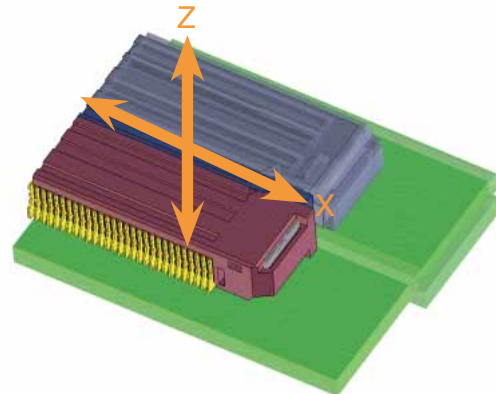

Fig.1

### ■ Features

#### 1. The floating design

Structure provides for an mis-alignment of  $\pm 0.6\text{mm}$  in both X and Z directions in 0.5mm pitch product. (Fig.1)

#### 2. A double-beam contact structure

The independent double beam contact structure provides self-cleaning feature, ensuring high-contact reliability. (Fig.2)

#### 3. Current capacity : 0.7A/pin

The FX22 features a high current capacity of 0.7A/pin relative to its 0.5mm pitch.

#### 4. Effective mating length of 1.5mm

The signal contacts have effective contact lengths of 2.0mm and 1.5mm, which provide sufficient margin on the mating stroke.

#### 5. Low connector height

The compact structure and low connector height fits well into areas as small as 5mm spacing, allowing for higher density mounting. (Fig.3)

#### 6. Self-alignment and self-guiding structure

Guide posts enable self-alignment and ensure a secure connection.

A double-beam contact structure

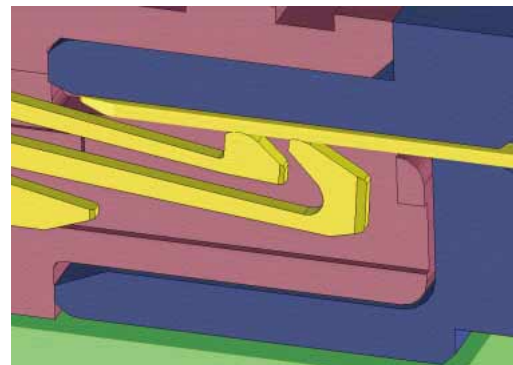
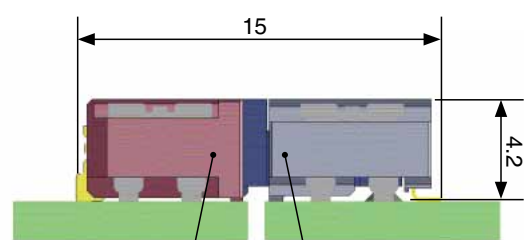

Fig.2

Mated connector dimensions



Receptacle :  
FX22-\*\*\*S-0.5SH

Header :  
FX22-\*\*\*P-0.5SH

Fig.3

## Product Specifications

Ratings	Rated current 0.7A Rated voltage AC 50V	Operation temperature range : -55 to 85°C (Note 1) Storage temperature range : -10 to 60°C (Note 2)
Items	Specifications	Conditions
1. Contact resistance	70mΩ max.	100mA (DC or 1000Hz)
2. Insulation resistance	100MΩ min.	100V DC.
3. Withstanding voltage	No flashover or breakdown.	150V AC for 1min.
4. Mating Cycles	80mΩ max.	50 times insertions and extractions.
5. Vibration resistance	No electrical discontinuity for more than 1μs.	Frequency : 10 to 55 to 10Hz, approx 5 min Single amplitude : 0.75mm, 10 cycles for 3 axial directions.
6. Shock resistance	No electrical discontinuity for more than 1μs.	490m/s <sup>2</sup> , duration of pulse 11ms at 3 times for 3 both axial directions.
7. Moisture resistance	80mΩ max Insulation resistance : 100MΩ min.	Exposed at 40 ± 2°C, 90~95%, 96h.
8. Temperature cycle	80mΩ max Insulation resistance : 100MΩ min.	Temperature : -55 → 85°C Time : 30 → 30 min, for 5 cycles

Note 1 : Includes temperature rise caused by current flow.

Note 2 : The term "storage" here refers to products stored for a long period prior to board mounting and use.

## Materials / Finish

Part	Material		Finish	UL standard
Insulator	Header	PA	Black	UL94V-0
	Receptacle	LCP		
Contact	Header	Copper alloy	Contact area : Gold plated Mounting area : Gold plated	—————
	Receptacle			
Metal fitting	Brass		Tin plated	—————

## Product Number Structure

Refer to the chart below when determining the product specifications from the product number.

Please select from the product numbers listed in this catalog when placing orders.

### Right-angle receptacle

**FX22 - 80 S - 0.5 SH**

①      ②   ③      ④      ⑤

### Right-angle header

**FX22 - 80 P - 0.5 SH**

①      ②   ③      ④      ⑤

① Series name :	FX22
② Number of contacts	
③ Connector type S : Receptacle type P : Header type	
④ Contact pitch :	0.5mm
⑤ Product style SH :	Right-angle type

## Right-angle receptacle

[ FX22-\*\*\*S-0.5SH ]

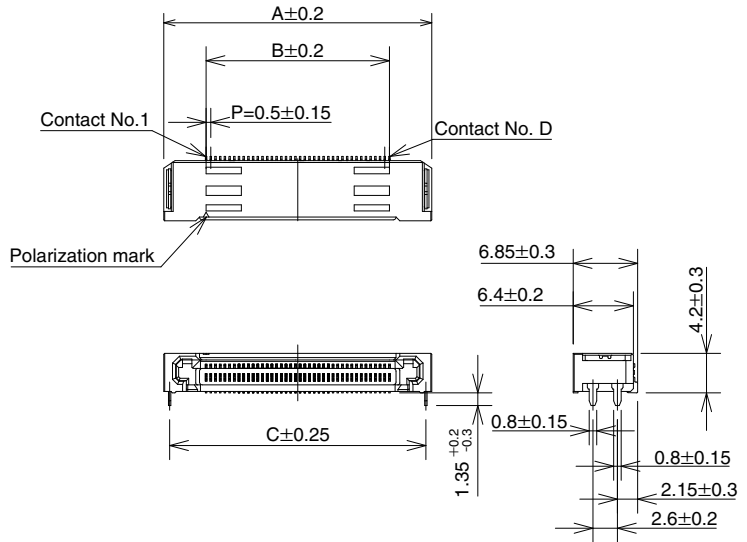

Unit : mm

Part No.	HRS No.	No. of contacts	A	B	C	D
FX22-40S-0.5SH	572-3100-6	40	28.5	19.5	27.25	40
FX22-50S-0.5SH	572-3101-9	50	33.5	24.5	32.25	50
FX22-60S-0.5SH	572-3102-1	60	38.5	29.5	37.25	60
FX22-80S-0.5SH	572-3103-4	80	48.5	39.5	47.25	80

## Right-angle header

[ FX22-\*\*\*P-0.5SH ]

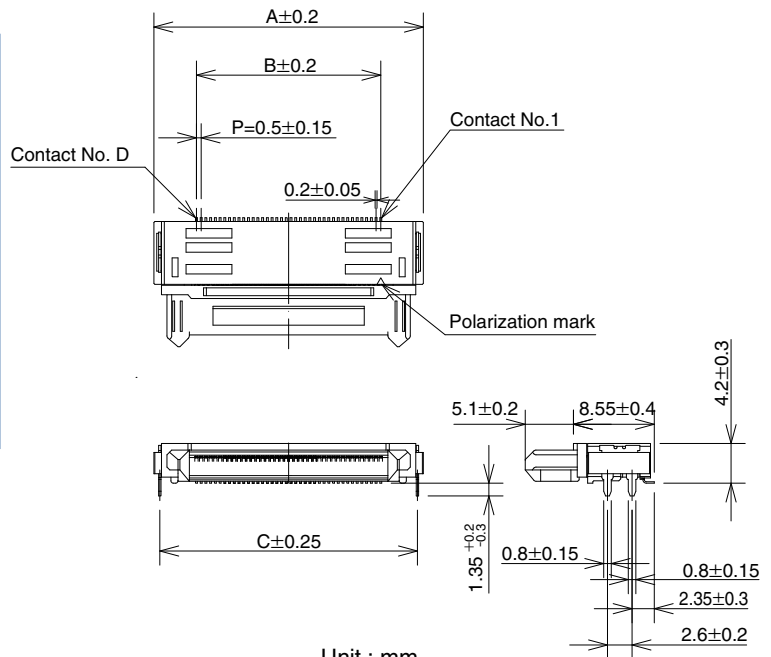

Unit : mm

Part No.	HRS No.	No. of contacts	A	B	C	D
FX22-40P-0.5SH	572-3001-4	40	28.5	19.5	27.25	40
FX22-50P-0.5SH	572-3002-7	50	33.5	24.5	32.25	50
FX22-60P-0.5SH	572-3003-0	60	38.5	29.5	37.25	60
FX22-80P-0.5SH	572-3004-2	80	48.5	39.5	47.25	80

## ◆ Recommended PCB layout dimensions (PCB thickness : t = 1.6mm / Stencil thickness : t = 0.12mm)

### ● Right-angle receptacle [ FX22-\*\*-S-0.5SH ]

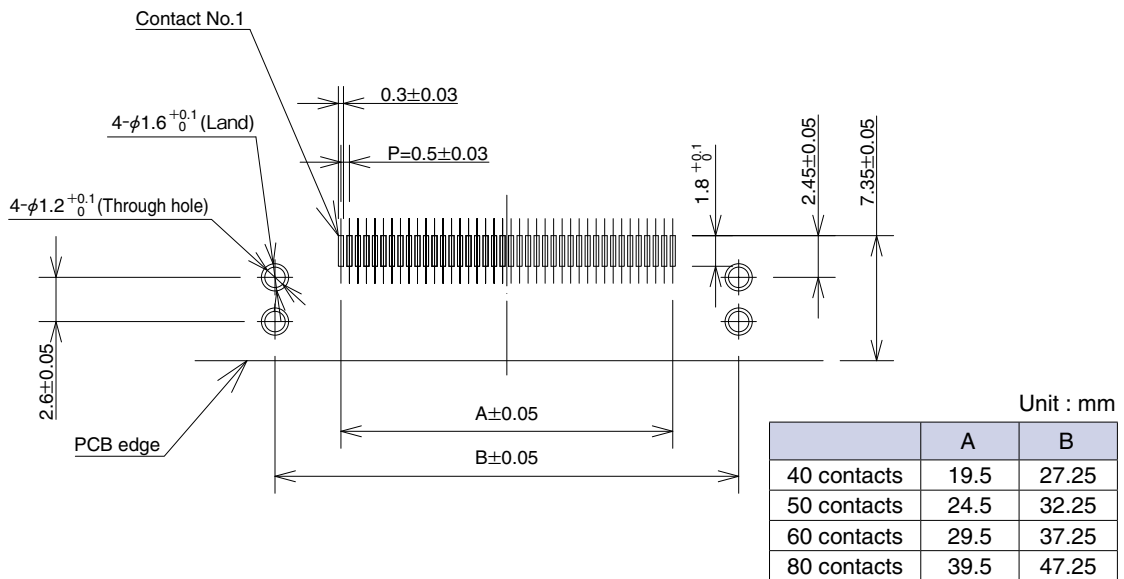

### ● Right-angle header [ FX22-\*\*-P-0.5SH ]

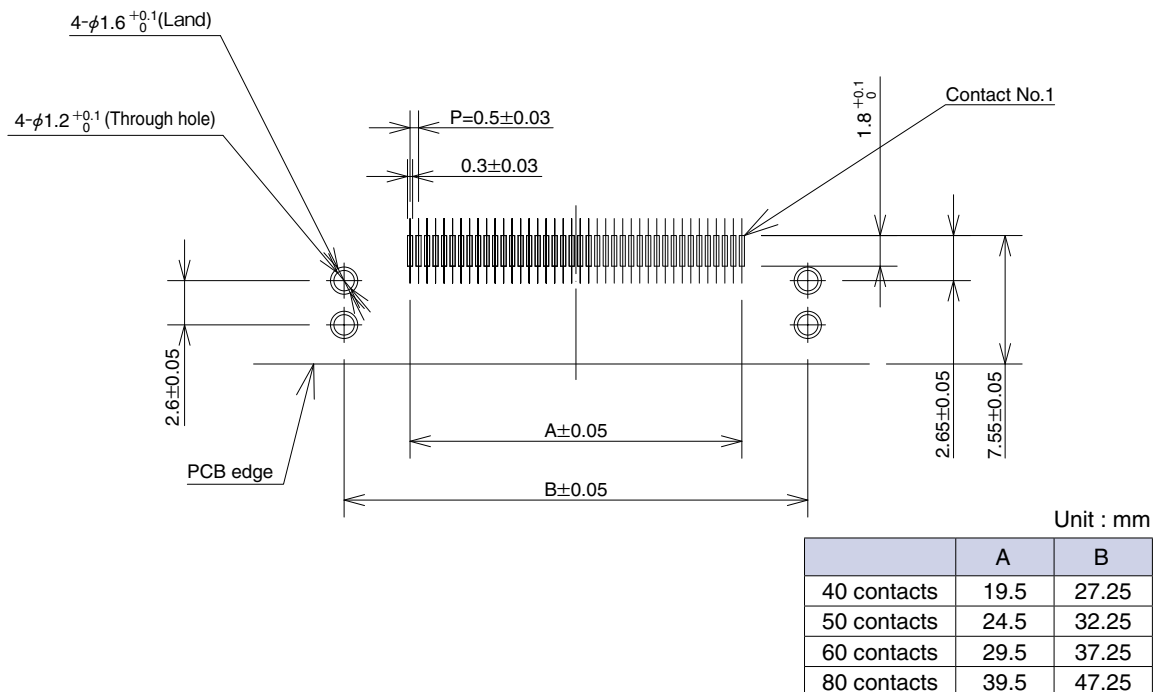

## ◆ Embossed tape packaging dimensions

### ● Right-angle receptacle

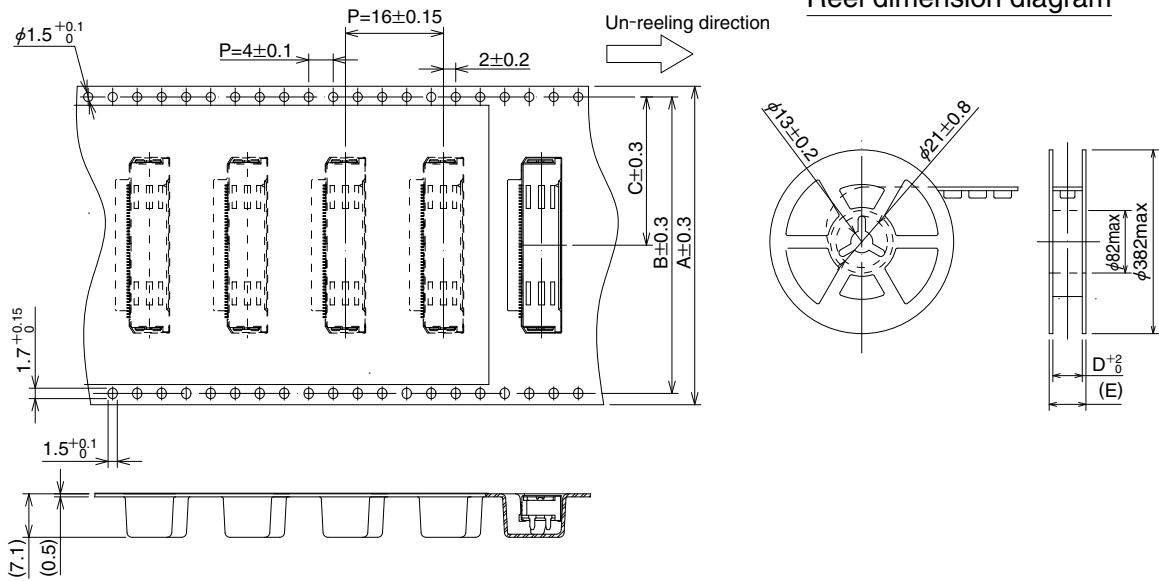

Unit : mm

Part No.	A	B	C	D	E
FX22-40S-0.5SH	44	40.4	20.2	44.4	50.4
FX22-50S-0.5SH	56	52.4	26.2	56.4	62.4
FX22-60S-0.5SH					
FX22-80S-0.5SH	72	68.4	34.2	72.4	78.4

(00) Embossed packaging : 700pcs/reel

### ● Right-angle header

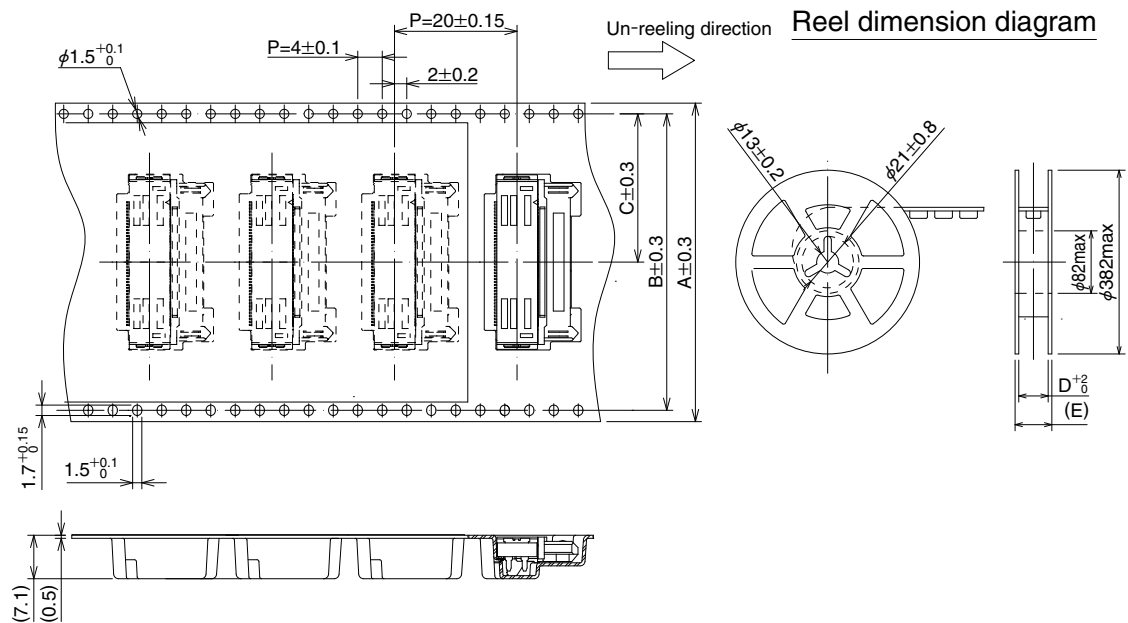

Unit : mm

Part No.	A	B	C	D	E
FX22-40P-0.5SH	44	40.4	20.2	44.4	50.4
FX22-50P-0.5SH	56	52.4	26.2	56.4	62.4
FX22-60P-0.5SH					
FX22-80P-0.5SH	72	68.4	34.2	72.4	78.4

(00) Embossed packaging : 500pcs/reel

## ◆ Recommended Temperature Profile

● This temperature profile is based on the setting conditions shown below and is for reference only. For individual applications, the temperature profile may vary in accordance with the conditions. Please confirm the profile before mounting.

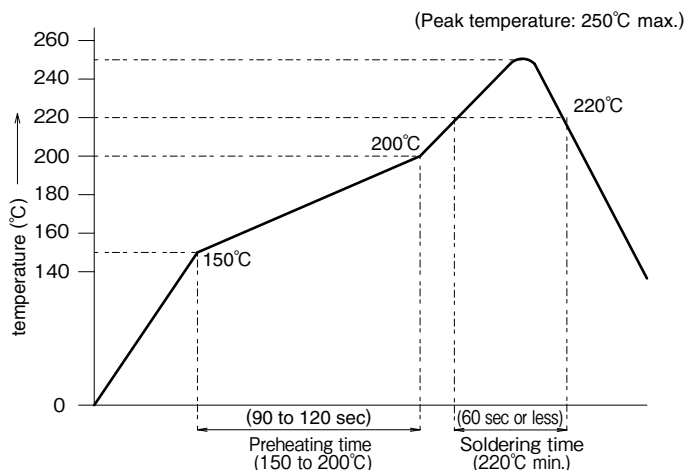

<Applicable conditions>

Test PCB Size : 110×40×1.6mm

Material : Glass epoxy

Solder composition : Sn-3Ag-0.5Cu

Flux contained amount : 11wt%

Metal mask thickness : 0.12mm

Note 1 : This temperature profile shows recommended values.

Note 2 : The number of reflow processes should be no more than two.

Note 3 : Temperature profile may differ slightly depending on the type and amount of solder cream used.

## ◆ Cleaning conditions

### ● Organic Solvent-based cleaning

Solvent type	Room temperature cleaning	Heated cleaning
IPA (Isopropyl alcohol)	Yes	Yes

### ● Water based cleaning

When using water based cleaning agents (including terpene, and alkali saponifiers), pay special attention to how the cleaning agent will react to specific metals and plastics before selecting one of them. Various cleaning agent manufacturers publish reaction tables for their cleaning agents. Do not leave connectors with moisture remaining on them.

### ● Caution when washing

The electrical performance may deteriorate if the flux or cleaning detergent is left on the connector after the cleaning. Check thoroughly to ensure that there is no residue left on any of the surfaces.

## ◆ Precautions

- Avoid supporting the PCB only by the connectors. Please make sure to support the PCBs with screws, bolts, or other types of anchors as the primary means of support.
- When using low profile connectors, care should be taken not to use excessive prying or rotating forces during mating/unmating operations. This could cause damage and contact failure. Please handle with care.

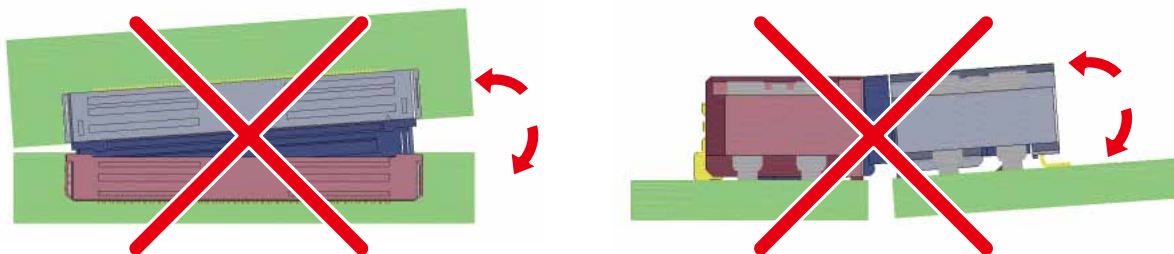

**HIROSE ELECTRIC CO.,LTD.**

2-6-3,Nakagawa Chuoh,Tsuzuki-Ku,Yokohama-Shi 224-8540,JAPAN

TEL: +81-45-620-3526 Fax: +81-45-591-3726

<http://www.hirose.com>

<http://www.hirose-connectors.com>