

WE RECOMMEND THESE CONNECTORS FOR OPTIMAL SERVICE LEVEL



- SHORT LEAD-TIMES
- LOW MOQs
- QUICK SAMPLING
- AVAILABLE AT DISTRIBUTION

Preferred Part
76383-302LF
76383-303LF
76383-304LF
76383-305LF
76383-306LF
76383-307LF
76383-308LF
76383-309LF
76383-310LF

PLATING
 3 = 0.76µm GOLD/GXT ON CONTACT AREA
 2µm TIN MIN ON TAIL
 1.27µm Ni MIN UNDERLAYER

RoHS COMPATIBLE
 SEE NOTE 7

NUMBER OF POSITIONS

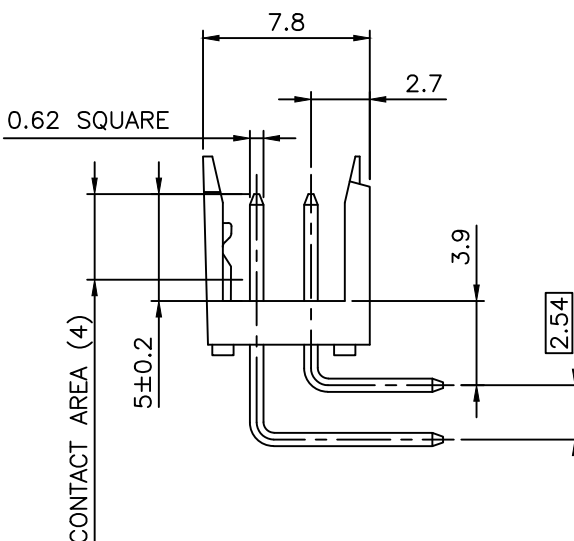
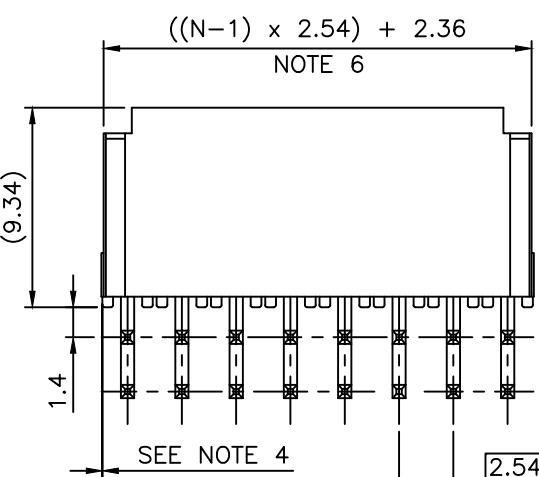
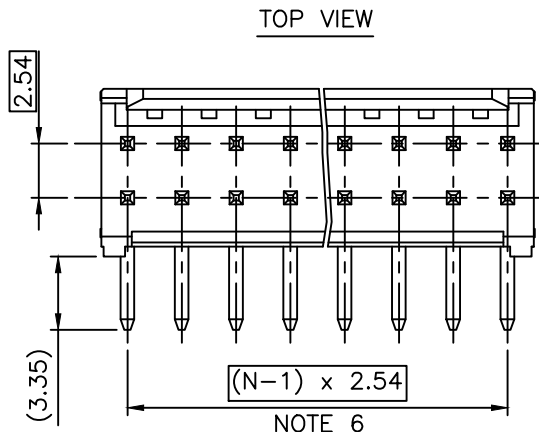

NOTES:

- BODY MATERIAL: POLYESTER 30% GLASSFILLED COLOR BLUE, FLAME RETARDANT PER UL-94 V0.
- CONTACT MATERIAL: PHOSPHOR BRONZE.
- 15N MIN PIN RETENTION IN EITHER DIRECTION
- 0.6 MAX PROTRUSION PERMITTED AT 4 PLACES
- PACKAGING :
 - POLYBAGS FROM 2 x 02 TO 2 x 06 POSITIONS
 - TUBE FROM 2 x 07 TO 2 x 36 POSITIONS
- TO DETERMINE DIMENSIONS :
 N = NUMBER OF POSITIONS PER ROW
 EXAMPLE : 8 POS N x 2.54 = 20.32mm
- RoHS COMPATIBLE PRODUCT SPECIFICATIONS
 - PLATING:
 - "LF" MEANS THE PRODUCT IS LEAD-FREE, 2µm MINIMUM MATTE TIN OVER 1.27µm MINIMUM NICKEL UNDERPLATE.
 - MANUFACTURING PROCESS COMPATIBILITY
 - THE HOUSING WILL WITHSTAND EXPOSURE TO 260°C ±5°C SOLDER BATH TEMPERATURE FOR 5 SECONDS IN A WAVE SOLDER APPLICATION WITH A 1.6mm MIN THICK CIRCUIT BOARD.
 - LABELING:
 - MEETS PACKAGING SPECS AS PER GS-14-920
 - LEGAL STATEMENT: SEE GS-47-0004
- THIS PART SERIES IS NOT INITIALLY INTENDED FOR AUTOMOTIVE APPLICATIONS. ADDITIONAL FEES ARE CHARGEABLE FOR ANY ADDITIONAL QUALIFICATION AND TEST REPORTS PERFORMED OUTSIDE THE SCOPE OF THE STANDARD PRODUCT SPECIFICATIONS.
- UNLESS OTHERWISE APPROVED BY AMPHENOL, ALL PARTS AND COMPONENTS ARE DESIGNED & BUILT ACCORDING TO AMPHENOL'S SPECIFICATIONS WHICH ARE SUBJECT TO CHANGE WITHOUT NOTICE.

mat'l. code		surface		tolerance		projection		product family	
SEE NOTES		ISO 1302		ISO 406 ISO 1101		DUBOX		DUBOX	
ltr	ecn no	dr	date	tolerances unless otherwise specified		title		title	
M	F10-0043	LMU	10.05.03	angles	linear	mm		SHR. HEADER	
N	F-21810	AMA	15.06.19					RA DR TMT	
P	F-38327	DDE	20.09.11			scale 5:1		dwg no	
R	F-54447	DDE	25.01.28	dr	D.LEGRAND	01.01.24		sheet 1 of 2	
S	F-293257	DDE	26.06.12	engr	J.COMPAGNON	01.01.24		size	
				chr	J.COMPAGNON	01.01.24		76383	
L	F08-0147	YOY	08.04.14	appd	JF.NOTTEAU	01.01.24		A3	
sheet		revision		S		A		type	
index		sheet		1		2		CUSTOMER Drawing	

Amphenol FCI
 FCIconnect.com

Copyright FCI

EXTENDED RANGE

PRODUCT NUMBER
76383-YXXLF

RoHS COMPATIBLE, SEE NOTE 7

PLATING
(AS AVAILABLE)

NUMBER OF POSITIONS PER ROW : 02 TO 36

3=0.76µm GOLD/GXT ON CONTACT AREA
2µm MIN MATTE TIN ON TAIL
1.27µm Ni MIN UNDERPLATING

4=2µm MIN MATTE TIN FULL PLATED
1.27µm Ni MIN UNDERPLATING

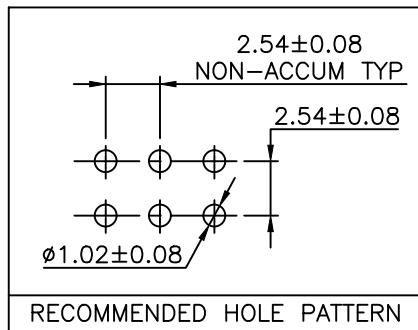

mat'l. code SEE NOTES				surface ISO 1302 ✓	tolerance ISO 406 ISO 1101	projection 	product family DUBOX
ltr	ecn no	dr	date	tolerances unless otherwise specified		mm ←→ scale 5:1	title SHR. HEADER RA DR TMT
A	F-54447	DDE	25.01.28	angles	linear		
					.x ±0.3 .xx ±0.15 .xxx ±0.05		
				dr	D.LEGRAND	01.01.24	dwg no 76383 sheet 2 of 2 size A3
				enr	J.COMPAGNON	01.01.24	
				chr	J.COMPAGNON	01.01.24	
				appd	JF.NOTTEAU	01.01.24	
sheet index	revision sheet						type CUSTOMER Drawing

Amphenol FCI
FCIconnect.com

Copyright FCI