

NO.	Name	Material	Finish	Q'TY
③ 1	Housing	PBT UL 94V-0	Black	1
2	Pin Terminal	Brass t=0.25	Gold:30u" Ni:80~120u" Sn:120~200u"	6
3	Shell	Brass t=0.4	Ni 80~120u"	1

④ Notes:

Electrical:

- Current rating: 1.5A max.
- Voltage rating: 40V max.
- Withstanding Voltage: 500V/1minute
- Contact Resistance: 30m ohms max.

⑤ ● Insulation Resistance: 100M ohms min.

Mechanical:

- Durability: 1500 Cycles
- Unmating Force: 9.8 Newton To 39.2 Newton Maximum.

Operating temperature : -55°C ~ +85°C

⑤ Salt Spray Test Time: 8H

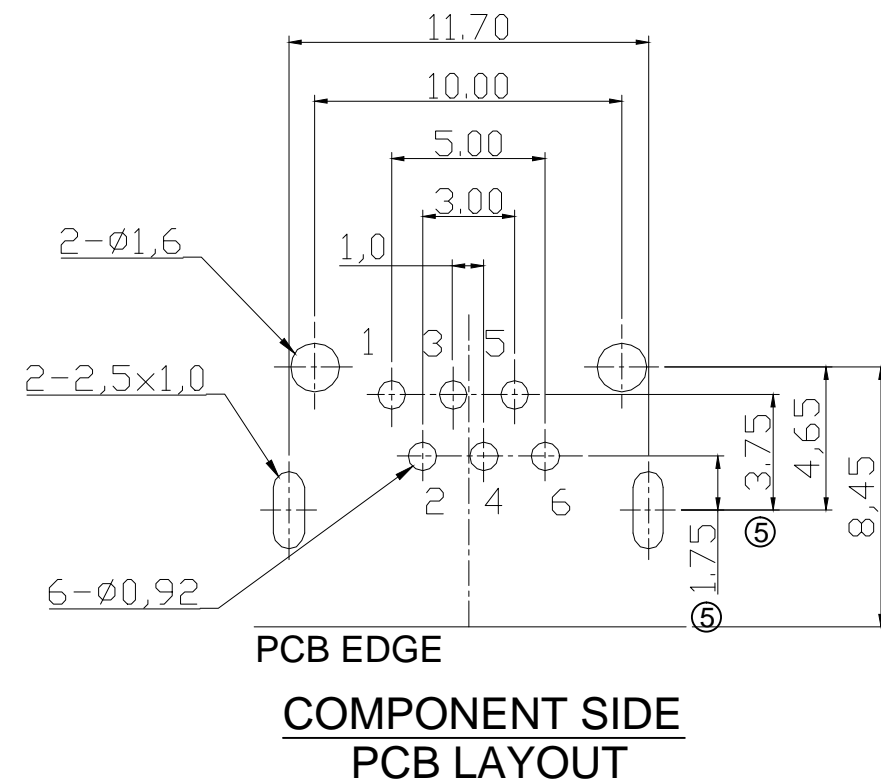
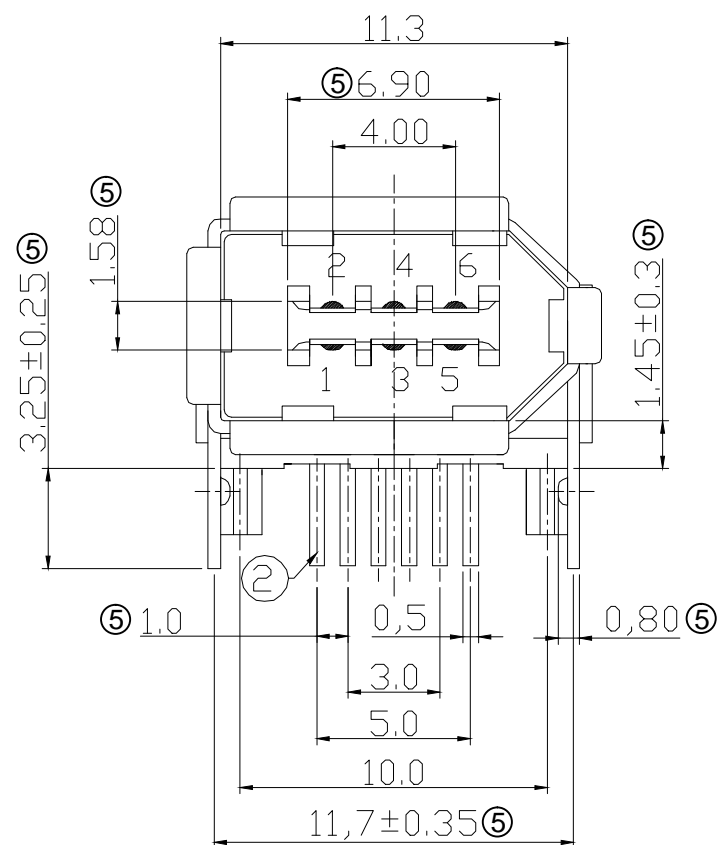
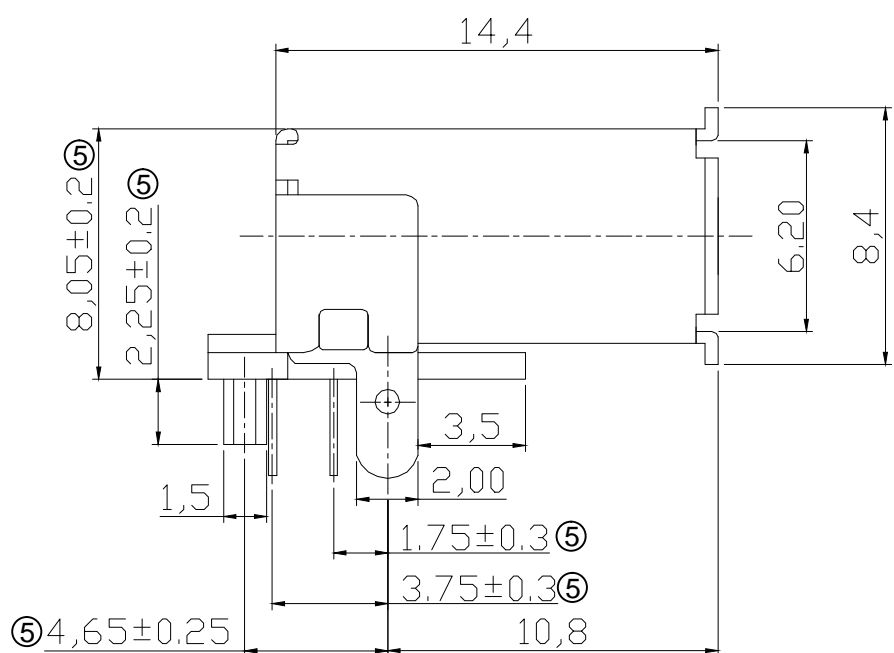

RoHS compliant
Unit: mm

⑤

Scale	Free
TOLERANCE	
X.	±0.38
.X	±0.30
.XX	±0.25
DIM	TOL
X.°	±3°
.X°	±1°
Angle	TOL

Id.	Modification	Date	Name
⑤	Update the dimension and tolerance	21.11.2025	Peter
④	Update the Notes	29.03.2019	Winnie
③	Add UL 94V-0	26.04.2018	Winnie
②	Update the new drawing	29.07.2013	Amy
①	Drawn	07.07.2009	Dean

Date: 07.07.2009
Name: Dean
Customer-No.
Date: 21.11.2025
Name: Peter
ASSMANN WSW-No.
Drawing-No.
ASS 3560 CO
rev05
Replace
SHEET

ASSMANN
WSW components
A company of BCS

A-IES-DIP-C