



AMP | AMP Superseal 1.5mm Series

TE Internal #: 282465-1

Tab, Mating Tab Width 1.5 mm [.059 in], Tab Thickness .8 mm [.031 in], 15 – 13 AWG Wire Size, AMP Superseal 1.5mm Series, Automotive Terminals

[View on TE.com >](#)

Terminals & Splices > Automotive Terminals > AMP SUPERSEAL 1.5MM, RECEPTACLE AND TAB

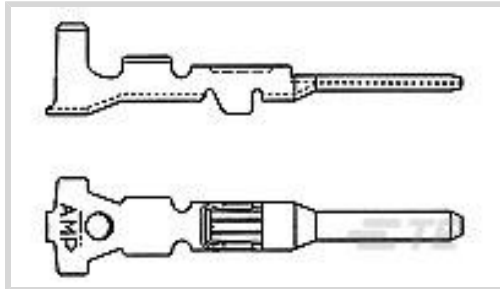

Terminal Type: **Tab**

Mating Tab Width: **1.5 mm [.059 in]**

Mating Tab Thickness: **.8 mm [.031 in]**

Terminal Transmits: **0 – 24 A (Low Power)**

Wire Size: **15 – 13 AWG**

[All AMP SUPERSEAL 1.5MM, RECEPTACLE AND TAB \(15\)](#)

## Features

### Operation/Application

Compatible With Wire Base Material	Copper
------------------------------------	--------

### Packaging Features

Packaging Method	Reel
Packaging Quantity	4000

### Usage Conditions

Insulation Option	Uninsulated
Operating Temperature (Max)	125 °C[257 °F]
Operating Temperature Range	-40 – 125 °C[-40 – 257 °F]

### Termination Features

Termination Method to Wire & Cable	Crimp
Product Terminates To	Wire

### Dimensions

Compatible Insulation Diameter Range	2.2 – 2.4 mm
Wire Size	1.5 – 2.5 mm <sup>2</sup>
Wire Size Search	2.5 mm <sup>2</sup> , 2 mm <sup>2</sup> , 1.5 mm <sup>2</sup>
Tab Length	22.7 mm[.893 in]



### Contact Features

Typical Current Rating	14 A
Crimp Type	F-Crimp
Contact Size	1.5mm
Contact Fabrication	Stamped & Formed
Wire Contact Termination Area Plating Material	Tin
Terminal Type	Tab
Mating Tab Width	1.5 mm [.059 in]
Mating Tab Thickness	.8 mm [.031 in]
Interface Plating	Tin (Sn)

### Product Type Features

Sealable	Yes
Primary Locking Feature	Clean Body

### Body Features

Terminal Seal Type	Single Wire Seal (SWS)
--------------------	------------------------

### Other

Terminal Transmits	0 – 24 A (Low Power)
EU RoHS Compliance	Compliant
EU ELV Compliance	Compliant

### Product Compliance

[For compliance documentation, visit the product page on TE.com>](#)

EU RoHS Directive 2011/65/EU	Compliant
EU ELV Directive 2000/53/EC	Compliant
China RoHS 2 Directive MIIT Order No 32, 2016	No Restricted Materials Above Threshold
EU REACH Regulation (EC) No. 1907/2006	Current ECHA Candidate List: JUNE 2024 (241) Candidate List Declared Against: JUNE 2024 (241) Does not contain REACH SVHC
Halogen Content	Low Halogen - Br, Cl, F, I < 900 ppm per homogenous material. Also BFR/CFR/PVC Free
Solder Process Capability	Not applicable for solder process capability

## Product Compliance Disclaimer

This information is provided based on reasonable inquiry of our suppliers and represents our current actual knowledge based on the information they provided. This information is subject to change. The part numbers that TE has identified as EU RoHS compliant have a maximum concentration of 0.1% by weight in homogenous materials for lead, hexavalent chromium, mercury, PBB, PBDE, DBP, BBP, DEHP, DIBP, and 0.01% for cadmium, or qualify for an exemption to these limits as defined in the Annexes of Directive 2011/65/EU (RoHS2). Finished electrical and electronic equipment products will be CE marked as required by Directive 2011/65/EU. Components may not be CE marked. Additionally, the part numbers that TE has identified as EU ELV compliant have a maximum concentration of 0.1% by weight in homogenous materials for lead, hexavalent chromium, and mercury, and 0.01% for cadmium, or qualify for an exemption to these limits as defined in the Annexes of Directive 2000/53/EC (ELV). Regarding the REACH Regulation, the information TE provides on SVHC in articles for this part number is based on the latest European Chemicals Agency (ECHA) 'Guidance on requirements for substances in articles' posted at this URL: <https://echa.europa.eu/guidance-documents/guidance-on-reach>

## Compatible Parts

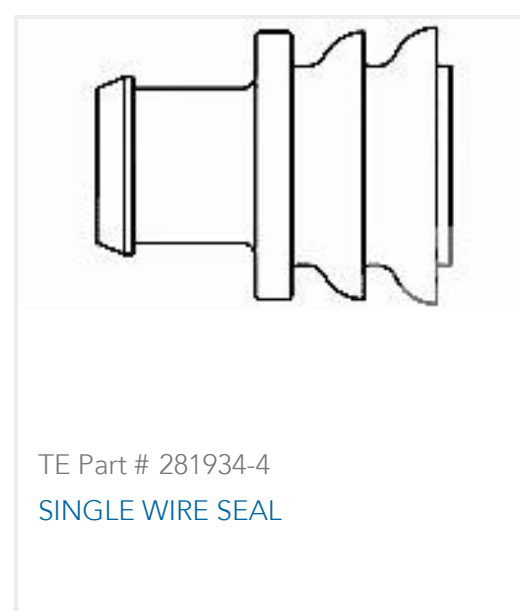
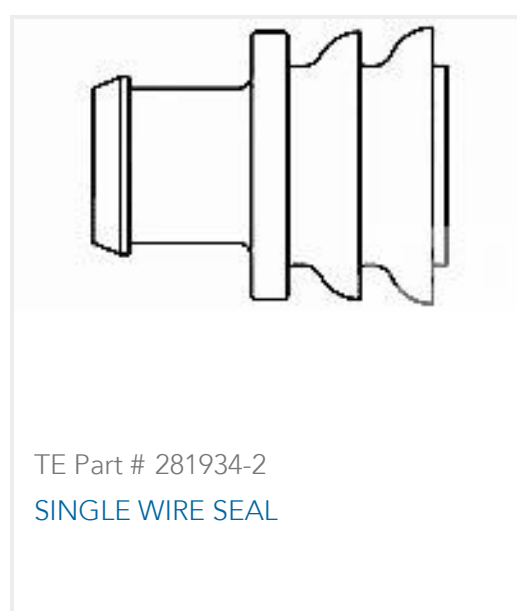
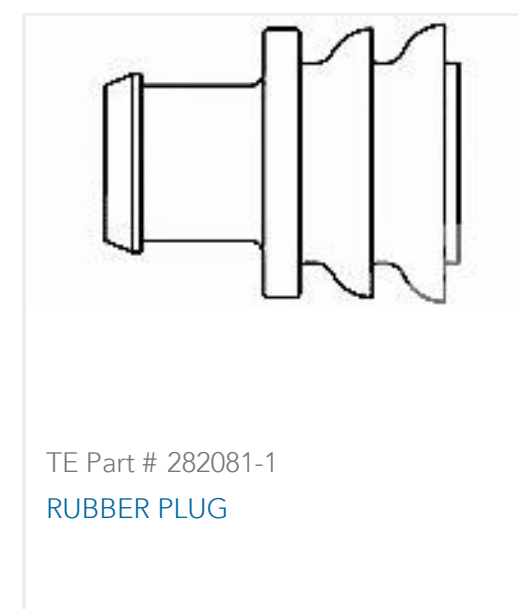
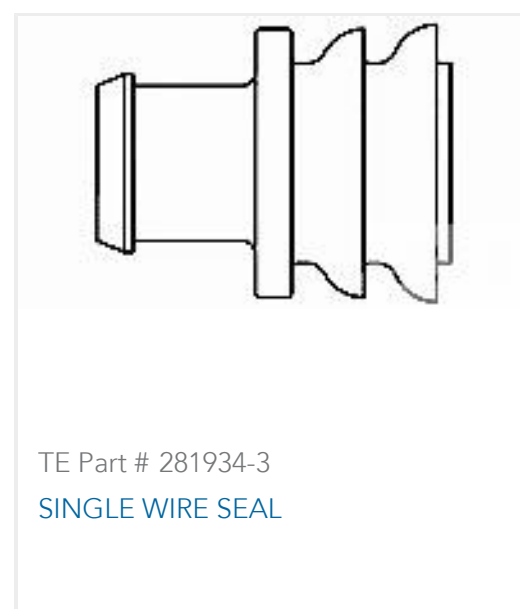

## Also in the Series | AMP Superseal 1.5mm Series

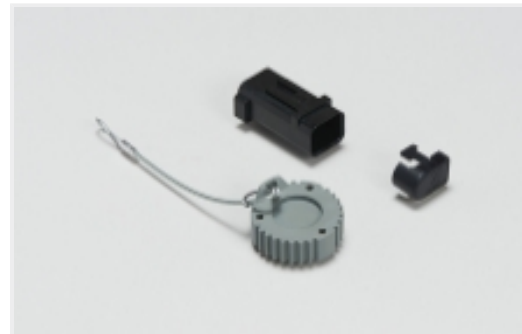

Automotive Connector Caps & Covers (1)

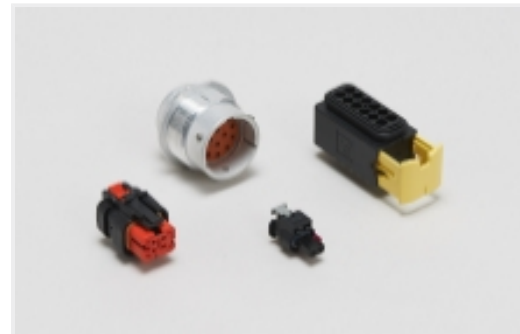

Automotive Housings(24)

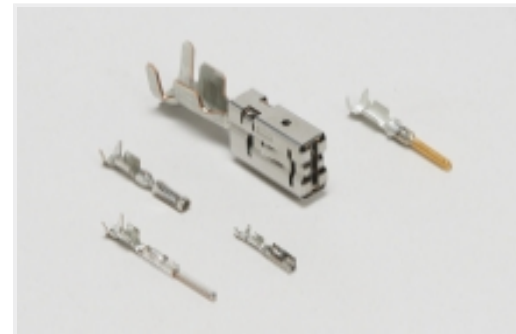

Automotive Terminals(16)



Connector Seals & Cavity Plugs(6)

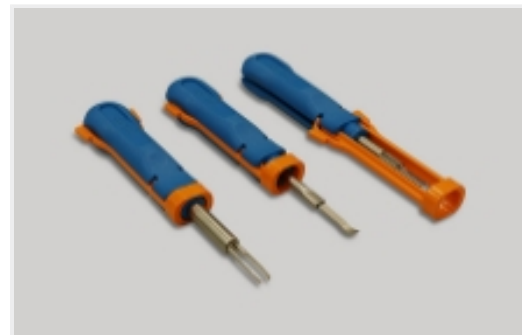

Insertion & Extraction Tools(3)

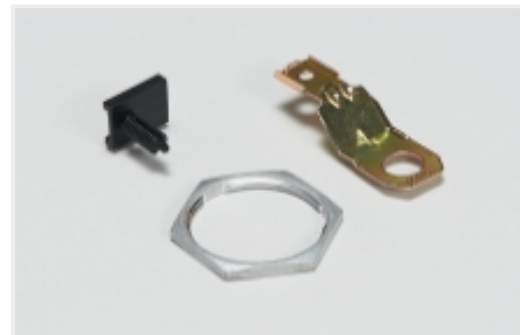

Other Automotive Connector Accessories(1)

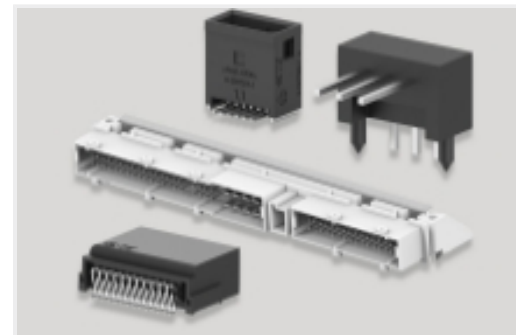

PCB Headers & Receptacles(1)

## Customers Also Bought



TE Part #282105-1  
AMP SUPERSEAL 1.5MM,  
CONNECTOR HOUSING

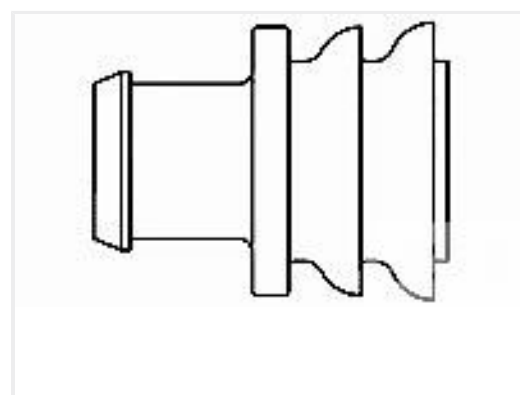

TE Part #281934-2  
SINGLE WIRE SEAL



TE Part #282404-1  
AMP SUPERSEAL 1.5MM,  
RECEPTACLE AND TAB



TE Part #172890-4  
4P 2MM MINI AMP-IN HDR HSG



TE Part #1544225-3  
PC 3V 6,35 MM NG1

## Documents

### Product Drawings

MINI MIC TAB CONTACT >1,5-

English

### CAD Files

Customer View Model

ENG\_CVM\_CVM\_282465-1\_A.2d\_dxf.zip



English

[3D PDF](#)

3D

Customer View Model

[ENG\\_CVM\\_CVM\\_282465-1\\_A.3d\\_igs.zip](#)

English

Customer View Model

[ENG\\_CVM\\_CVM\\_282465-1\\_A.3d\\_stp.zip](#)

English

By downloading the CAD file I accept and agree to the [Terms and Conditions](#) of use.

---

### Datasheets & Catalog Pages

[AMP SUPERSEAL 1.5mm Connector System](#)

English

[ICT Terminals and Connectors Catalogue](#)

English

---

### Product Specifications

[Application Specification](#)

English