

This document is the property of Amphenol Corporation and is delivered on the express condition that it is not to be disclosed, reproduced or used, in whole or in part, for manufacture or sale by anyone other than Amphenol Corporation without its prior consent, & that no right is granted to disclose or to use any information in this document.

CUSTOMER DRAWING

REVISIONS

SYM	ECN	DESCRIPTION	DATE	APPROVED
1	20XXXXXX	NEW RELEASE	2020/01/09	Tom.Tang
2	HKXXXX	Update	2020/12/25	Tom.Tang
3	HKXXXX	Add welding spot	2023/03/29	Tom.Tang

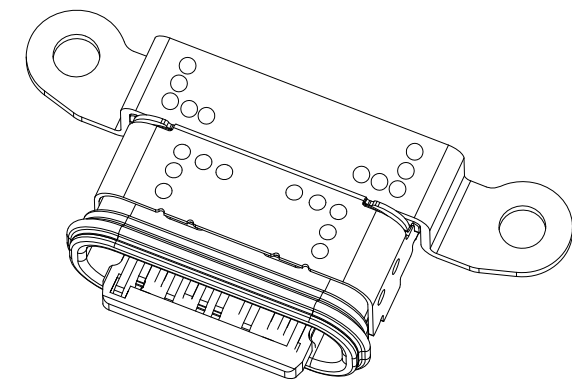
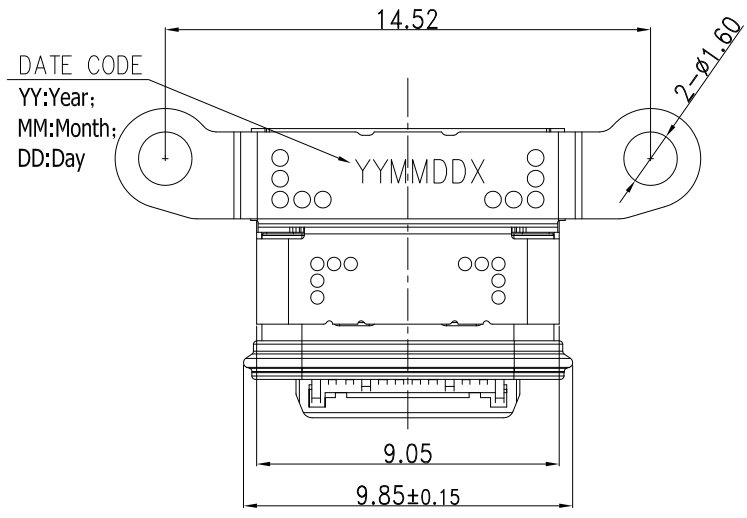

Pin No	Signal Name	Mating Sequence	Pin No	Signal Name	Mating Sequence
A1	GND	First	B12	GND	First
A2	TX1+	Second	B11	RX1+	Second
A3	TX1-	Second	B10	RX1-	Second
A4	Vbus	First	B9	Vbus	First
A5	CC1	Second	B8	SBU2	Second
A6	D+	Second	B7	D-	Second
A7	D-	Second	B6	D+	Second
A8	SBU1	Second	B5	CC2	Second
A9	Vbus	First	B4	Vbus	First
A10	RX2-	Second	B3	TX2-	Second
A11	RX2+	Second	B2	TX2+	Second
A12	GND	First	B1	GND	First
SHELL	GND		SHELL	GND	

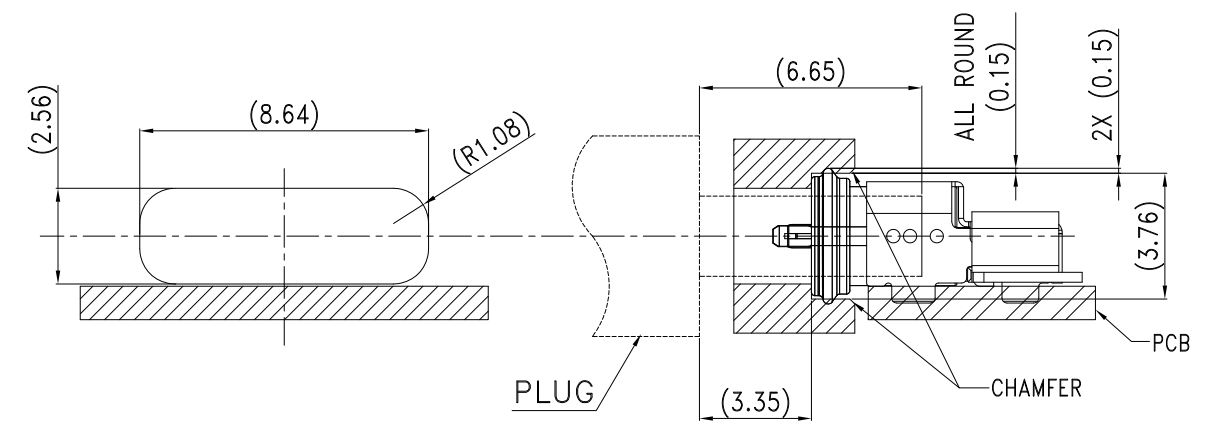
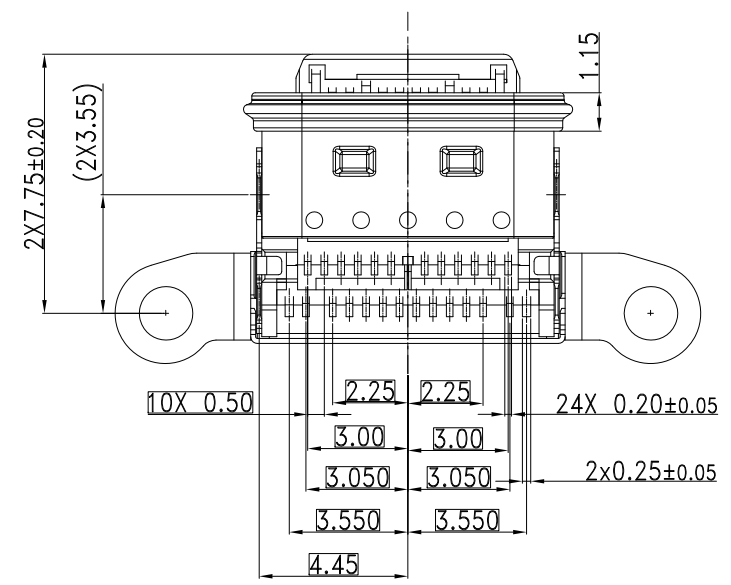
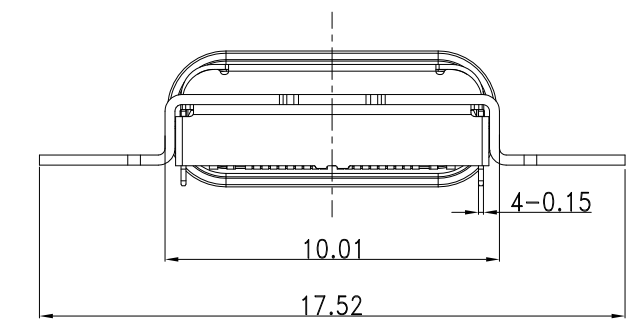
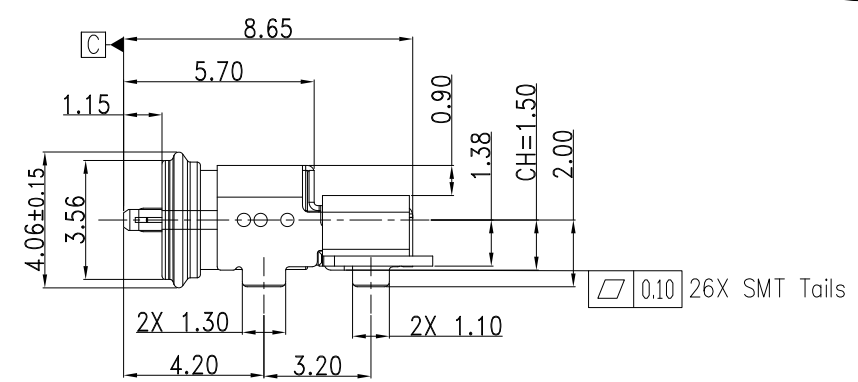
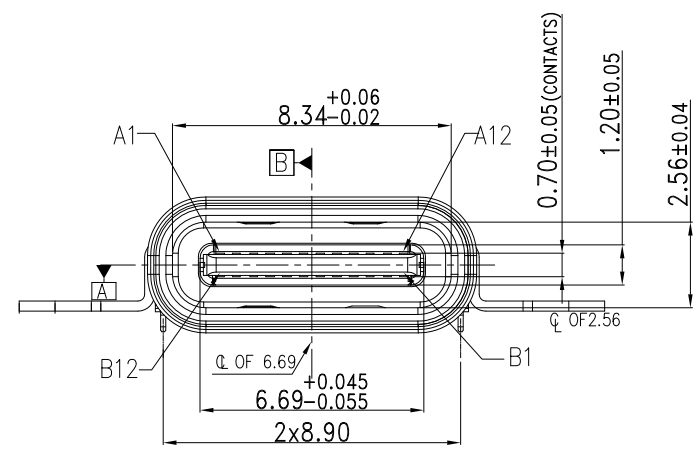

REF. PANEL DESIGN

UNLESS OTHERWISE SPECIFIED TOLERANCES U.S. METRIC .X +/- 0.50 .XX +/- 0.25 .XXX +/- 0.10 FRACTIONS +/- ANGLES +/- 3° FOR MATERIALS AND FINISHES SEE NOTES REMOVE SHARP EDGES DIMENSIONS U.S. INCHES (METRIC) (MM)	APPROVAL DRAWN Alec.II CHECKED Michael.qin CHECKED	DATE 03/29/23 03/29/23	Amphenol Amphenol East Asia Limited TITLE USB 3.1 GEN1, Type C socket connector, R/A_top mount, Double SMT type, CH=1.50mm, Waterproof IPX8 SIZE DRAWING NO. REV. A3 C 12401879 3 SCALE NONE SHEET 1 OF 2
	DRAWING FILE : S:\PE Master \PLM		
	ANGLE OF PROJECTION 		
	APPROVAL DATE		

This document is the property of Amphenol Corporation and is delivered on the express condition that it is not to be disclosed, reproduced or used, in whole or in part, for manufacture or sale by anyone other than Amphenol Corporation without its prior consent, & that no right is granted to disclose or to use any information in this document.

CUSTOMER DRAWING

REVISIONS				
SYM	ECN	DESCRIPTION	DATE	APPROVED
SEE PAGE1				

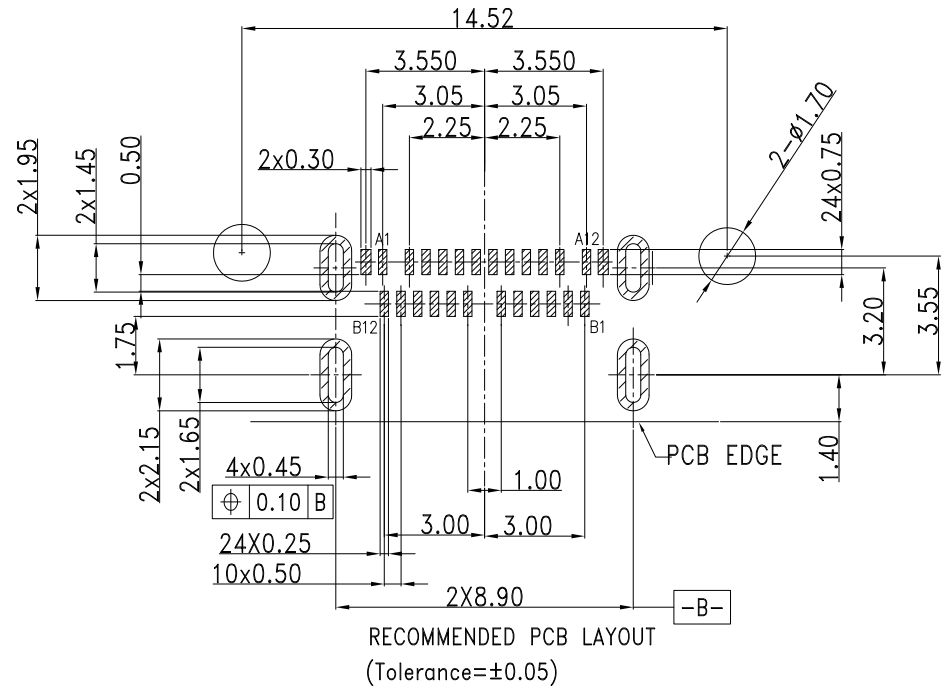
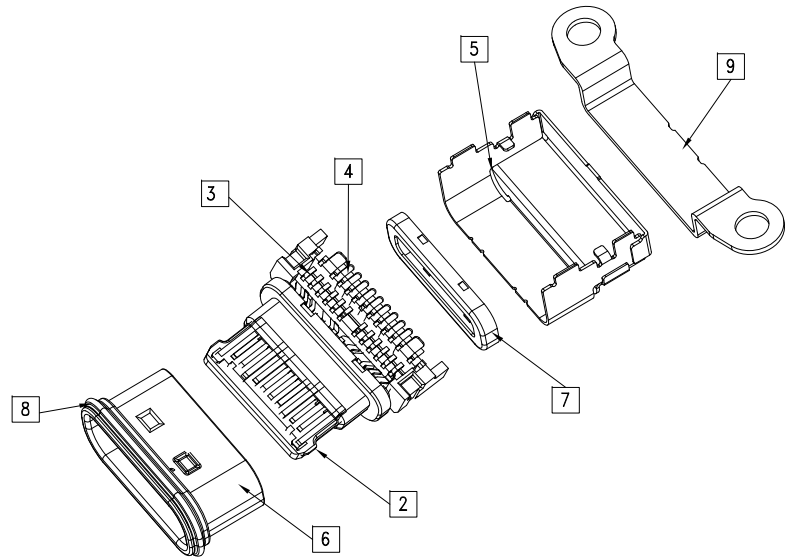

NOTES/注释:

- MATERIAL/材料: SEE TABLE/见下表
- GENERAL SPECIFICATION/通用特性:
 - COPLANARITY /共面度: 0.10 Max.
 - CURRENT RATING: 5A / 额定电流: 5安培
 - CONTACT RESISTANCE: 40mΩ MAX (INITIAL).
INSULATION RESISTANCE: 100MΩ Min
接触电阻: 40毫欧最大(初始值) / 绝缘电阻: 100MΩ Min
 - DIELECTRIC WITHSTANDING VOLTAGE: 100 VAC
耐电压: 100伏交流
 - MECHANICAL CHARACTERISTICS:
INSERTION FORCE: 5~20N EXTRACTION FORCE: 8~20N
AFTER DURABILITY EXTRACTION FORCE: 6~20N
力学特性: 初始插入力: 5~20N 拔出力: 8~20N
耐久后拔出力: 6~20N
 - DURABILITY: 10000 CYCLES / 耐久性: 10000次
 - PACKAGING TYPE: CARRIER TAPE./ 包装类型: 载带包装
- WATERPROOF CLASS IPX8/防水等级 IPX8
- DIMENSIONING SHALL BE INTERPRETED PER ASME Y14.5M 1994.
尺寸标注基于ASME Y14.5M 1994标准规范
- MATERIAL SHOULD BE FULFILLED AMPHENOL SPEC.# S-SN-002, FOR HALOGEN FREE PRODUCTS, ALSO NEED TO MEET S-SN-004.
产品材料环保标准为Amphenol SSN#002,如果是无卤产品需满足标准SSN#004
- ORDER P/N SYSTEM/产品料号编码系统 : 12401879XX12A

Plating Spec:

21: Mating Area: Au 30u" Min
Solder Area: Gold flash
50u"Min Nickel Under Plating Over All

A:HF
Package Spec.
2:Reel
Date Code Description
0:Without D/C
1:With D/C

20pcs empty 800pcs products 20pcs Empty

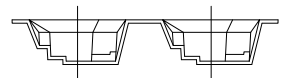
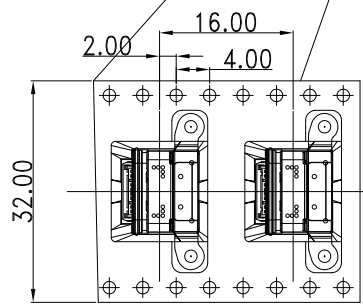

customer unwinding direction

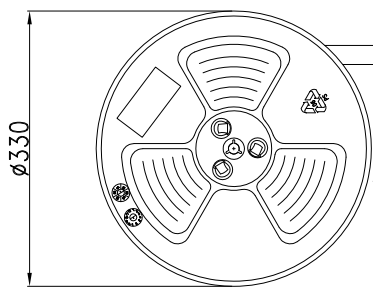

PACK DIRECTION

Packing:
1. 800 Pcs/Reel.
2. 8 Reels/Carton.

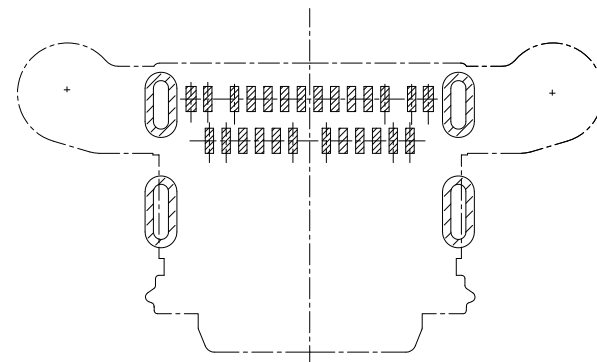

Keep out zone
(Connector mount layer)



ITEM	DESCRIPTION	Q'TY	MATERIAL	FINISH
9	OUTER SHELL	1	STAINLESS STEEL	CLEAN
8	LIM	1	CHN-IMS-50-A/B	BLACK
7	SMALL SHELL	1	STAINLESS STEEL	CLEAN
6	MAIN SHELL	1	STAINLESS STEEL	CLEAN
5	SUB-SHELL	1	STAINLESS STEEL	Solser Nickel: 50U" MIN
4	TOP TERMINAL	1	COPPER ALLOY	SEE NOTES
3	BOTTOM TERMINAL	1	COPPER ALLOY	SEE NOTES
2	MID PLATE	1	STAINLESS STEEL	NICKEL: 50U" MIN
1	MAIN HOUSING	1	High Temperature plastic	BLACK

BILL OF MATERIAL			
UNLESS OTHERWISE SPECIFIED TOLERANCES		APPROVAL	DATE
U.S. METRIC		DRAWN Alec.ii	03/29/23
.X +/- 0.50		CHECKED Michael.qin	03/29/23
.XX +/- 0.25		CHECKED	
.XXX +/- 0.10			
FRACTIONS +/-			
ANGLES +/- 3'			
FOR MATERIALS AND FINISHES SEE NOTES		DRAWING FILE :	
REMOVE SHARP EDGES		S:\PE Master \PLM	
DIMENSIONS		ANGLE OF PROJECTION	
U.S. INCHES	(METRIC) (MM)		
TITLE		Amphenol	
Amphenol East Asia Limited		USB 3.1 GEN1, Type C socket connector, R/A ,top mount, Double SMT type, CH=1.50mm, Waterproof IPX8	
SIZE	DRAWING NO.	REV.	
A3	C 12401879	3	
SCALE	NONE	SHEET 2 OF 2	