

REVISIONS				
REV	DESCRIPTION	DATE	BY	APPD
W	REVISED PER ECR-25-253035	11NOV2025	CKN	JP

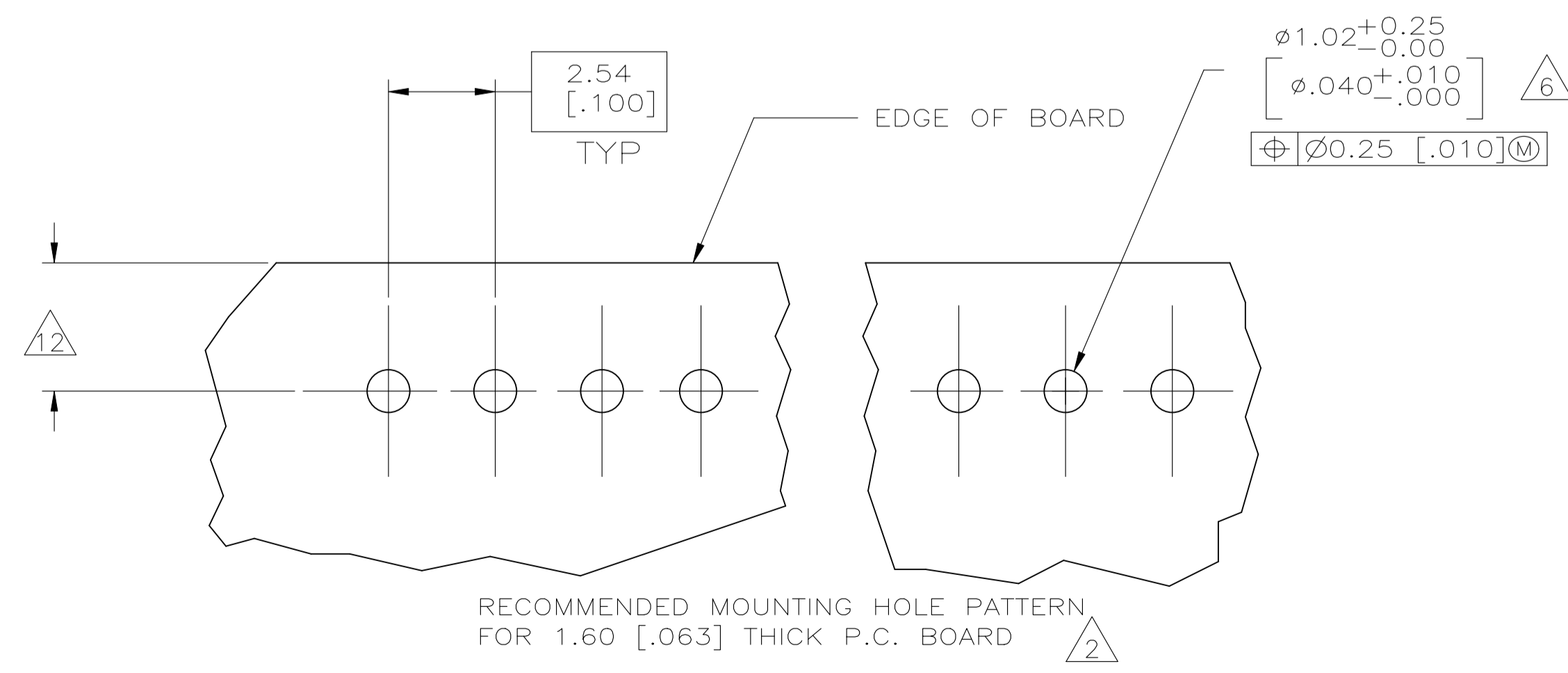
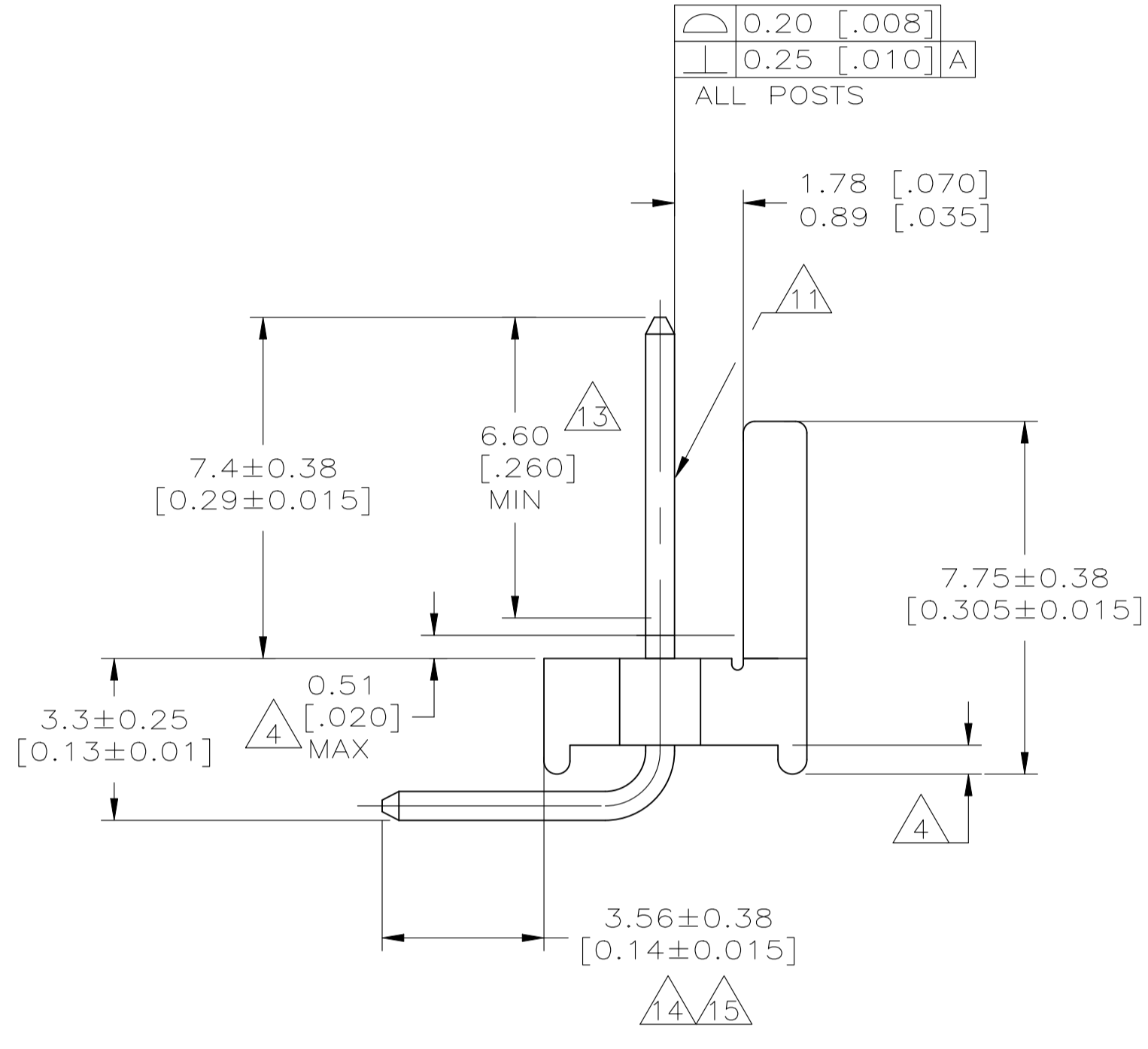
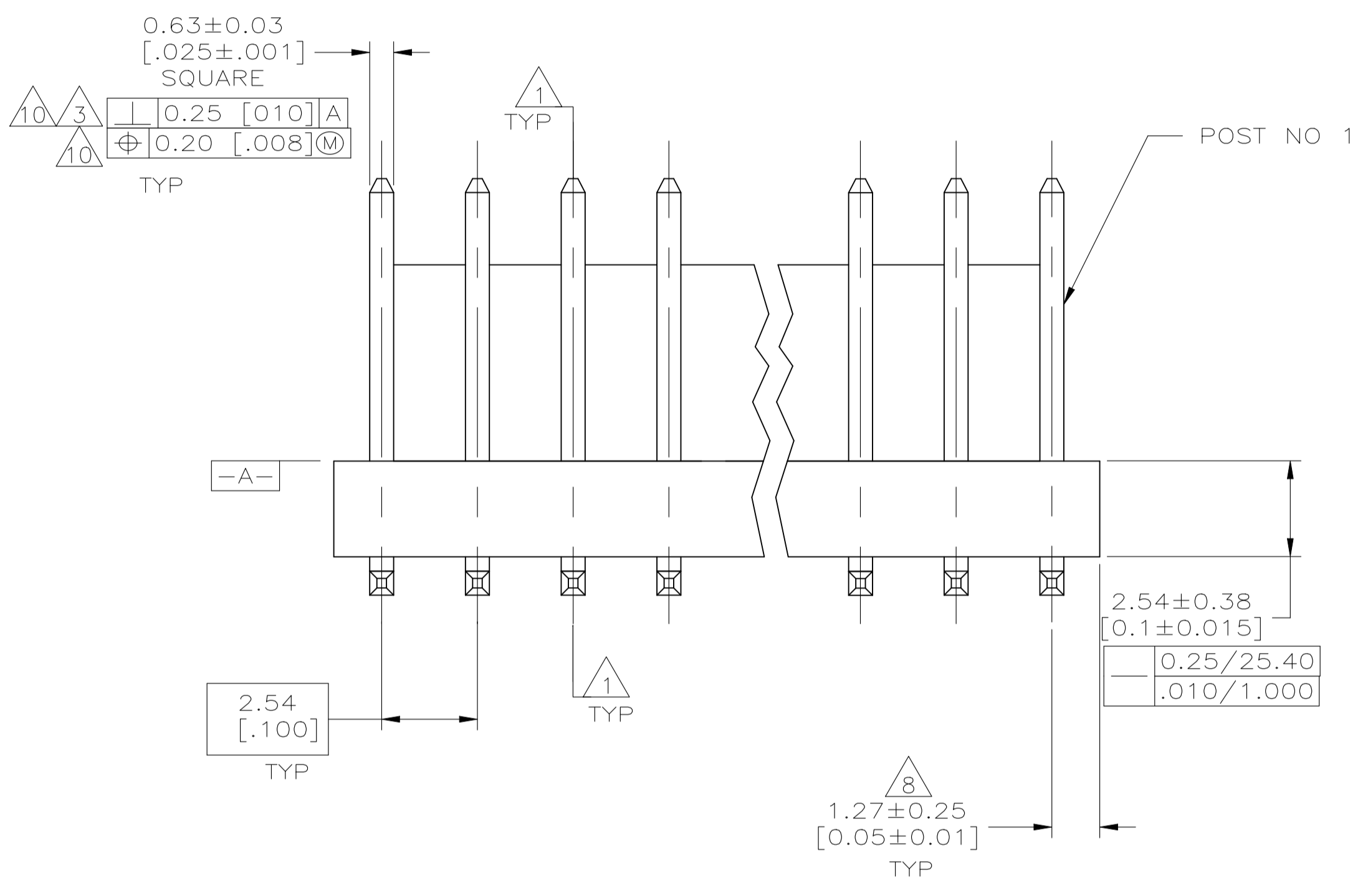
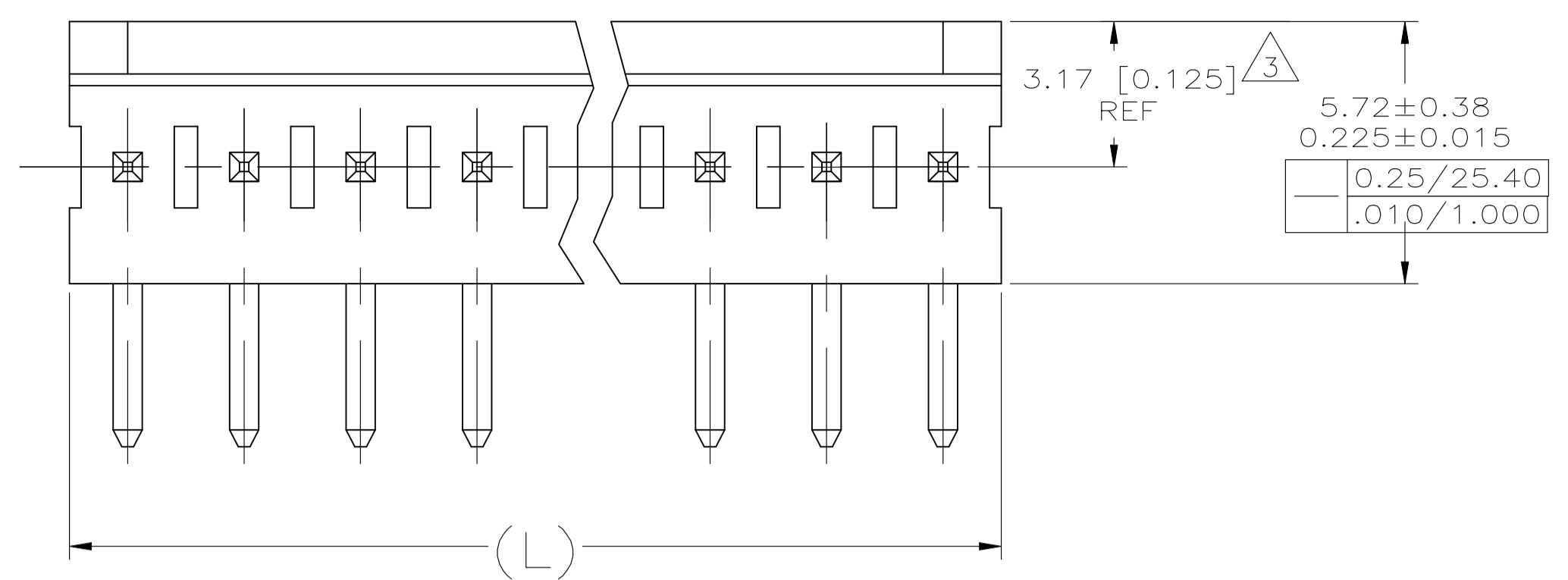

- 1 POST TO WITHSTAND 13 NEWTONS (3 LBS) MINIMUM AXIAL FORCE IN BOTH DIRECTIONS SHOWN WITHOUT DISLODGING.
- 2 TOLERANCES APPLY TO SOLDER SIDE OF BOARD.
- 3 MEASURED AT **-A-**
- 4 PLASTIC FLASH PERMITTED IN THIS AREA.
- 5 PARTS COMPLY WITH AMP SOLDERABILITY SPEC. NO. 109-11-2.
- 6 ONE HOLE MAY BE UNDERSIZED 0.81-0.89 [.032-.035] DIA. FOR ASSEMBLY RETENTION DURING WAVE SOLDERING.
- 7 MATERIAL: HEADER-THERMOPLASTIC POLYESTER
94V-0 (NATURAL)
POST-COPPER ALLOY
FINISH-USE PLATING NOTES 13 & 14 FOR -2 THRU -18
AND NOTES 13 & 15 FOR -32 THRU -58
- 8 COORDINATE DIMENSION APPLIES FROM CENTER OF ACTUAL FEATURE.
- 9 PLASTIC BURRS CAUSED BY CUT-OFF TOOLING ARE PERMITTED WITHIN THE MAXIMUM TOLERANCE ENVELOPE.
- 10 POSTS TO BE MEASURED WHEN STRIP IS HELD FLAT.
- 11 POST MUST WITHSTAND TWO 90° BENDS AGAINST EXTRUSION WITHOUT BREAKING.
- 12 DIMENSION SHOULD BE 2.79-4.06 [.110-.160] MIN WHEN MATING WITH A MTA-100 CONNECTOR ASSEMBLY OR 2.79-3.05 [.110-.120] WHEN MATING WITH A CST-100 CONNECTOR ASSEMBLY.
- 13 PLATING: GOLD PLATE AREA, 0.00076 [.000030] GOLD OR 0.00008 [.000003] MIN GOLD FLASH OVER 0.00068 [.000027] PALLADIUM NICKEL ONLY IN FUNCTIONAL CONTACT AREA PER TE AND OTHER AREAS WITH OPTIMIZED THICKNESS CONNECTIVITY'S DISCRETION, ALL SIDES, OVER NICKEL UNDERPLATE, .00127 [.000050] MIN, ALL SIDES AND ENTIRE LENGTH OF POST.
- 14 PLATING: BRIGHT TIN/LEAD (93/7) PLATE AREA, 0.00381-0.00889 [.000150-.000350] THICK, ALL FOUR SIDES 3.56 [.140] MINIMUM.
- 15 PLATING: MATTE TIN PLATE AREA, 0.00381-0.00889 [.000150-.000350] THICK, ALL FOUR SIDES 3.56 [.140] MINIMUM.
- 16 OBSOLETE PARTS: OBSOLETE CIS STREAMLINING PER D.RENAUD/D.SINISI

LEAD FREE	DIM (L)		NO. OF POSN	ASSEMBLY
	mm	[INCHES]		
	45.72	[1.800]	18	4-641214-8
	43.18	[1.700]	17	4-641214-7
	40.64	[1.600]	16	4-641214-6
	38.10	[1.500]	15	4-641214-5
	35.56	[1.400]	14	4-641214-4
	33.02	[1.300]	13	4-641214-3
	30.48	[1.200]	12	4-641214-2
	27.94	[1.100]	11	4-641214-1
	25.40	[1.000]	10	4-641214-0
	22.86	[.900]	9	3-641214-9
	20.32	[.800]	8	3-641214-8
	17.78	[.700]	7	3-641214-7
	15.24	[.600]	6	3-641214-6
	12.70	[.500]	5	3-641214-5
	10.16	[.400]	4	3-641214-4
	7.62	[.300]	3	3-641214-3
	5.08	[.200]	2	3-641214-2
	DIM (L)		NO. OF POSN	ASSEMBLY

LEAD	DIM (L)		NO. OF POSN	ASSEMBLY
	mm	[INCHES]		
	45.72	[1.800]	18	1-641214-8
	43.18	[1.700]	17	1-641214-7
	40.64	[1.600]	16	1-641214-6
	38.10	[1.500]	15	1-641214-5
	35.56	[1.400]	14	1-641214-4
	33.02	[1.300]	13	1-641214-3
	30.48	[1.200]	12	1-641214-2
	27.94	[1.100]	11	1-641214-1
	25.40	[1.000]	10	1-641214-0
	22.86	[.900]	9	641214-9
	20.32	[.800]	8	641214-8
	17.78	[.700]	7	641214-7
	15.24	[.600]	6	641214-6
	12.70	[.500]	5	641214-5
	10.16	[.400]	4	641214-4
	7.62	[.300]	3	641214-3
	5.08	[.200]	2	641214-2
	DIM (L)		NO. OF POSN	ASSEMBLY

THIS DRAWING IS A CONTROLLED DOCUMENT.

DIMENSIONS: mm [INCHES]	TOLERANCES UNLESS OTHERWISE SPECIFIED:	DIN S. HOOVER 26-JAN-2005	CHK D. BOSSI 26-JAN-2005	APPROVED D. BOSSI 26-JAN-2005	NAME
0. PLC ±	1. PLC ±	2. PLC ±	3. PLC ±	4. PLC ±	ANGLES ±
					± 0.13 [.005]
MATERIAL	FINISH	WEIGHT	SIZE	CAGE CODE	DRAWING NO
			A1	00779	641214
CUSTOMER DRAWING		SCALE	SHEET	REV	
		8:1	1 of 1	W	

MTA-100 HEADER ASSEMBLY, POLARIZED, NOTCHED, .025 SQUARE RIGHT ANGLE POST, .000030 GOLD PLATED