

REVISIONS					
P	LTR	DESCRIPTION	DATE	DWN	APVD
E1		REVISED PER ECN-26-381559	24DEC2025	AP	SKN

NOTE:

1. MATERIAL:

HOUSING: PBT WITH 20% GF UL 94 V-0, BLACK COLOR
 CONTACTS: PHOSPHOR BRONZE.
 SHELL: STEEL.
 SCREW: BRASS.
 SCREW LOCK: BRASS.
 SCREW TORQUE: 5kgf-cm MAX.

2. FINISH:

CONTACTS: GOLD PLATED 0.375µm [15µ"] MIN OR GOLD FLASH OVER
 PALLADIUM NICKEL PLATE 0.375µm [15µ"] MIN ON CONTACT AREA.
 MATTE TIN ON SOLDER TAIL 2.54µm [100µ"],
 WITH ENTIRE CONTACT
 UNDERPLATED 1.27µm [50µ"] MIN. NICKEL.
 FRONT SHELL: 2.54µm [100µ"] MIN. NICKEL PLATED.
 REAR SHELL: 1.27µm [50µ"] MIN NICKEL UNDERPLATE.
 2.54µm [100µ"] MIN BRIGHT TIN PLATE
 SCREW LOCK: 1.27µm [50µ"] MIN. NICKEL PLATED.
 BOARDLOCK: 1.27µm [50µ"] MIN NICKEL UNDERPLATE.
 1.27µm [50µ"] MIN MATTE TIN PLATE

3. WAVE SOLDER CAPABLE TO 265°C PER TE TEST SPEC. 109-202, CONDITION B.

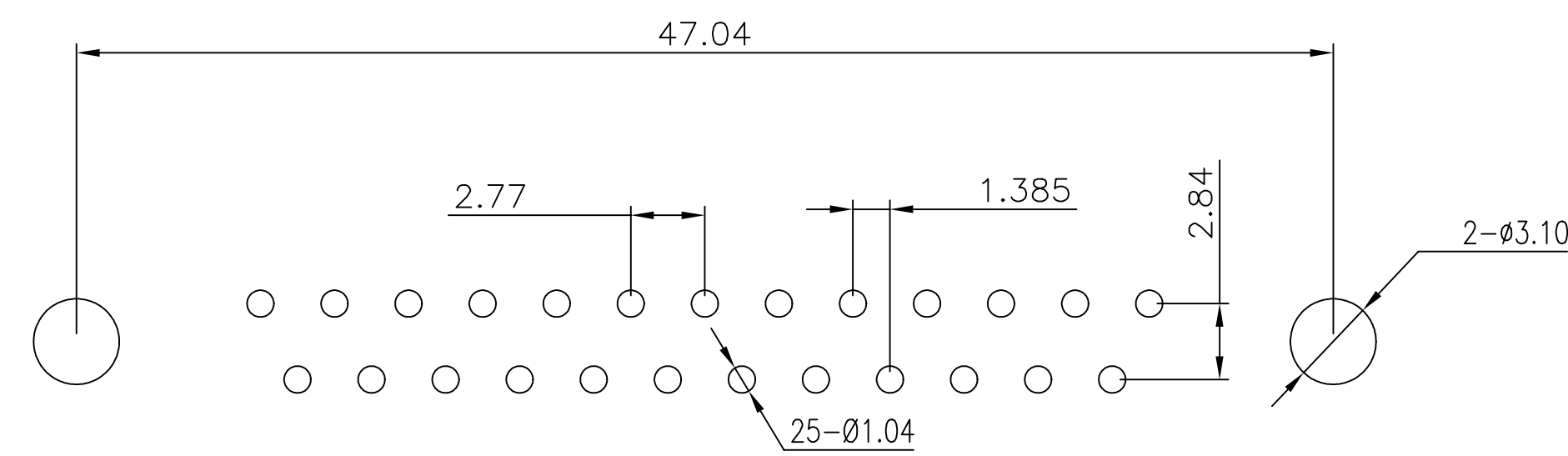
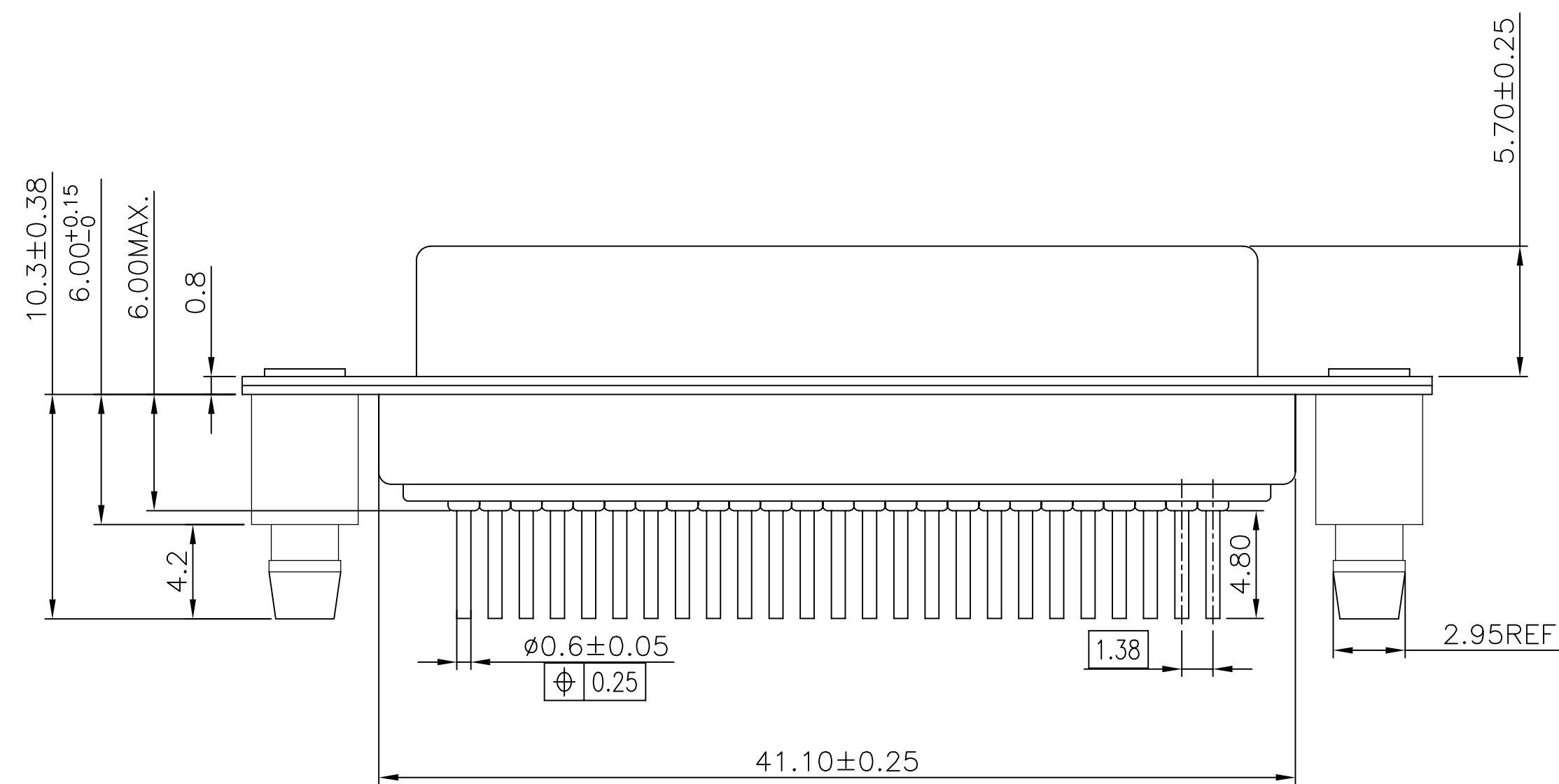
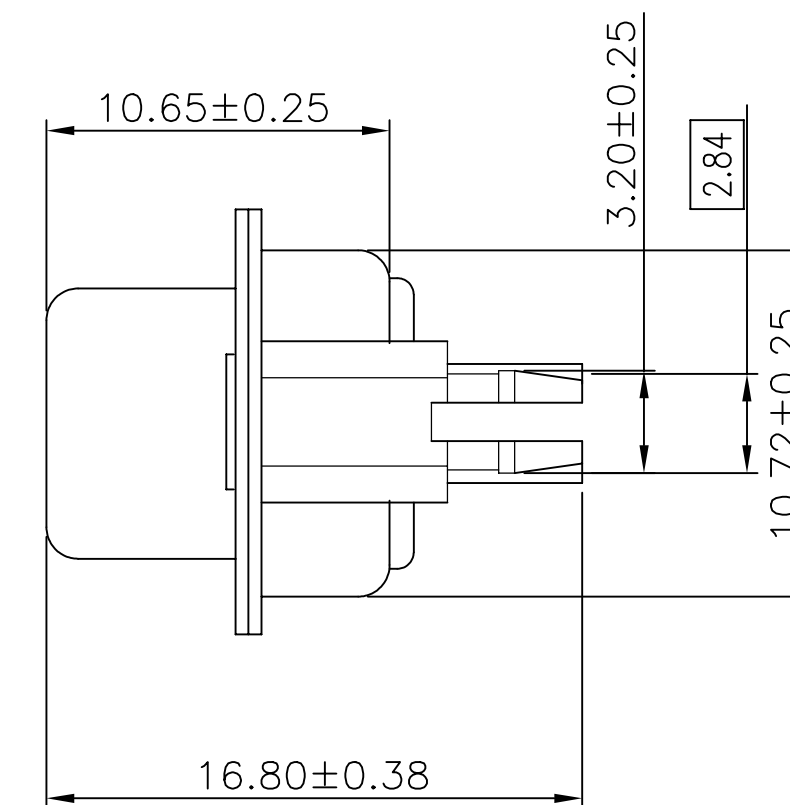
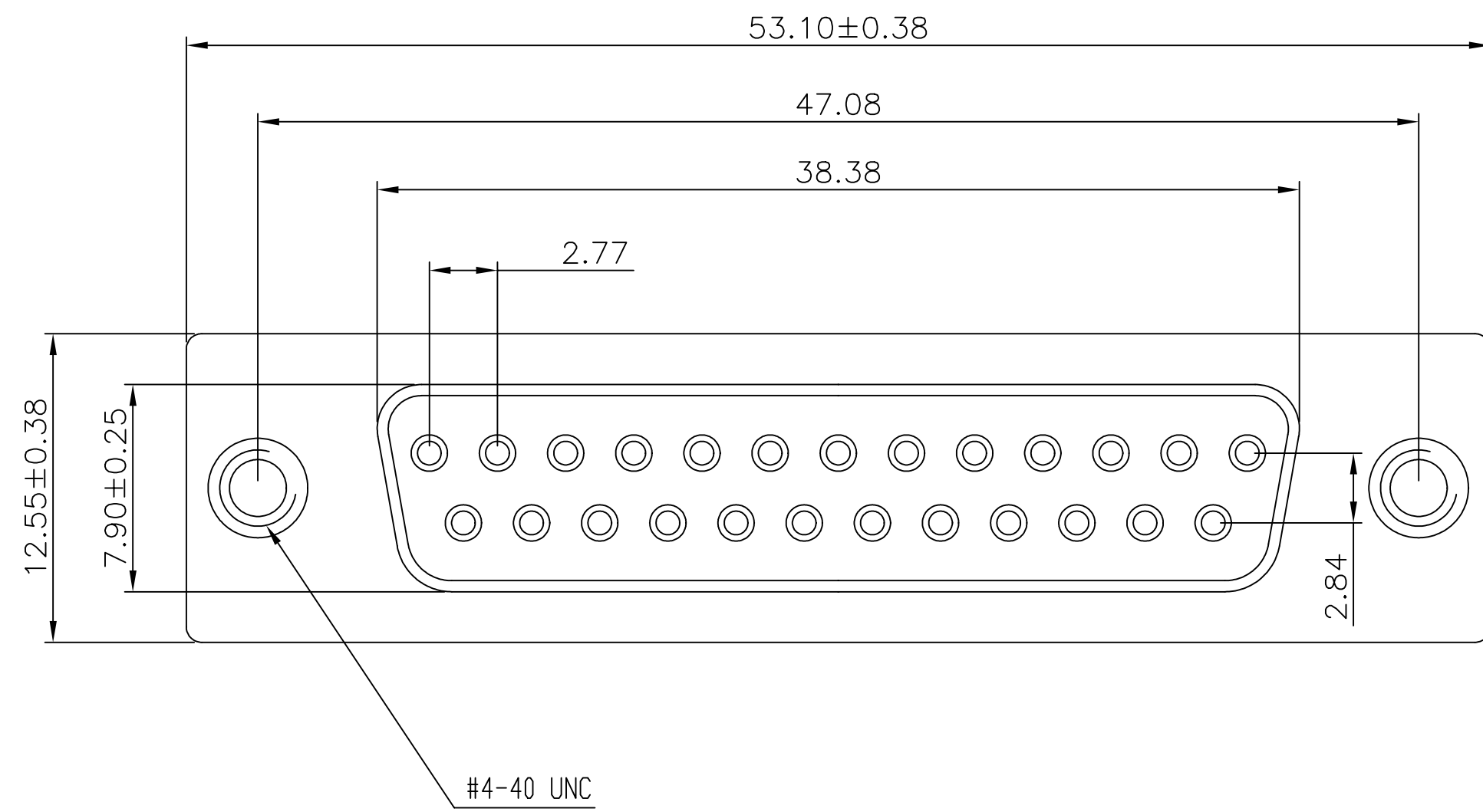

RECOMMENDED PCB LAYOUT

25w D skt W B/L & 4-40 inserts	2301841-1
DESCRIPTION	TE PART NO

THIS DRAWING IS A CONTROLLED DOCUMENT.		DWN AJITH PAI 07FEB2017	TE Connectivity Ltd.	
DIMENSIONS: mm		CHK DAN GORENC 07FEB2017	D-SUB VERTICAL 25P SKT CONNECTOR	
TOLERANCES UNLESS OTHERWISE SPECIFIED:		APVD - 07FEB2017	NAME	
0 PLC ± -	1 PLC ± 0.25	PRODUCT SPEC 108-130013	SIZE CAGE CODE DRAWING NO RESTRICTED TO	
2 PLC ± 0.15	3 PLC ± -	APPLICATION SPEC	A2 00779 C=2301841	-
4 PLC ± -	ANGLES ± 2°	WEIGHT 0	SCALE 3:1	SHEET 1 of 4
MATERIAL -	FINISH -	CUSTOMER DRAWING	REV E1	

REVISIONS					
P	LTR	DESCRIPTION	DATE	DWN	APVD
-	-	SEE SHEET 1	-	-	-

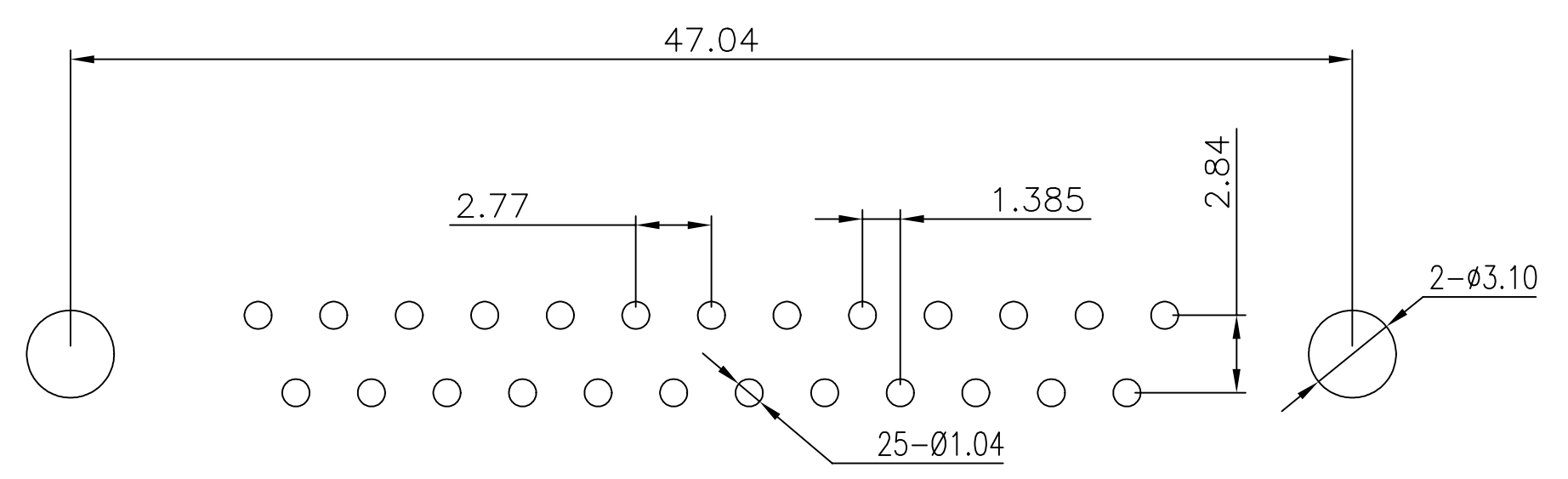
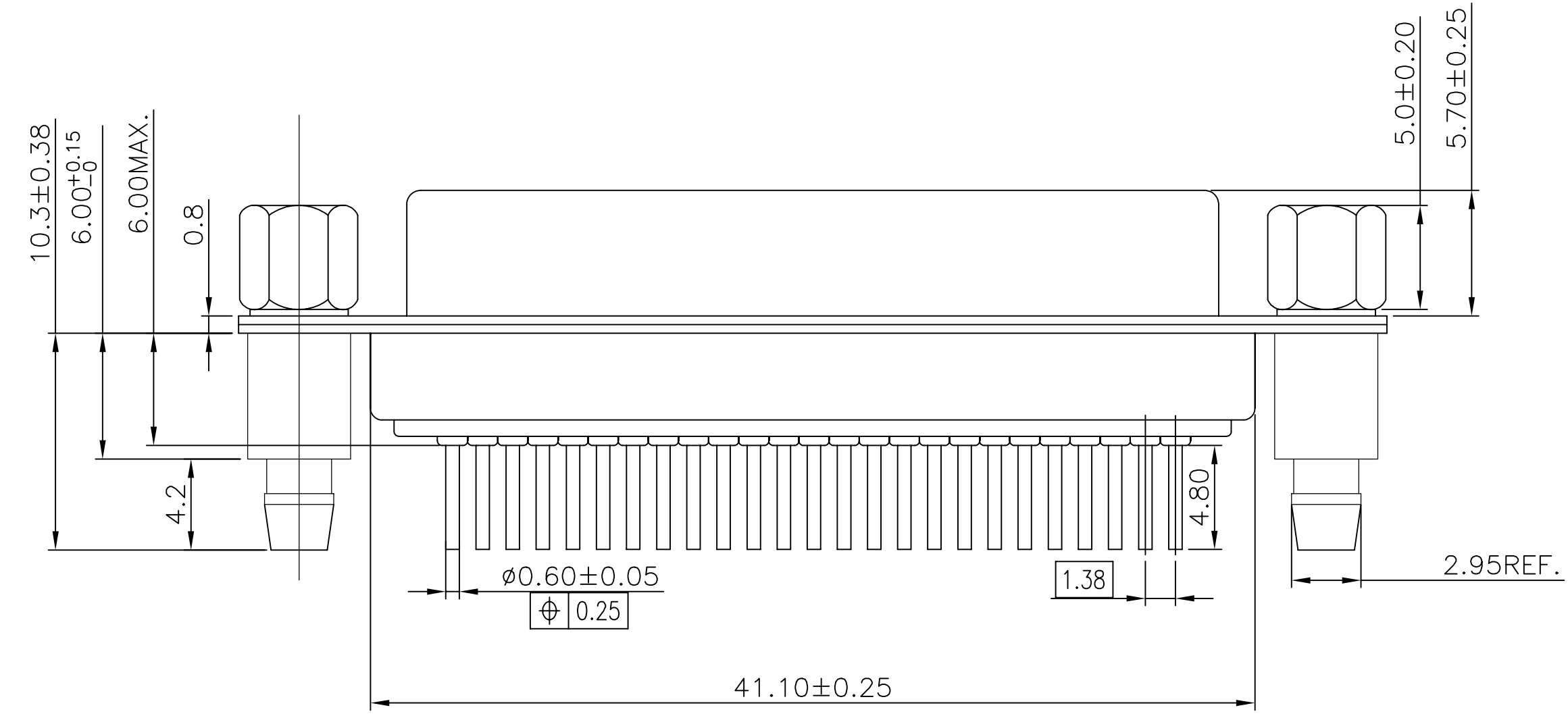
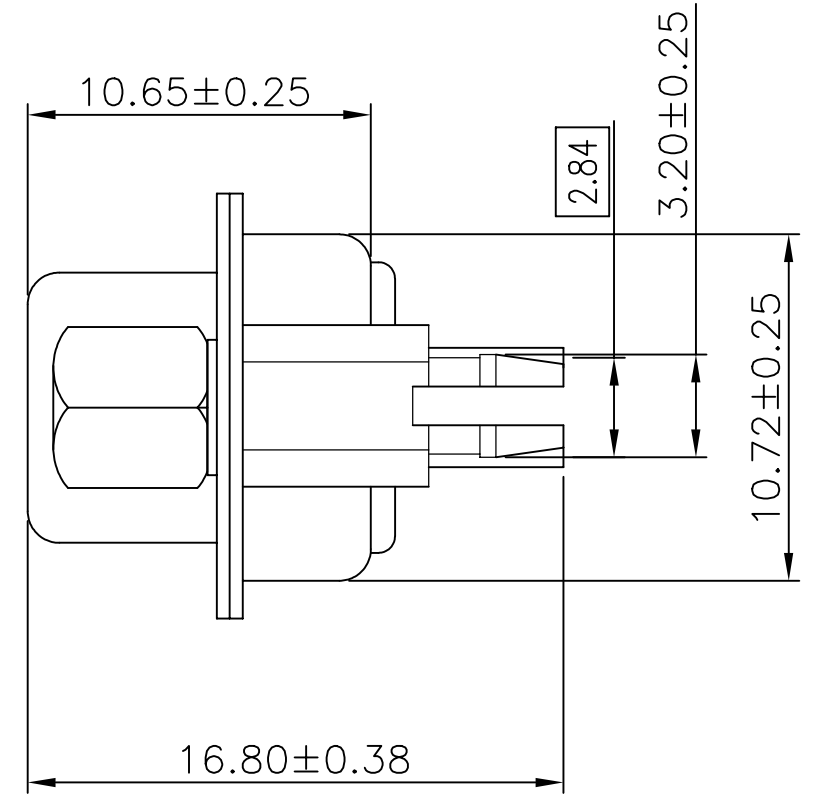
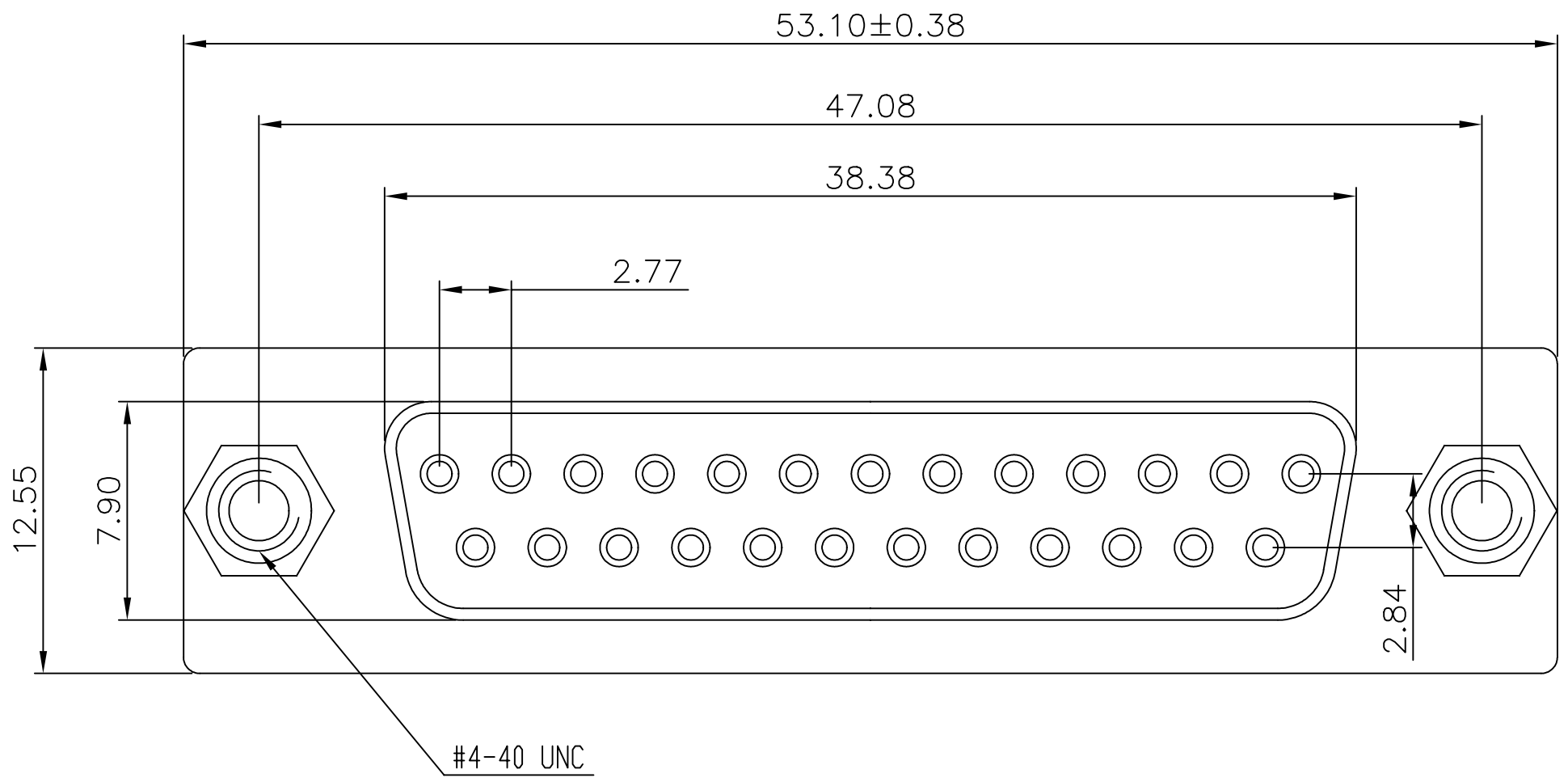

RECOMMENDED PCB LAYOUT

25w D skt W B/L & 4-40 s/lock	2301841-2
DESCRIPTION	TE PART NO

THIS DRAWING IS A CONTROLLED DOCUMENT.		DWN	AJITH PAI	07FEB2017	TE Connectivity Ltd.			
		CHK	DAN GORENC	07FEB2017				
		APVD	-	07FEB2017				
		PRODUCT SPEC	108-130013					
		APPLICATION SPEC	-		NAME	D-SUB VERTICAL 25P SKT CONNECTOR		
DIMENSIONS:		TOLERANCES UNLESS OTHERWISE SPECIFIED:		SIZE		CAGE CODE	DRAWING NO	RESTRICTED TO
mm		0 PLC ± -		A2		00779	C=2301841	-
		1 PLC ± 0.25		SCALE		3:1	SHEET	2 of 4
		2 PLC ± 0.15		CUSTOMER DRAWING			REV	E1
		3 PLC ± -		WEIGHT		0		
		4 PLC ± -		MATERIAL		-		
		ANGLES ± 2°		FINISH		-		

REVISIONS				
P	LTR	DESCRIPTION	DATE	APVD
-	-	SEE SHEET 1	-	-

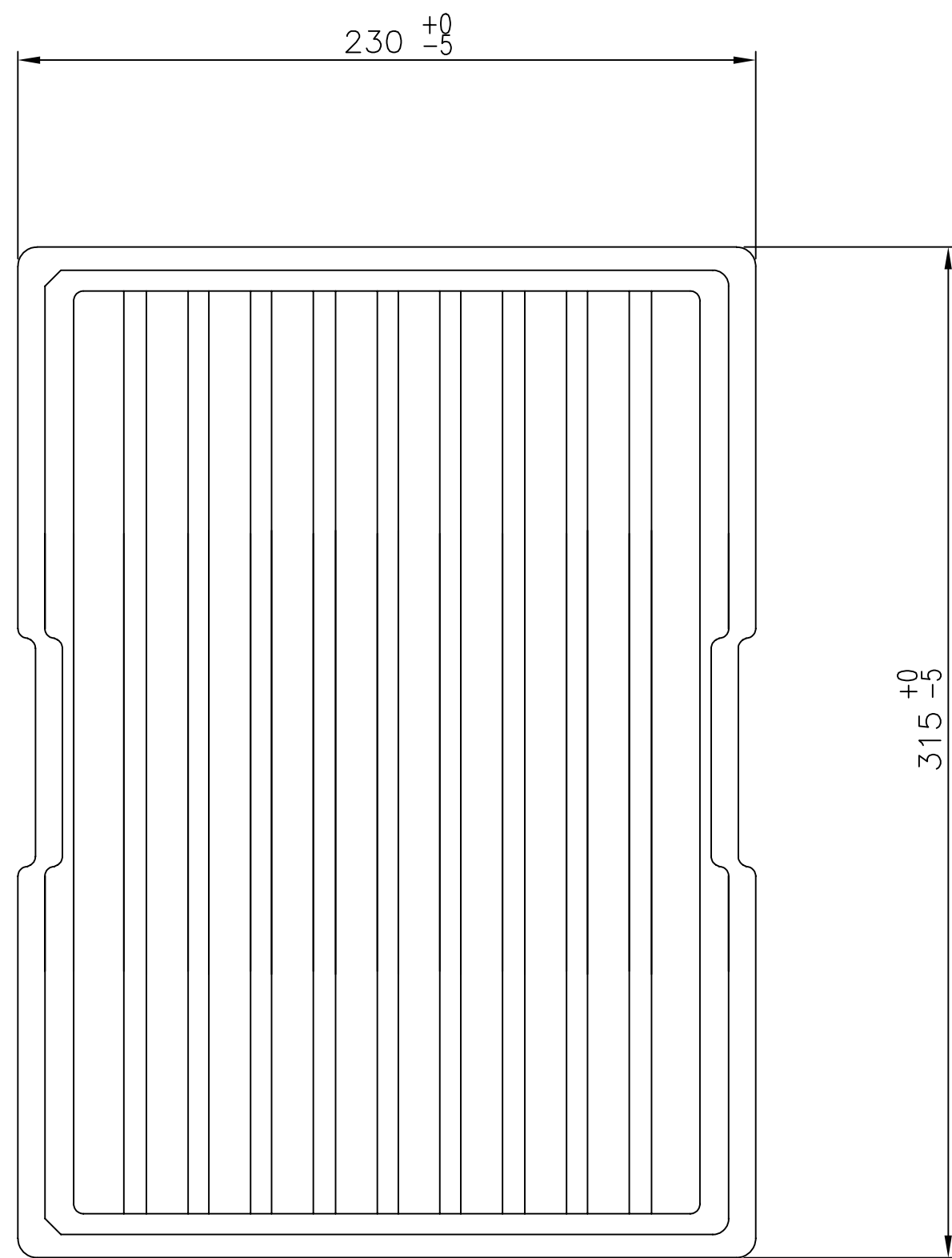
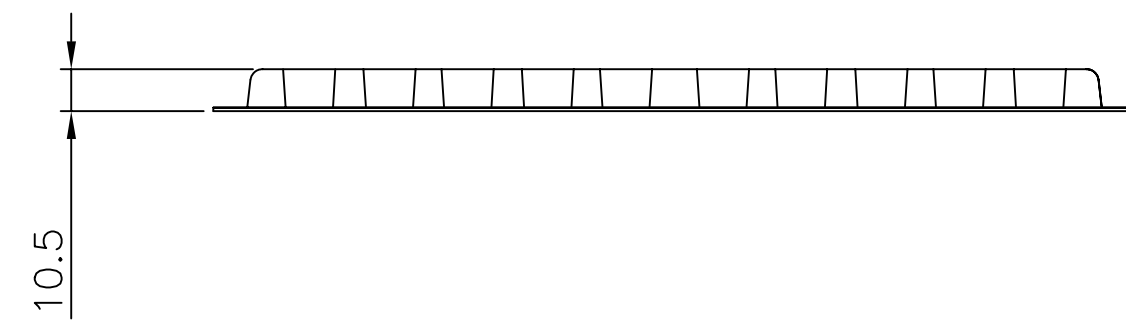

P-DBS13-D43300

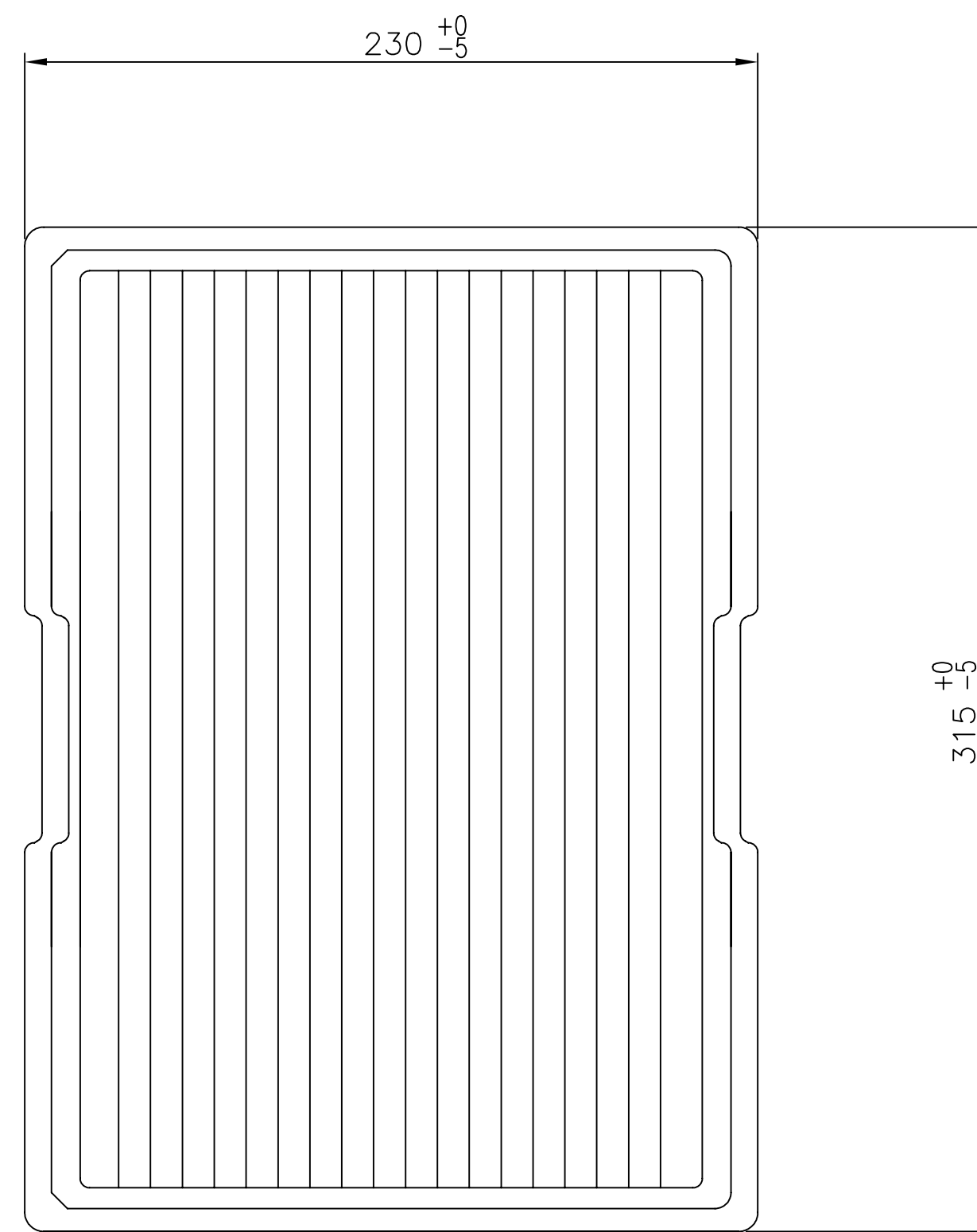
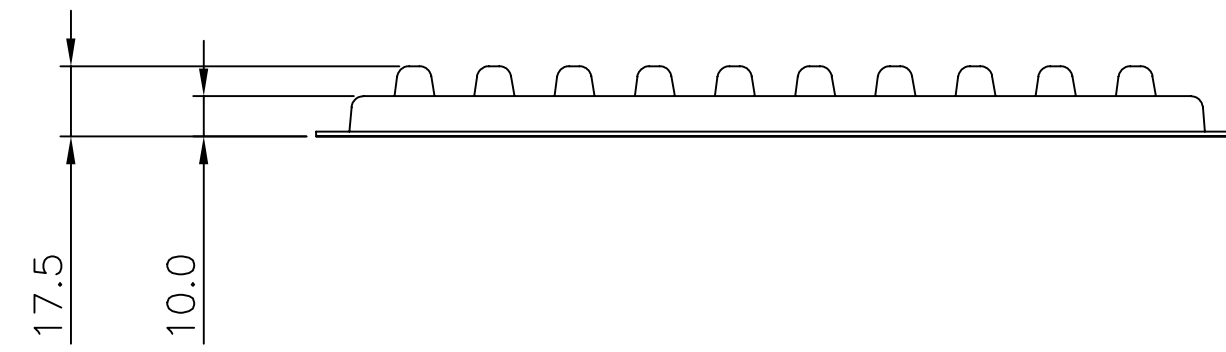

P-DBS13-U43300

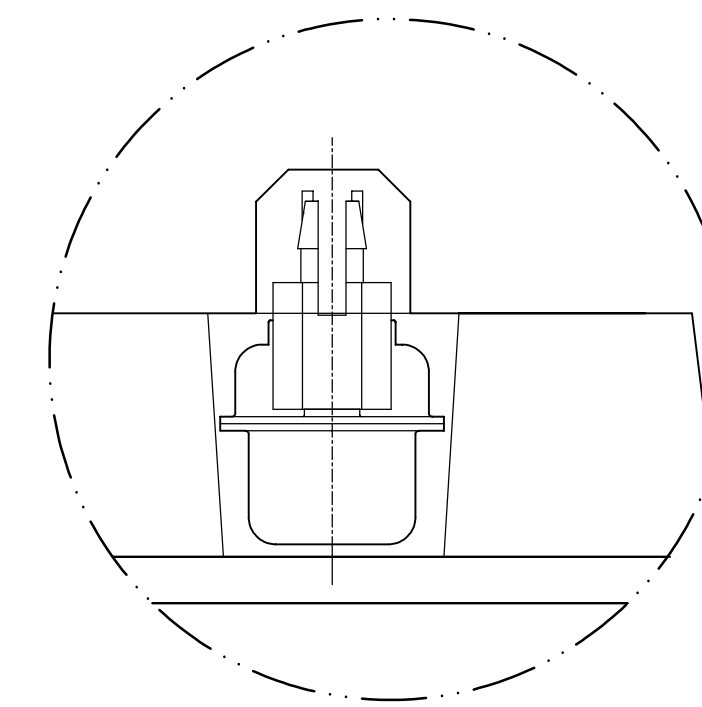

DETAIL A

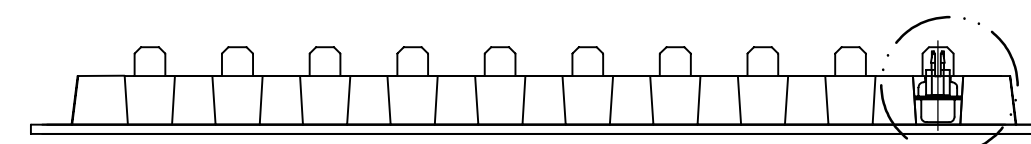

SEE DETAIL A

THIS DRAWING IS A CONTROLLED DOCUMENT.		DWN AJITH PAI 07FEB2017	TE Connectivity Ltd.	
		CHK DAN GORENC 07FEB2017		
		APVD - 07FEB2017	NAME	
DIMENSIONS: mm		PRODUCT SPEC 108-130013	D-SUB VERTICAL 25P SKT CONNECTOR	
TOLERANCES UNLESS OTHERWISE SPECIFIED:		APPLICATION SPEC	SIZE A2	CAGE CODE 00779
0 PLC ± -		WEIGHT 0	DRAWING NO C=2301841	RESTRICTED TO -
1 PLC ± 0.25				
2 PLC ± 0.15				
3 PLC ± -				
4 PLC ± -				
ANGLES ± -				
FINISH		SCALE 1:1 SHEET 3 of 4 REV E1		
MATERIAL		CUSTOMER DRAWING		

REVISIONS

P	LTR	DESCRIPTION	DATE	DWN	APVD
-	-	SEE SHEET 1	-	-	-

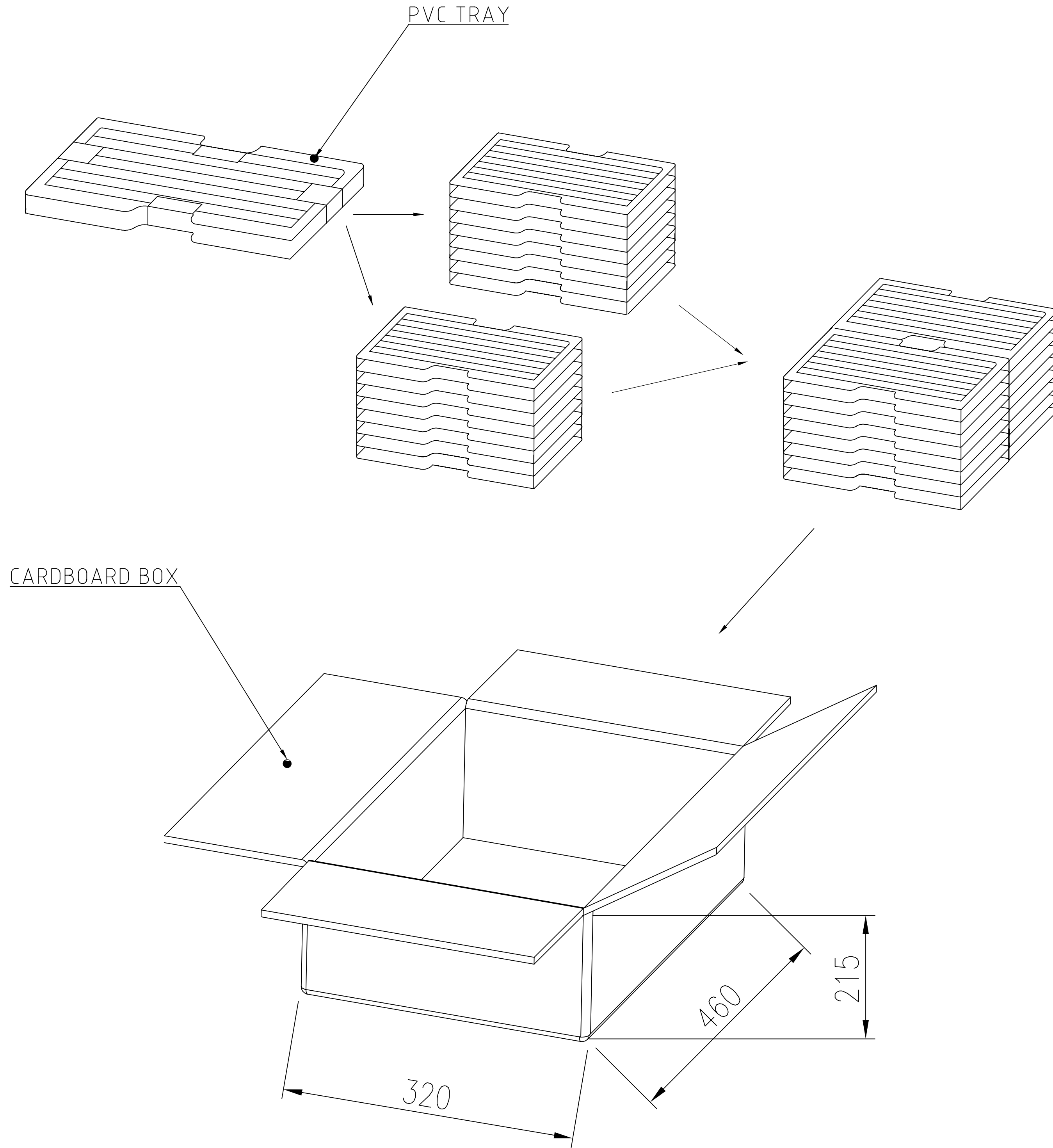

15.979	13.400	50	20	1000	2301841-2
14.479	11.900	50	20	1000	2301841-1
GROSS WEIGHT (Kg)	NET WEIGHT (Kg)	PCS/TRAY	TRAYS /CARTON	QUANTITY PCS	PART NUMBER

THIS DRAWING IS A CONTROLLED DOCUMENT.		DWN AJITH PAI 07FEB2017	TE Connectivity Ltd.		
DIMENSIONS: mm		CHK DAN GORENC 07FEB2017			
TOLERANCES UNLESS OTHERWISE SPECIFIED:		APVD - 07FEB2017	NAME D-SUB VERTICAL 25P SKT CONNECTOR		
0 PLC ± - 1 PLC ± 0.25 2 PLC ± 0.15 3 PLC ± - 4 PLC ± - ANGLES ± -		PRODUCT SPEC 108-130013	SIZE A2	CAGE CODE 00779	DRAWING NO C=2301841
MATERIAL -		FINISH -	WEIGHT 0	RESTRICTED TO -	
CUSTOMER DRAWING			SCALE 1:1	SHEET 4 of 4	REV E1