

25 PIN
SHOWN

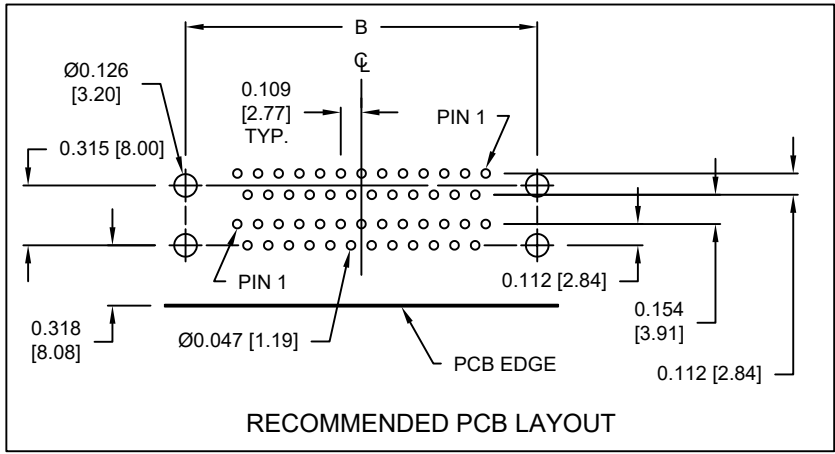
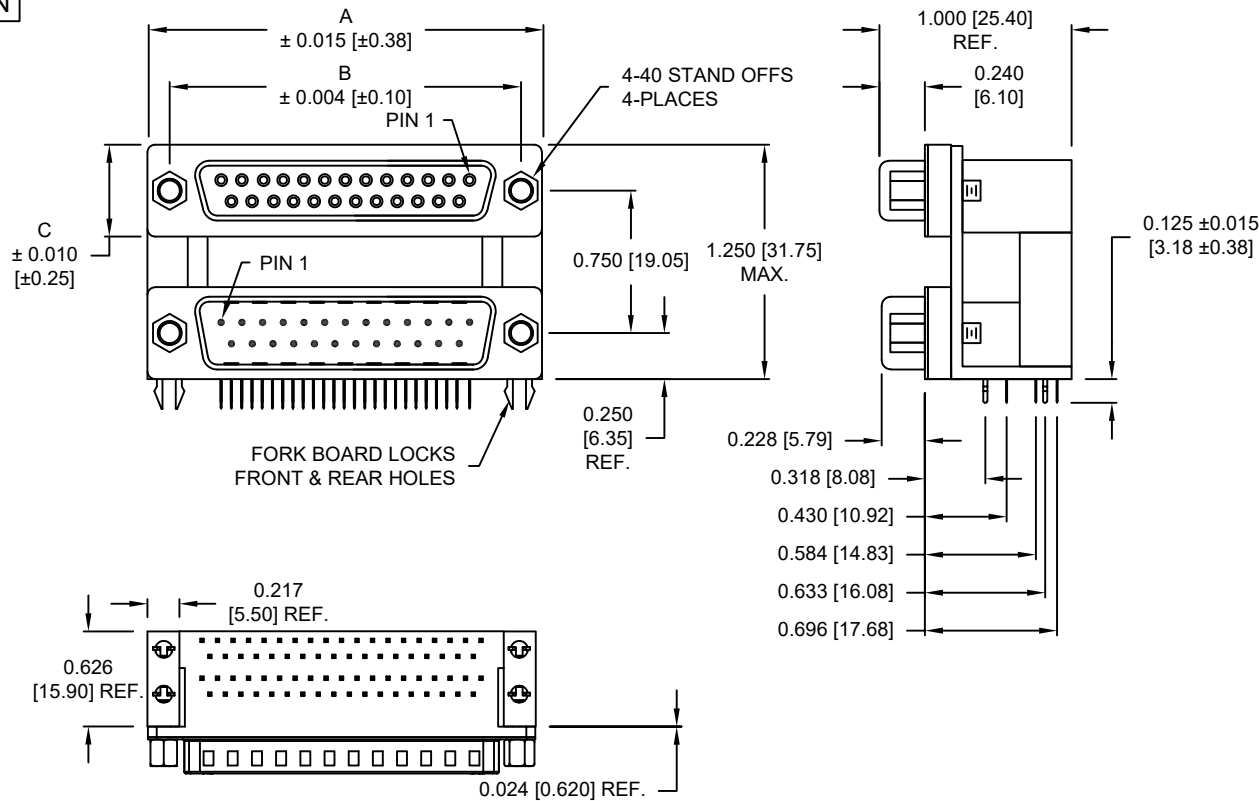

SPECIFICATIONS:

MATERIALS:

HOUSING: UL94 V-0 RATED, BLACK PA9T, 260° PROCESS TEMP.
 CONTACTS: GOLD PLATED BRASS (SEE P/N KEY BELOW)
 SHELL: NICKEL PLATED STEEL

ELECTRICAL:

RATED CURRENT: 5A
 INSULATOR RESISTANCE: 1,000 Ohms MIN.
 DIELECTRIC STRENGTH: 1,000 VAC RMS
 WORKING VOLTAGE: 250V
 OPERATING TEMPERATURE: -55°C TO +105°C

DIMENSIONS:

	9	15	25	37
A	1.204 [30.58]	1.535 [38.99]	2.078 [52.78]	2.724 [69.19]
B	0.984 [24.99]	1.312 [33.32]	1.850 [46.99]	2.500 [63.50]
C	0.494 [12.55]	0.494 [12.55]	0.494 [12.55]	0.494 [12.55]

178-YYY-313R571

SERIES _____
 POSITIONS _____
 009
 015
 025
 037
 GENDER _____
 31 = FEMALE OVER MALE
 41 = MALE OVER FEMALE
 51 = FEMALE OVER FEMALE
 61 = MALE OVER MALE
 SHELL PLATING _____
 3 = NICKEL
 HARDWARE OPTIONS _____
 57 = 4-40 STAND OFFS/BOARD LOCKS
 PLATING OPTIONS _____
 1 = SELECTIVE (GF MATING AREA / TIN PLATED TAILS)
 A = 30u" GOLD MATING AREA/GOLD FLASH TAILS
 9 = 30u" GOLD MATING AREA/TIN TAILS

RoHS COMPLIANT

UNITS = inch [mm]

DO NOT SCALE FROM DRAWING



THESE DRAWINGS AND SPECIFICATIONS ARE THE PROPERTY OF NorComp AND SHALL NOT BE REPRODUCED, COPIED OR USED AS THE BASIS FOR THE MANUFACTURE OR SALE OF APPARATUS WITHOUT WRITTEN PERMISSION.

DRAWN: C. SMITH
 DATE: 03/30/07

NorComp

SCALE: NTS	SHEET 1 OF 1	REV 9
DWG NO. 178-YYY-313R571		