

Oct.1.2024 Copyright 2024 HIROSE ELECTRIC CO., LTD. All Rights Reserved.  
In case of consideration for using Automotive equipment / device which demand high reliability, kindly contact our sales window correspondents.

1 CHART-1 POLARIZATION

No. 1	(+)	POWER
No. 2	(+)	SIGNAL
No. 3	(-)	POWER

2 CONNECTOR UNIT

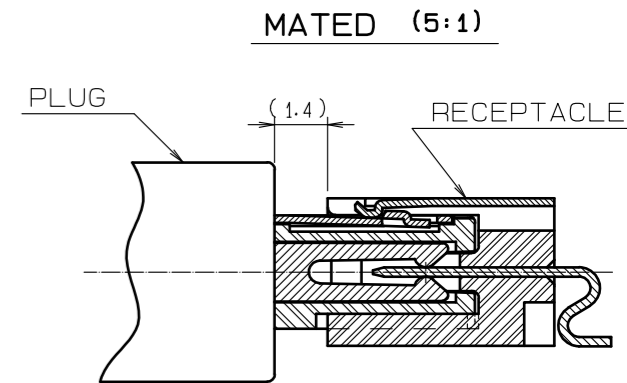
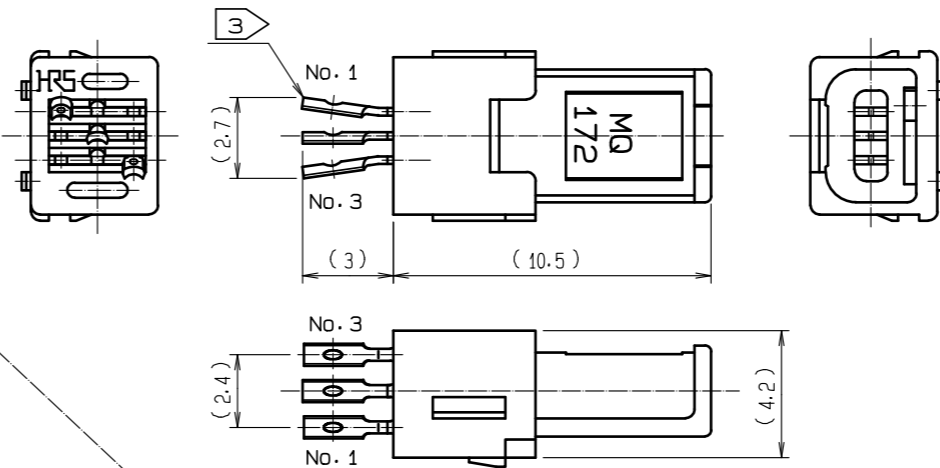

CONSTRUCTION (REFERENCE)

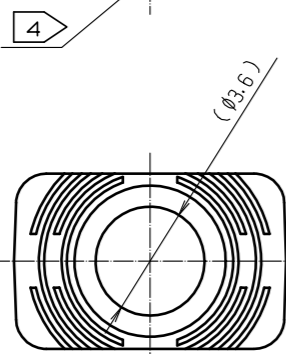
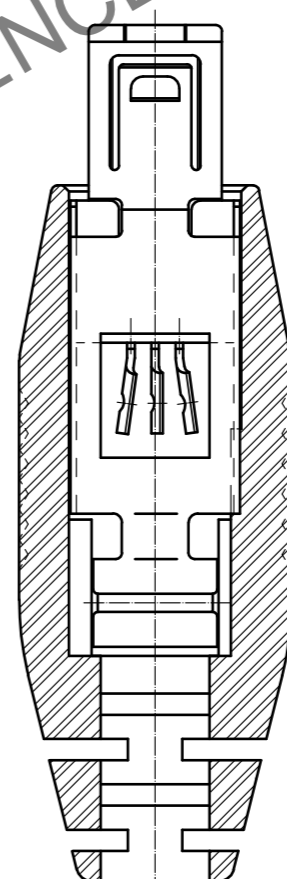
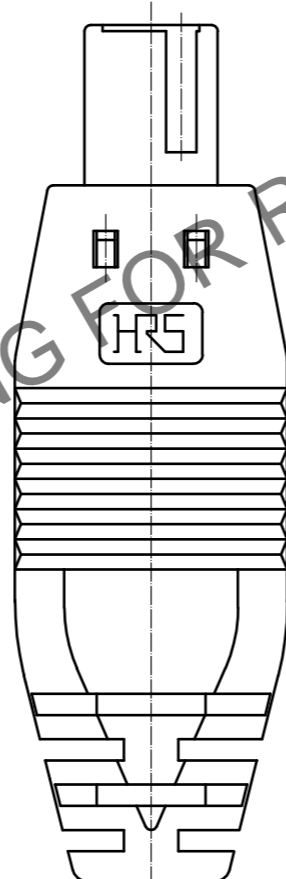
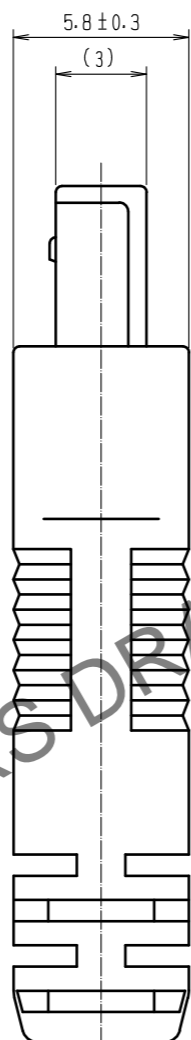
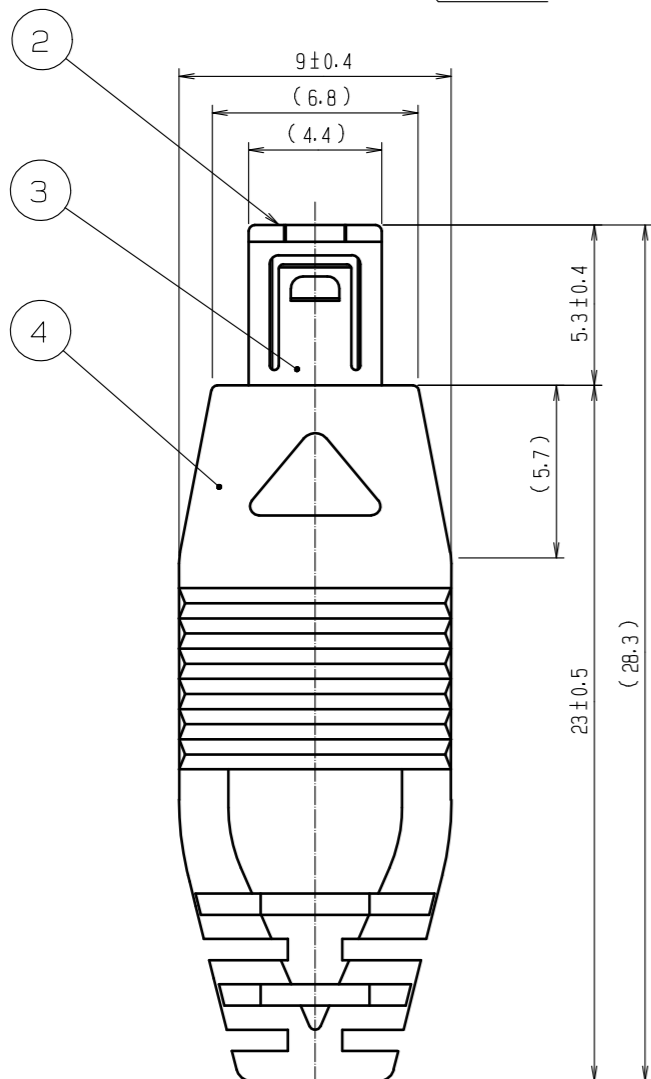
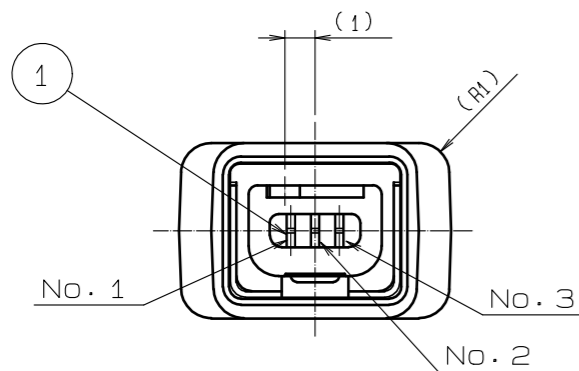
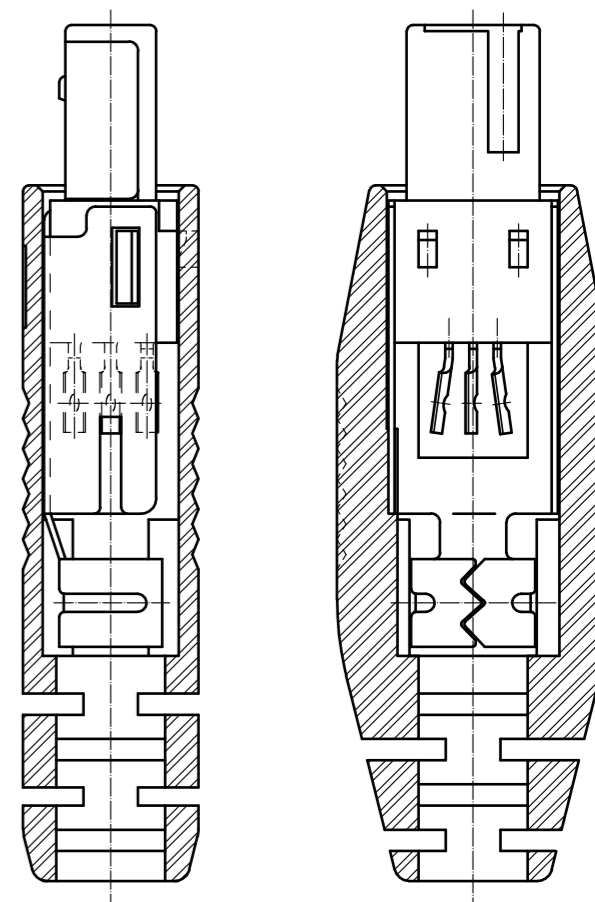

NOTES

- 1 POLARIZATION IS AS SHOWN ON CHART-1.
- 2 COMPONENTS PART NO. 3 AND NO. 4 ARE APPENDED PRODUCTS EXCEPT CONNECTOR UNIT (ASSEMBLED COMPONENTS PART NO. 1 AND NO. 2).
- 3 TERMINAL AREA SHALL BE COVERED WITH SHRINKAGE TUBE AFTER SOLDERING.
- 4 PROJECTION OF GATE IS 0.8 MAX.
- 5 DIRECTIONS FOR USE.  
·PLEASE DO NOT USE FOR THE PURPOSE OF INTERRUPTING THE CURRENT.

1	COPPER ALLOY	CONTACT AREA : PALLADIUM-NICKEL 0.7μm + GOLD 0.2μm LEAD AREA : GOLD 0.03μm UNDER PLATING : NICKEL 1.27μm	4	POLYAMIDE	BLACK UL94V-2
			3	STAINLESS STEEL	
			2	POLYAMIDE	BLACK UL94V-0
NO.	MATERIAL	FINISH . REMARKS	NO.	MATERIAL	FINISH . REMARKS
UNITS		SCALE	DESCRIPTION OF REVISIONS		
mm		4 : 1	DESIGNED	CHECKED	DATE
<b>HRS</b> HIROSE ELECTRIC CO., LTD.		APPROVED : NM. NISHIMATSU 15.10.27	DRAWING NO. EDC-120678-30-00		
		CHECKED : KN. ICHIKAWA 15.10.27	PART NO. MQ172-3SA-CV(30)		
		DESIGNED : TS. ITO 15.10.27	CODE NO. CL206-0951-7-30		
		DRAWN : AK. AKIYAMA 15.10.27	1/1		