

Material :

- * Base: High temperature plastic UL 94V-0, Color Nature
- * Cover: High temperature plastic UL 94V-0, Color Black
- * Contact: Phosphor Bronze
- * Fixed tab: Phosphor Bronze with 2.50um(100u") Min. Matte Tin Plated over 1.27um(50u") Min. Nickel

Ordering Code

CF35 ** * D 0 RM -NH
 ① ② ③ ④ ⑤ ⑥ ⑦

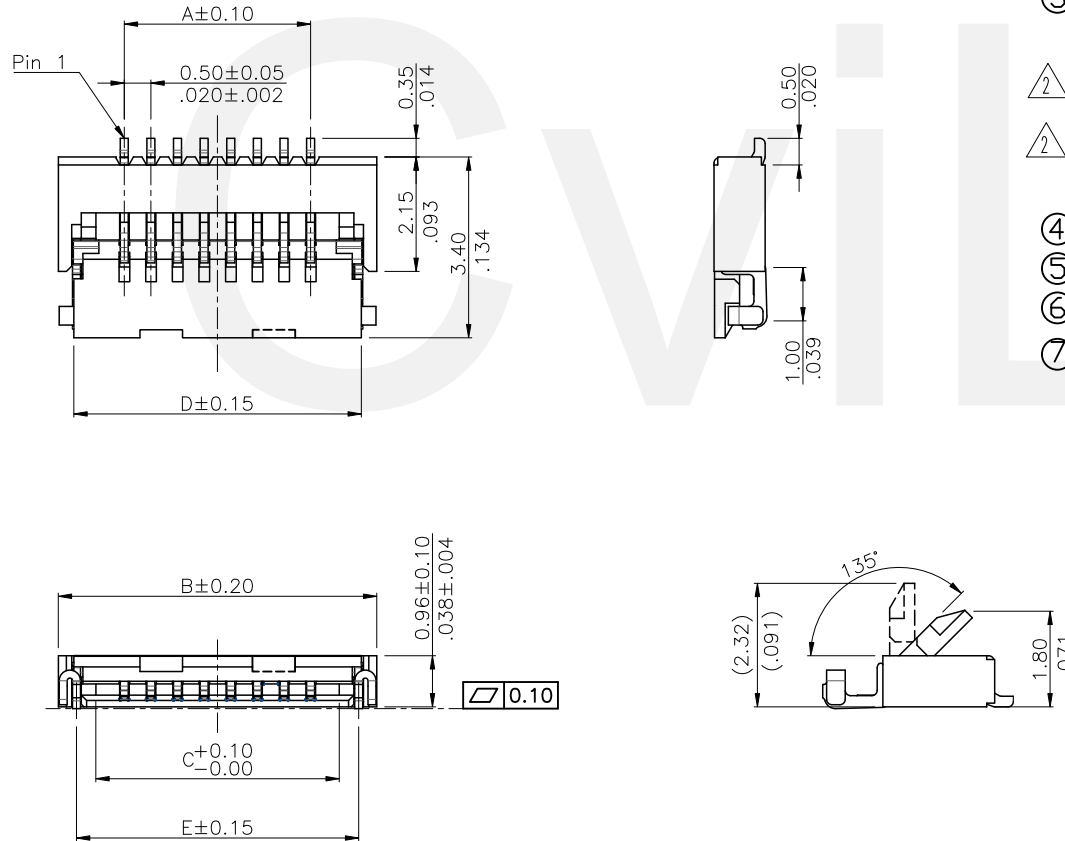
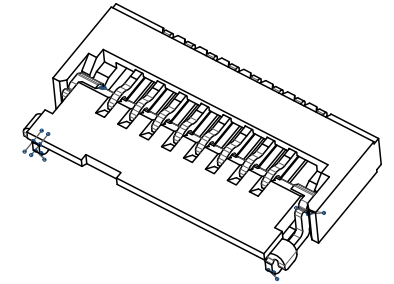

- ① Series No.
- ② No. of Circuits 4~30PIN
- ③ Plating code:
 - 1= 80u"~120u"Matte Tin plated over , 50u"~80u"Min.Nicke.
 - △ 2= 0.02um(0.8u")Min.Gold Flash on Contact area and Solder tails, 1.27um(50u") Min. Nickel Underplating over all.
 - △ F= 0.02um(0.8u")Min.Gold Flash on Contact area and Solder tails, 1.27um(50u") Min. Nickel Underplating over all.
- ④ Contact style: D= Downside contact
- ⑤ 0= Color Nature
- ⑥ Packing: RM= Tape & Reel packing
- ⑦ -NH= For Lead Free Reflow Processed and Halogen Free

DIM A=0.5 X (No. of Circuits-1)
 DIM B=DIM A+2.50
 DIM C=DIM A+1.10
 DIM D=DIM A+1.90
 DIM E=DIM A+1.80

Halogen-Free Lead Free Process RoHS Compliant

④					DATE	UNIT: mm / inch	TITLE: 0.50mm(.020") ZIF FFC/FPC ONE-TOUCH CONNECTOR
③				DRAWN BY: Ya	9/20-25'	TOLERANCE UNLESS OTHERWISE SPECIFIED	MATERIAL:
②	Ya	9/20-25'	ECRH125014/ECNT125160	ENGINEER: Ya	9/20-25'	.X ± 0.20/.008 .X' ±	
①	yanxu	4/19-19'	ECRH119016/ECNT119089	CHECKED BY: Kevin	9/20-25'	.XX ± 0.15/.006 .X' ± 1'	
SYM	NAME	DATE	REVISIONS	APPROVED BY: Kevin	9/20-25'	.XXX ± .XX' ±	

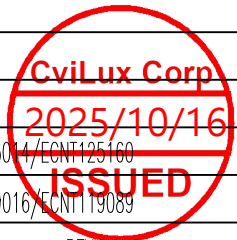

瀚荃股份有限公司
CviLux Corporation

DRAWING NO.	CF3527SB	PART NO.	CF35***DORM-NH
SCALE	1 / 1	SHEET	1 OF 3

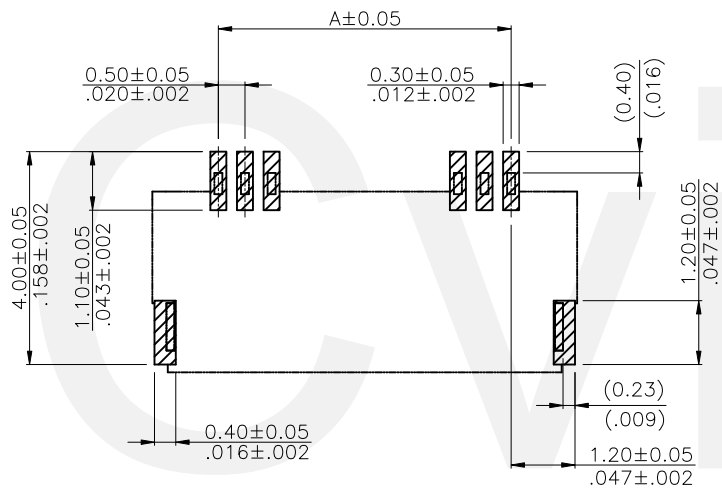

Recommended P.C. Board Layout

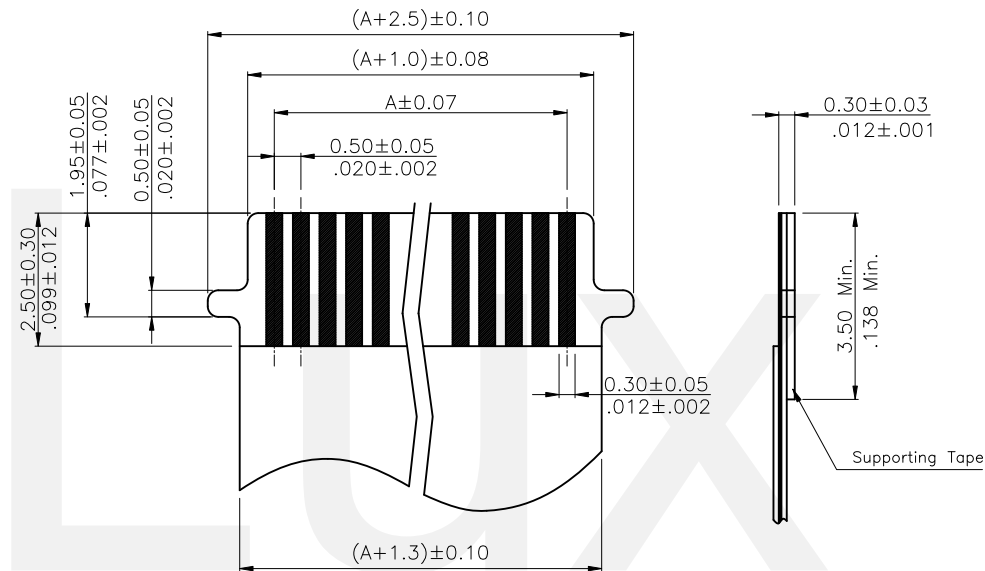

Accommodated FFC/FPC

Halogen-Free

Lead Free Process

RoHS Compliant

4						
3						
2	Ya	9/20-25	ECRH125014/ECNT125160			
1	yanxu	4/19-19	ECRH119016/ECNT119089			
SYM	NAME	DATE	REVISIONS			

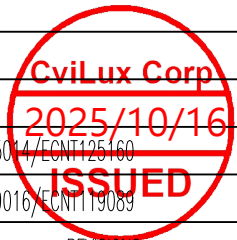

DRAWN BY:	Ya	9/20-25'
ENGINEER:	Ya	9/20-25'
CHECKED BY:	Kevin	9/20-25'
APPROVED BY:	Kevin	9/20-25'

UNIT:	mm / inch
TOLERANCE	UNLESS OTHERWISE SPECIFIED
.X	± 0.20/.008 X' ±
.XX	± 0.15/.006 .X' ± 1'
.XXX	± .XX' ±

TITLE:	0.50mm(.020") ZIF FFC/FPC ONE-TOUCH CONNECTOR
MATERIAL:	
FINISH:	



瀚荃股份有限公司
CviLux Corporation

DRAWING NO.	CF3527SB	PART NO.	CF35***DORM-NH
SCALE	1 / 1	SHEET	2 OF 3

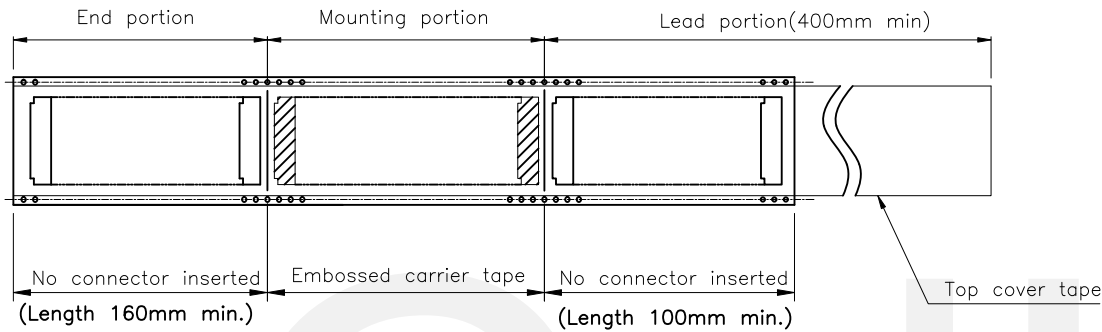

TAPE RUNNING DIRECTION

Notes:

1. Reel Material : HIPS
2. 10 sprocket hole pitch cumulative tolerance ± 0.2
3. Camber not to exceed 1mm in 100mm.
4. Material: Polystyrene.
5. Pocket position relative to sprocket hole measured as true position of pocket, not pocked hole.
6. All dimensions meet EIA-481-B requirements.
7. Quantity: 3000 PCS/REEL

Circuits	Dimension					Packing (Reel/Caton)
	E	F	W1	W2	W3	
4-11	16.0(.630)	7.50(.295)	16.5(.650)	22.5(.885)	16.5(.650)	11
12-29	24.0(.945)	11.50(.453)	24.5(.965)	30.5(1.200)	24.5(.965)	9
30	32.0(1.260)	14.20(.559)	32.5(1.280)	38.5(1.516)	32.5(1.280)	7

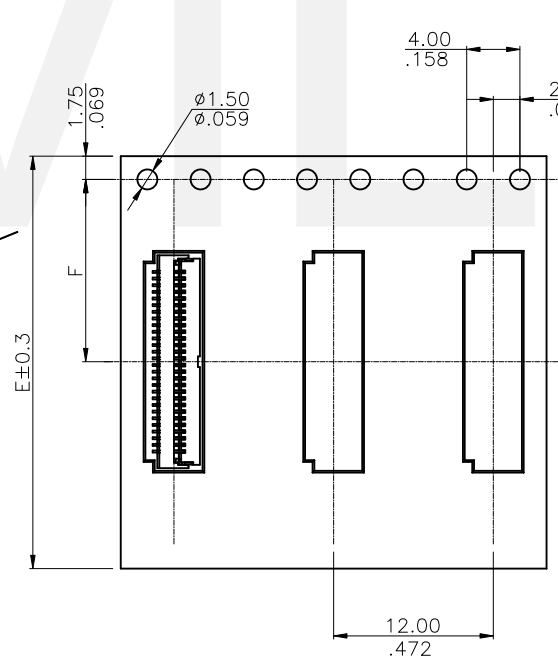
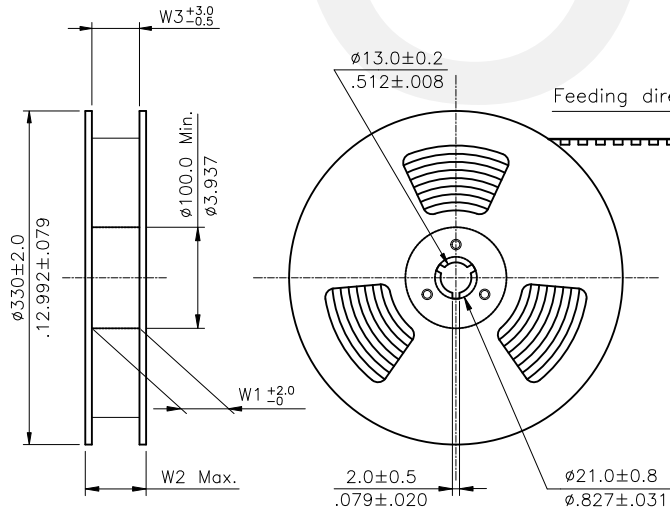

WIDTH : 16,24 mm Carrier
(SCALE 1:4)

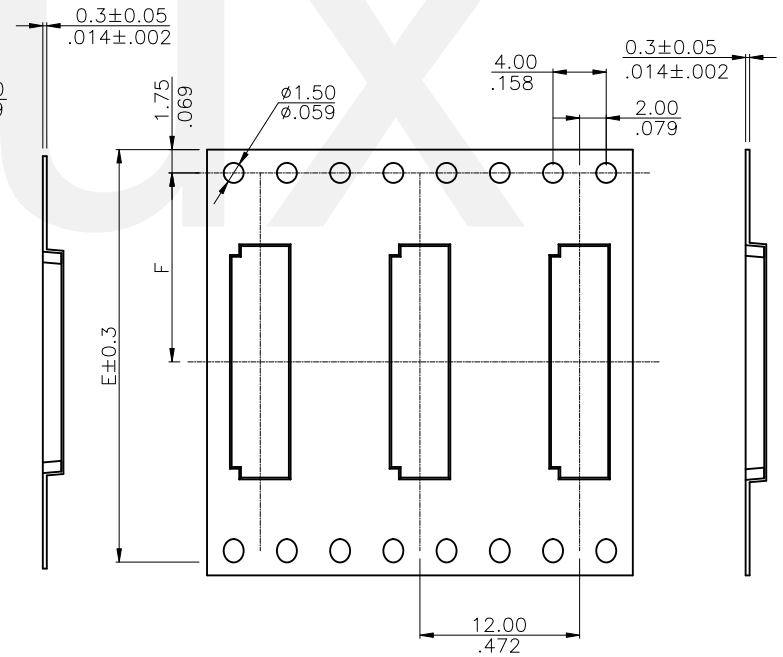

WIDTH : 32,44 mm Carrier
(SCALE 1:4)

RoHS Compliant

4					DATE	UNIT: mm / inch	TITLE: 0.50mm(.020") ZIF FFC/FPC ONE-TOUCH CONNECTOR
3					DRAWN BY: Ya	9/20-25'	TOLERANCE UNLESS OTHERWISE SPECIFIED
2	Ya	9/20-25'	ECRH125014/ECNT125160		ENGINEER: Ya	9/20-25'	
1	yanxu	4/19-19'	ECRH119016/ECNT119089		CHECKED BY: Kevin	9/20-25'	MATERIAL:
SYM	NAME	DATE	REVISIONS		APPROVED BY: Kevin	9/20-25'	FINISH:

CviLux Corp
2025/10/16
ISSUED

瀚荃股份有限公司
CviLux Corporation

DRAWING NO.	CF3527SB	PART NO.	CF35***DORM-NH
SCALE	1 / 1	SHEET	3 OF 3