

REVISIONS				
REV	DESCRIPTION	DATE	BY	APPV
U2	ECR-26-269705	02FEB2026	ABS	PS

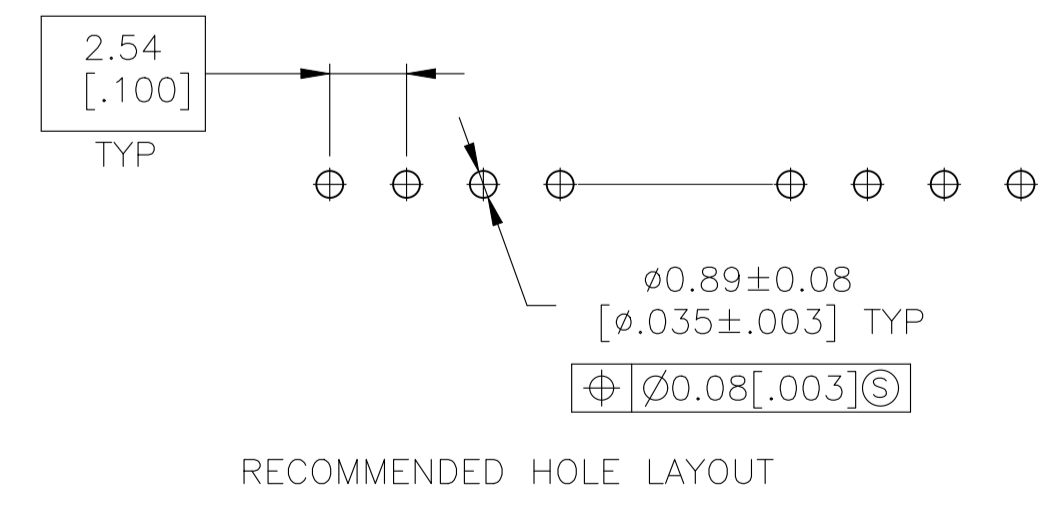
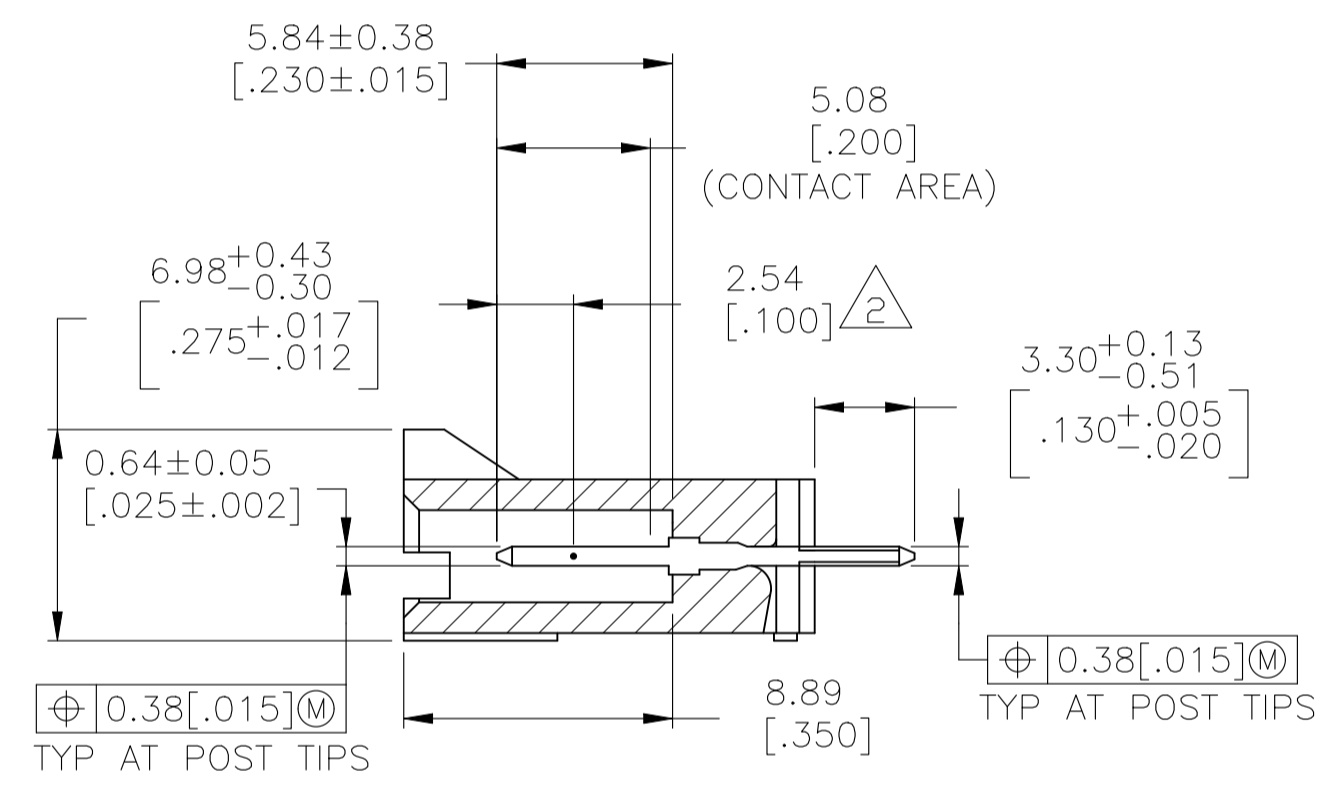
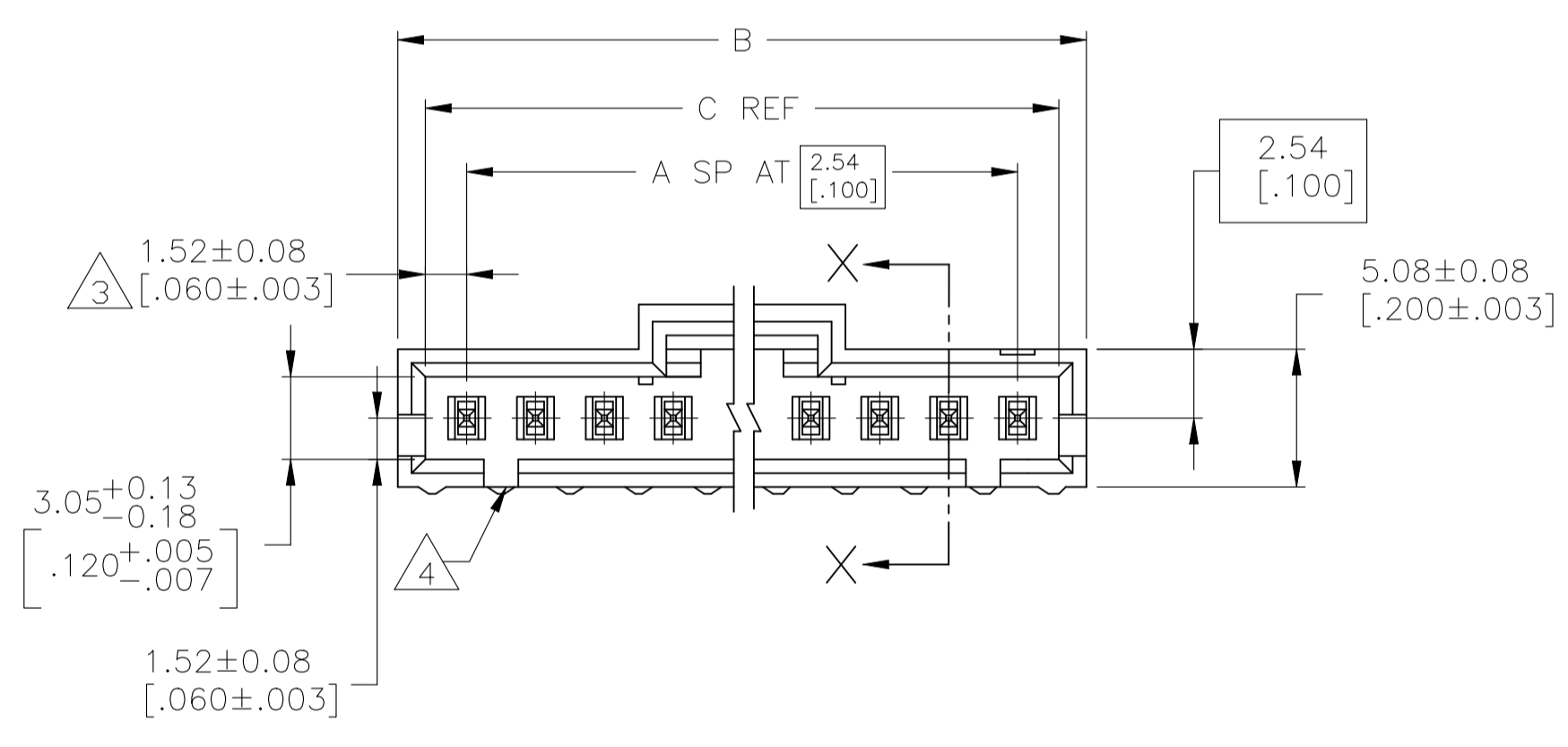
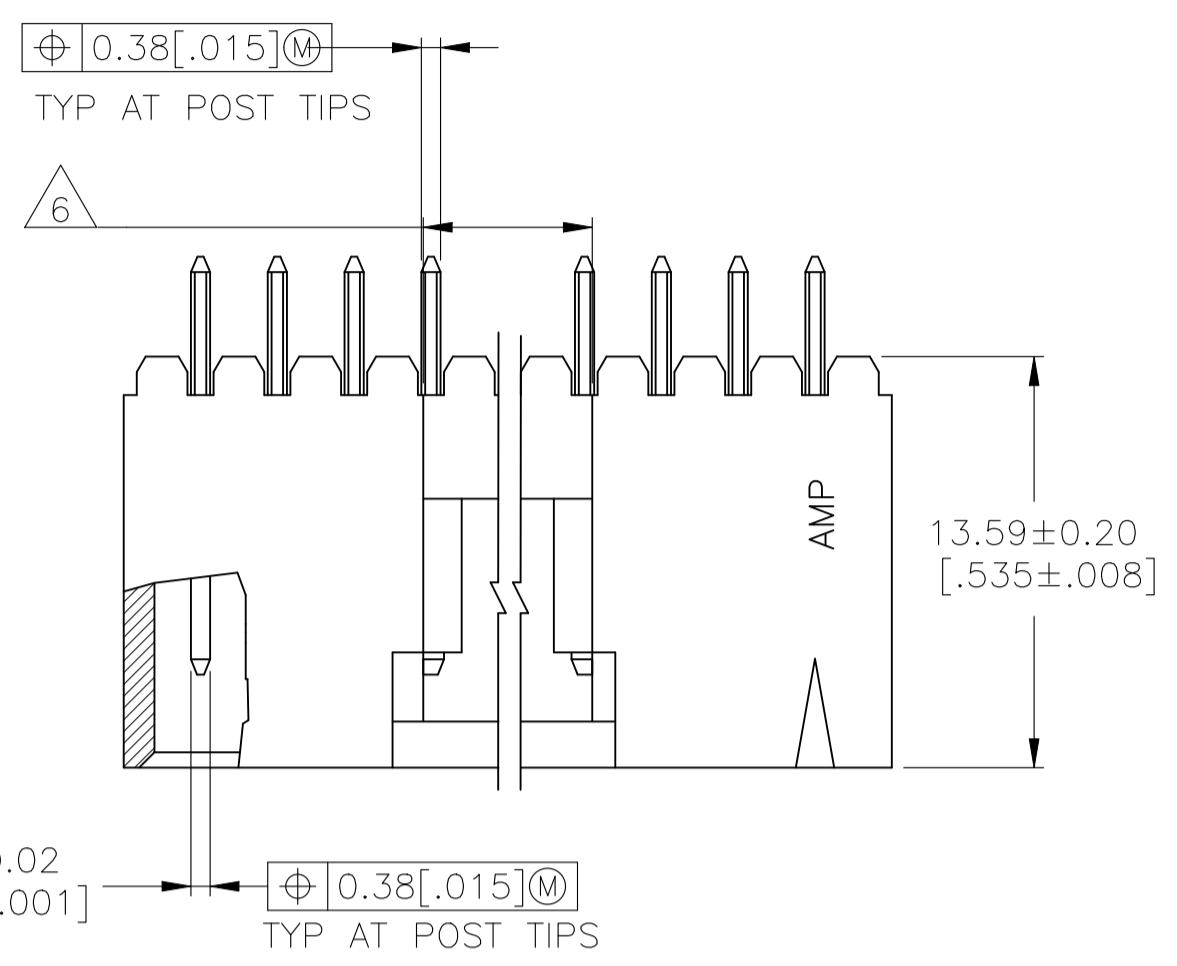

- 1 .00038[.000015] GOLD IN THE CONTACT AREA, .00254[.000100] MATTE TIN-LEAD ON REMAINDER OF CONTACT, ALL OVER .00127[.000050] NICKEL.
- 2 POINT OF MEASUREMENT FOR PLATING THICKNESS.
- 3 THE NOTED DIMENSIONS APPLY AT THE INTERSECTION OF THE POST AND THE HOUSING.
- 4 ON ASSEMBLIES WITH FOUR OR MORE POSITIONS, TWO POLARIZATION SLOTS. ON ASSEMBLIES WITH TWO OR THREE POSITIONS, ONE POLARIZATION SLOT.
- 5 OBSOLETE PARTS: OBSOLETE CIS STREAMLINING PER D.RENAUD/D.SINISI
- 6 0.25 [.010] RECESS PERMISSIBLE IN THIS AREA FOR MOLD SHUT OFF

5	OBSOLETE	64.01 [2.520]	65.91 [2.595]	24	25	2-103638-4-
5	SUPERSEDED BY 7-104910-3	61.47 [2.420]	63.37 [2.495]	23	24	2-103638-3
5	OBSOLETE	58.93 [2.320]	60.83 [2.395]	22	23	2-103638-2-
		56.39 [2.220]	58.29 [2.295]	21	22	2-103638-1-
5	OBSOLETE	53.85 [2.120]	55.75 [2.195]	20	21	2-103638-0-
		51.31 [2.020]	53.21 [2.095]	19	20	1-103638-9
5	OBSOLETE	48.77 [1.920]	50.67 [1.995]	18	19	1-103638-8-
		46.23 [1.820]	48.13 [1.895]	17	18	1-103638-7
		43.69 [1.720]	45.59 [1.795]	16	17	1-103638-6
		41.15 [1.620]	43.05 [1.695]	15	16	1-103638-5
		38.61 [1.520]	40.51 [1.595]	14	15	1-103638-4
		36.07 [1.420]	37.97 [1.495]	13	14	1-103638-3
		33.53 [1.320]	35.43 [1.395]	12	13	1-103638-2
		30.99 [1.220]	32.89 [1.295]	11	12	1-103638-1
		28.45 [1.120]	30.35 [1.195]	10	11	1-103638-0
		25.91 [1.020]	27.81 [1.095]	9	10	103638-9
		23.37 [.920]	25.27 [.995]	8	9	103638-8
		20.83 [.820]	22.73 [.895]	7	8	103638-7
		18.29 [.720]	20.19 [.795]	6	7	103638-6
		15.75 [.620]	17.65 [.695]	5	6	103638-5
		13.21 [.520]	15.11 [.595]	4	5	103638-4
		10.67 [.420]	12.57 [.495]	3	4	103638-3
		8.13 [.320]	10.03 [.395]	2	3	103638-2
		5.59 [.220]	7.49 [.295]	1	2	103638-1
		C	B	A	NO. OF POSN	PART NO.

THIS DRAWING IS A CONTROLLED DOCUMENT.

DIMENSIONS: mm [INCHES]	TOLERANCES UNLESS OTHERWISE SPECIFIED:	0. PLC ± -	1. PLC ± -	2. PLC ± 0.13[.005]	3. PLC ± -	4. PLC ± -	ANGLES ± -	DIN S. SHUEY 3-5-91	CHK: J. GESFORD 3-5-91	APVD: J. GESFORD 3-5-91	NAME:	TE Connectivity HDR ASSY, VERT, SINGLE ROW 2.54[.100] CL, 0.64[.025] SQ POST. WITHHOLDING, & AMP MODU MTE
MATERIAL: HOUSING: FLAME RETARDANT LSP COLOR: BLACK CONTACTS: BRASS	FINISH:	WEIGHT: -	SIZE: A1	CAGE CODE: 00779	DRAWING NO: 103638	RESTRICTED TO: -	CUSTOMER DRAWING	SCALE: 4:1	SHEET: 1 of 1	REV: U2		