

i All numerical values are in metric units [with U.S. customary units in brackets]. Dimensions are in millimeters. Unless otherwise specified, dimensions have a tolerance of ± 0.13 mm and angles have a tolerance of $\pm 2^\circ$. Figures and illustrations are for identification only and are not drawn to scale.

1. INTRODUCTION

This specification covers the requirements for application of the LUMAWISE Endurance S2 series connector system. This connector system is typically used for roadway lighting and sensing applications, as well as area lighting and sensing applications. The LUMAWISE Endurance S2 series is supplied as a 4 position contact system with all contacts being pre-installed into the receptacle. The LUMAWISE Endurance S2 Receptacle contacts are dual wire poke-in style termination contacts. Both standard and keyed versions are available.

When corresponding with TE Connectivity (TE) Personnel, use the terminology provided in this specification to facilitate inquiries for information. Basic terms and features of this product are provided in Figure 1.

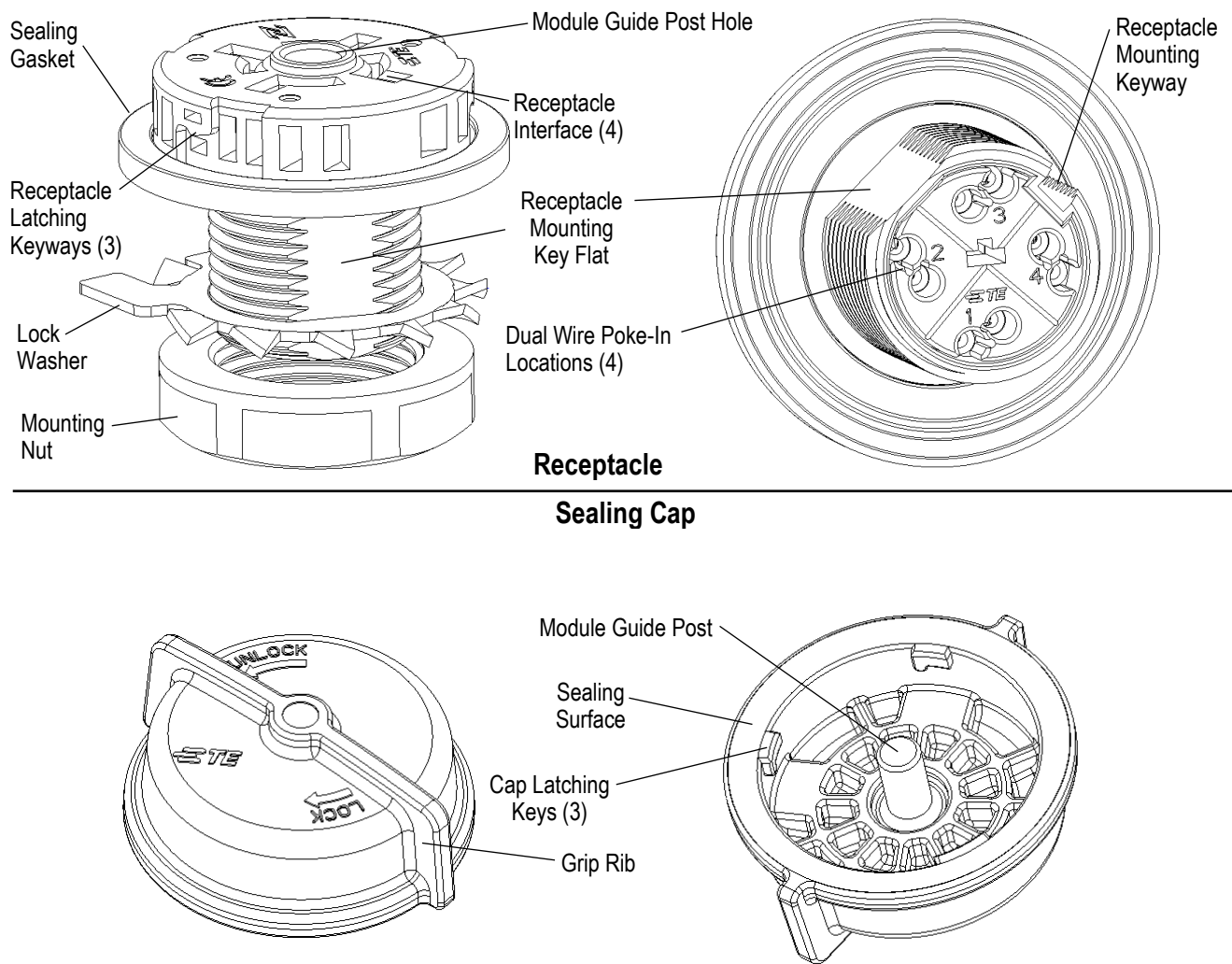

Figure 1

2. REFERENCE MATERIAL

2.1. Revision Summary

Rev 4. Changed Section 3.6 B to 26mm Hex Socket

2.2. Customer Assistance

Reference Product Base Part Numbers:

Receptacle Assembly – 2363638

Sealing Cap – 2213795, 2341474

Mating Module Base and Module Base Dome – see 114-133074

Product Code L937. Use of these numbers will identify the product line and help you to obtain product and tooling information when visiting www.te.com or calling the number at the bottom of this page.

2.3. Drawings

Customer drawings for product part numbers are available from www.te.com. Information contained in the customer drawing takes priority.

2.4. Specifications

Product Specification 108-160194 provides product performance and test information for the LUMAWISE Endurance S Gen 2 products.

3. REQUIREMENTS

3.1. Safety

Perform all electrical wiring of the receptacle with power turned OFF.

3.2. Limitations

The connectors are designed to operate in a temperature range of -40° to 90°C [-40° to 194°F].

3.3. Material

The receptacle housing, sealing cap, module bases, and domes are made of UL 94V-0 and UL UV-f1 rated thermoplastic. The locking nut is made of UL 94V-2 rated thermoplastic. The lock washer is stainless steel. The module blades contacts are made of brass plated overall with tin. Receptacle contacts are made of copper alloy plated with tin overall. Receptacle contact springs are stainless steel. Sealing gasket is silicon rubber.

3.4. Storage

A. Shelf Life

The product should remain in the shipping containers until ready for use to prevent deformation to components. The product should be used on a first in, first out basis to avoid storage contamination that could adversely affect performance.

B. Chemical Exposure

Do not store or use product near any chemical listed below as they may cause stress corrosion cracking in the material.

Alkalies	Ammonia	Citrates	Phosphates	Citrates	Sulfur Compounds
Amines	Carbonates	Nitrites	Sulfur	Nitrites	Tartrates

3.5. Handling

The receptacle assembly is supplied with the sealing gasket installed, with the lock washer and mounting nut bagged separately with the receptacle assembly. Sealing caps are supplied in bulk packaging. Module assemblies are supplied with o-ring and power contacts preinstalled; therefore, take precautions not to damage or misplace parts prior to assembly. Ensure receptacle sealing gasket and module O-ring are present prior to final assembly.

3.6. Receptacle Mounting

A. Gasket Verification

If the gasket becomes dislodged from the gasket seat on the receptacle body. Gasket must be installed with the smooth side of gasket towards the Receptacle Body, and the groove side of the gasket towards the threads. Gasket Lip must be slightly stretched over and around the receptacle gasket flange into the seating area. Gasket will be flat when fully installed into the gasket seat. As shown in Figure 2.

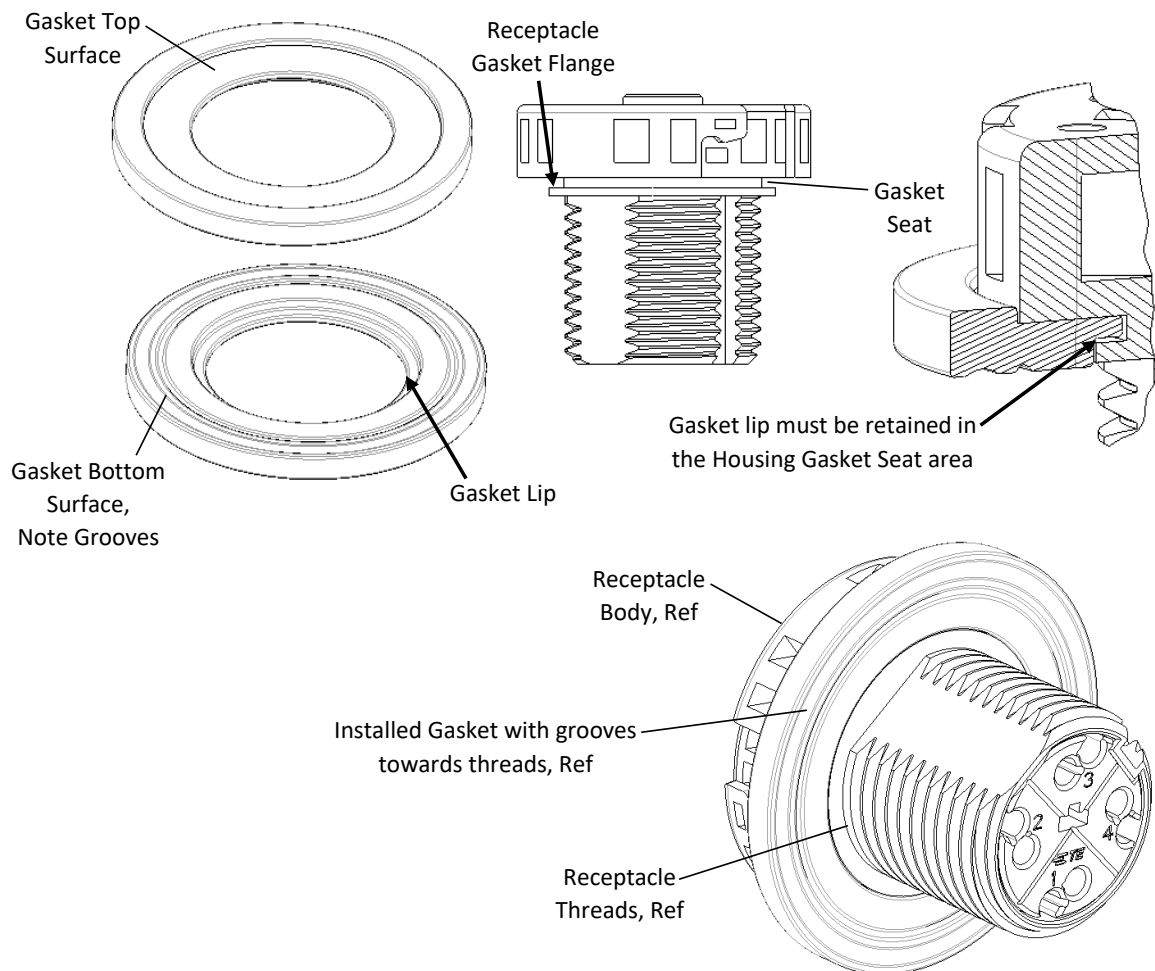

Figure 2

B. Mounting

A surface shall be provided on luminaire housing that is ideally flat. If a flat surface is not possible a secondary possibility is to have a flat surface in one direction and a minimum radius in the other of 500mm to mount the receptacle. To provide a water tight mounting seal, the luminaire surface must be free of dirt, debris, or burrs. Sealing gasket provided with the receptacle assembly must be used. Receptacle can be used on a luminaire housing thickness between 1.5mm to 6.0mm. When mounting receptacle assembly, it must not rotate during locking washer and locking nut application. Torque mounting nut within the range of 1.8 to 2.4 N-m using a 26mm hex socket. See Figure 3.

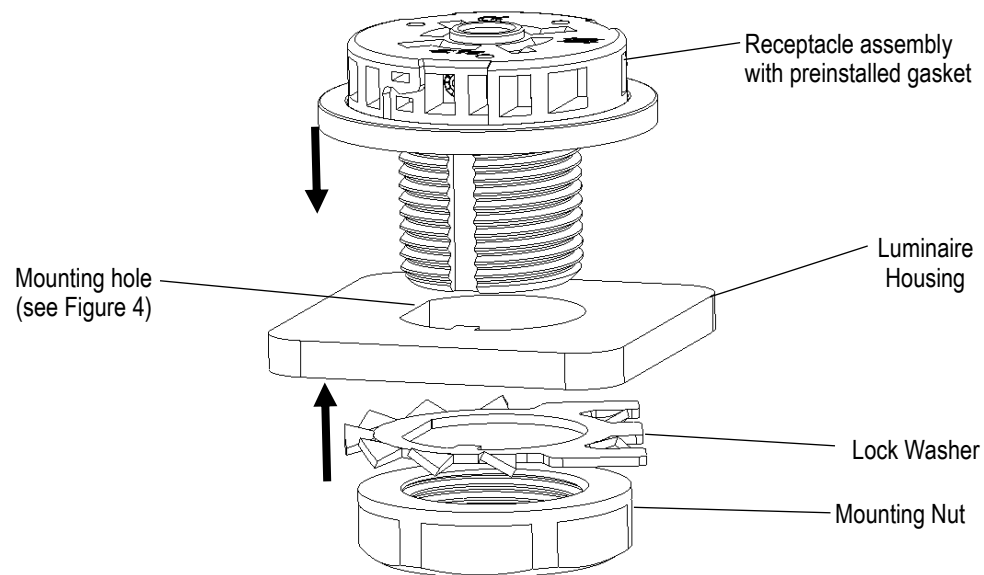

Figure 3

C. Mounting Hole Pattern

The recommended and Optional mounting hole is shown in Figure 4. Refer to product drawing for additional details.

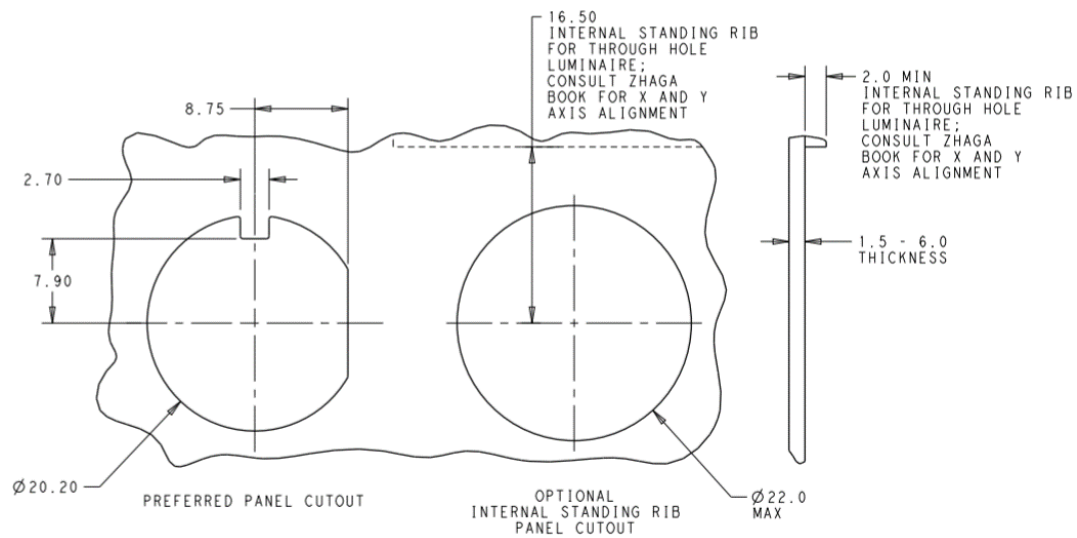

Figure 4



NOTE: Variations to the recommended mounting hole are possible but must be verified by the end user to ensure they do not result in excessive movement of the receptacle assembly during mounting or use. Excessive movement could result in reduced system performance. An absolute maximum hole diameter of 22.0mm should be used.

D. Mounting Location and Orientation

Locate the receptacle in any orientation based on your module operation requirements.

E. Workmanship

The receptacle housing and sealing gasket must not be damaged in anyway. There shall be no nicks or marks on gasket top and bottom surfaces.

3.7. Wire Connections

A. Wire Locations

The receptacle is wired on the bottom side of the assembly; access from the inside of the luminaire. Wire entry locations are labeled 1, 2, 3, and 4. Corresponding contact designations are marked the same on the module bases for PCB alignment. See Figure 5.

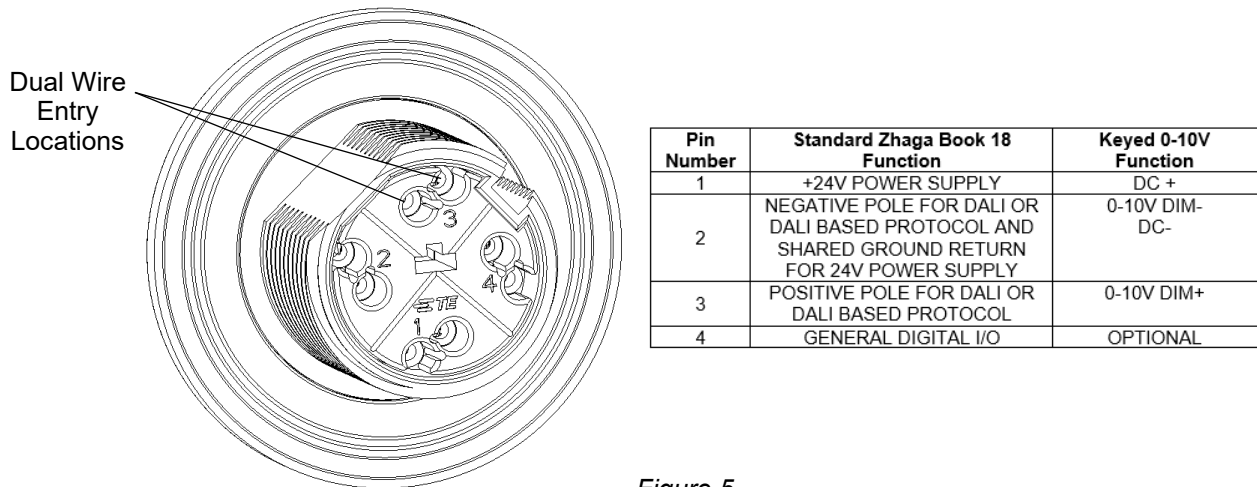
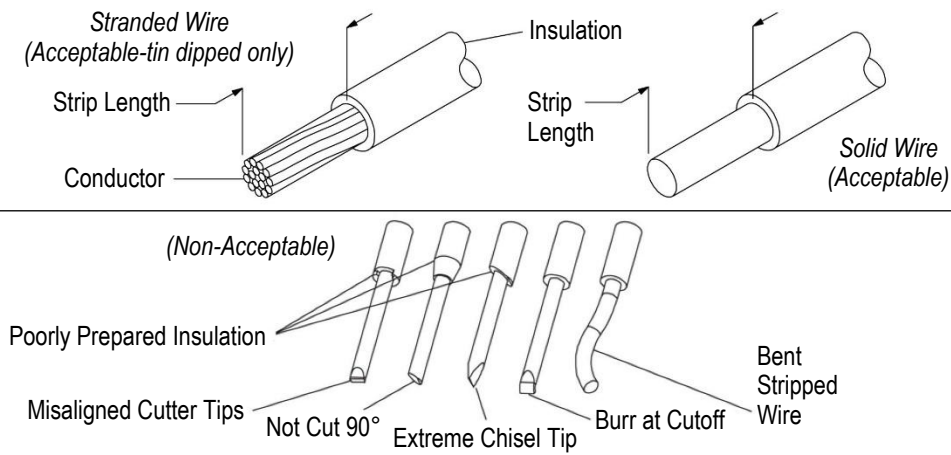

Figure 5

3.8. Wire Selection and Preparation

The receptacle assembly will accept 18 thru 20AWG solid and 18 thru 20AWG stranded tin-dipped copper wire only. The table in Figure 6 provides wire selection for the Poke-In Connectors. See Figure 6.



RECOMMENDED WIRE			
WIRE SIZE	WIRE TYPE	INSULATION DIAMETER	STRIP LENGTH
18AWG	SOLID	Ø2.35 MAX Ø1.50 MIN	11.0±1.0mm
	STRANDED (TIN DIPPED)		
20AWG	SOLID		
	STRANDED (TIN DIPPED)		

Figure 6

NOTE

Recommended maximum insulation diameter should be as provided in Figure 6. Wires with larger insulation diameters will not fit within the housing's poke-in hole insulation tunnel. Wires utilizing semi-rigid insulation are recommended to minimize movement of the insulation along the axis of the wire. Movement of the insulation will result in variation of the wire strip length which can lead to incorrect wire termination.

3.9. Wire Termination

The receptacles must be terminated according to the following instructions.

A. Workmanship

CAUTION

The housing must not be damaged in any way. There shall be no bending of the contacts. There shall be no exposed copper wire or broken or bent conductor strands.

B. Wire Insertion

All wires must be pushed firmly inside the contact wire openings. The wires must be fully inserted so that the wire insulation is inserted between three and five millimeters into the rear of the housing. Refer to Figure 7.

C. Wire Termination Depth

The required wire termination depth is achieved when the wire has bottomed in the connector housing. Connector design has an internal wire stop. Refer to Figure 7

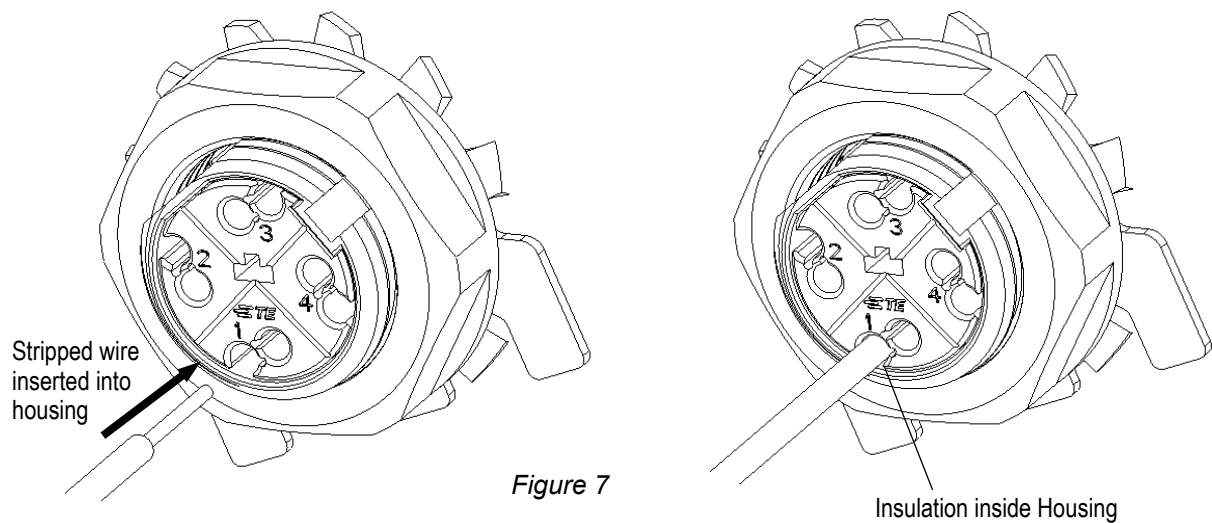

D. Wire Extraction

A fully inserted wire can be extracted from the receptacle using a tool and the release tool hole located on between the dual wire insertion locations on the receptacle housing. Using tool tip that is 0.7mm diameter and 16.0mm long, insert it into the hole (one per wire) and open the contact beam. The wire may then be extracted from the connector along the axis of wire insertion direction. Release tool, described above, can be held in a commercially available small pin vise for ease of handling. Refer to Figure 8.



CAUTION: Extraction device to be free from burrs and sharp edges to ensure no damage is done to connector terminals.

CAUTION: A new stripped wire must be re-inserted into cavity after extraction of existing wire. DO NOT re-use extracted wire.



DANGER: Extreme caution to ensure there is no power in the system prior to insertion of wire extraction device.

Exercise extreme care to avoid electrical shock or system damage

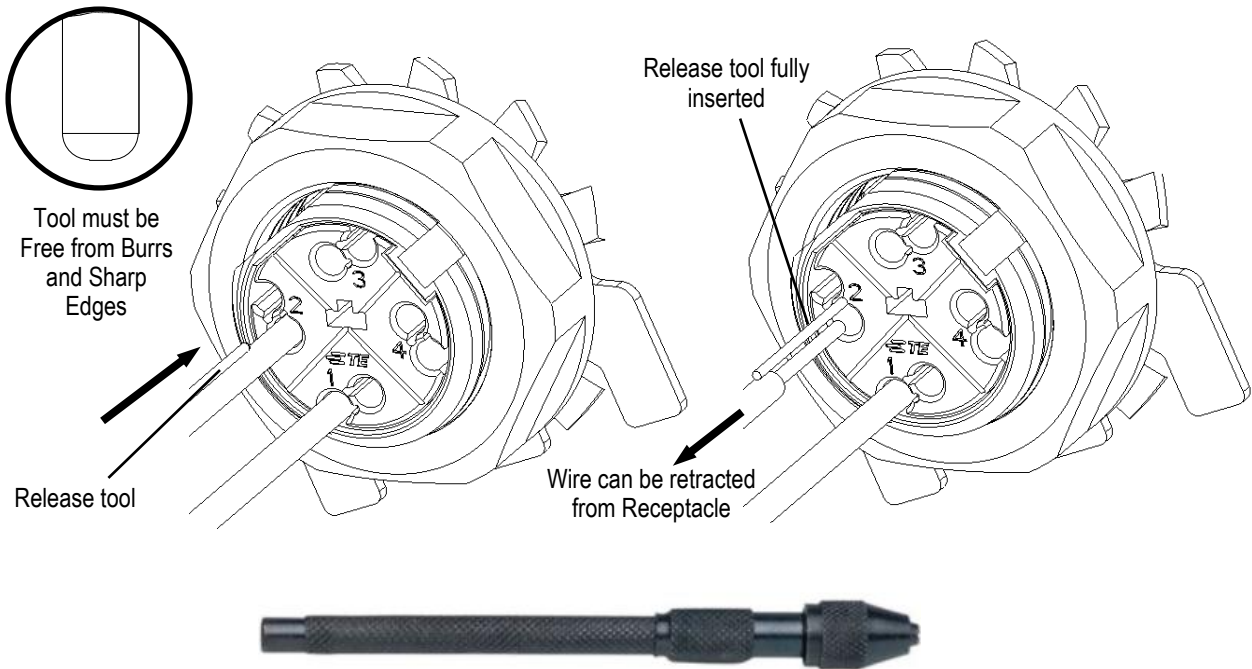

Figure 8

3.10. Strain Relief

It is recommended that a means be provided to support the wire bundle extending away from the receptacle assembly to prevent inadvertent application of high force to the wire bundle from transmitting into the wire/connector interface. The suggested strain relief method is to use a cable tie and anchor mounted inside the luminaire.

3.11. Mating and Un-mating Module and/or Sealing Cap to Receptacle

Align the Module or Sealing Cap over the mounted receptacle. Based on polarizing features on each, the Module or Sealing Cap can only be installed in one position. Lightly rotate the Module or Sealing Cap until you feel the alignment keys and the blades align to the proper location. After alignment, push downward until the Module or Sealing Cap is bottomed on the receptacles mating face. Then complete mating by rotating Module or Sealing Cap with downward pressure while twisting in a clockwise direction. The Module or Sealing Cap will lock into position with an audible 'click'. To un-mate, gently push down and reverse the aforementioned mating process. Refer to Figure 9.



CAUTION

When in field use it is important that a receptacle is mated to either the specified sealing cap or a module assembly. The receptacle by itself is not a sealed device and would allow moisture to enter the luminaire.



NOTE

It is recommended that the luminaire design incorporates a breathable vent. The use of a vent will help to equalize pressure changes within the luminaire which will intern help to maintain the integrity of the sealing capability of the connector system.

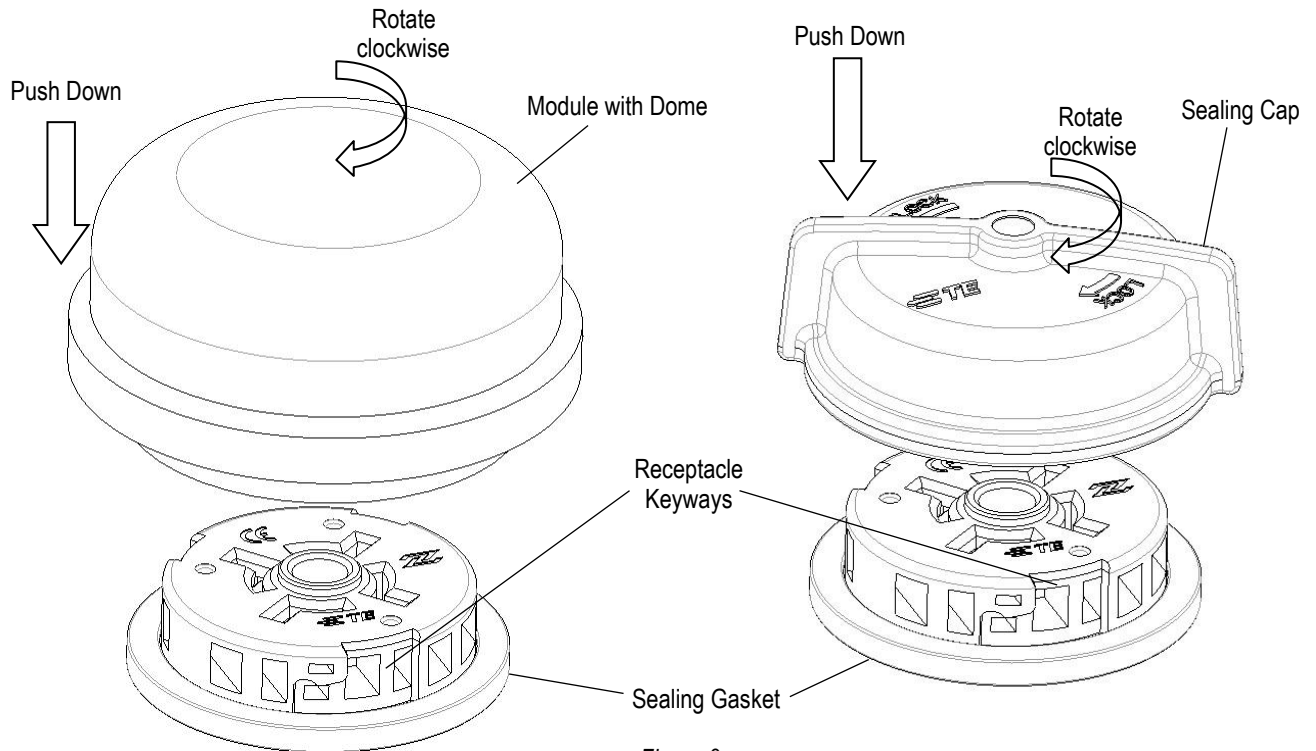

Figure 9

3.12. Replacement and Repair

The contacts and housings are not repairable. DO NOT use an assembly with damaged or defective contacts and/or housings. If damaged, replace the receptacle assembly or module assembly with a new one.

4. QUALIFICATIONS

LUMAWISE Endurance S2 connectors are component recognized by Underwriters Laboratories, Inc. in File E66375, Volume 7, and have been investigated to CSA International by UL.



NOTE

UL UV-f1 outdoor rated plastics in accordance with UL 746C are used for the LUMAWISE Endurance S2 connector system.

LUMAWISE Endurance S2 connectors are being evaluated to IEC-61984 by Underwriters Laboratories, Inc. and is included in CB report certificate US-TBD.

LUMAWISE Endurance S2 non-keyed connectors are Zhaga Book 18 compliant.

5. VISUAL AID

The illustration below shows a typical application of LUMAWISE Endurance S2 product. This illustration should be used by production personnel to ensure a correctly applied product. Applications which DO NOT appear correct should be inspected using the information in the preceding pages of this specification and in the instructional material shipped with the product or tooling.

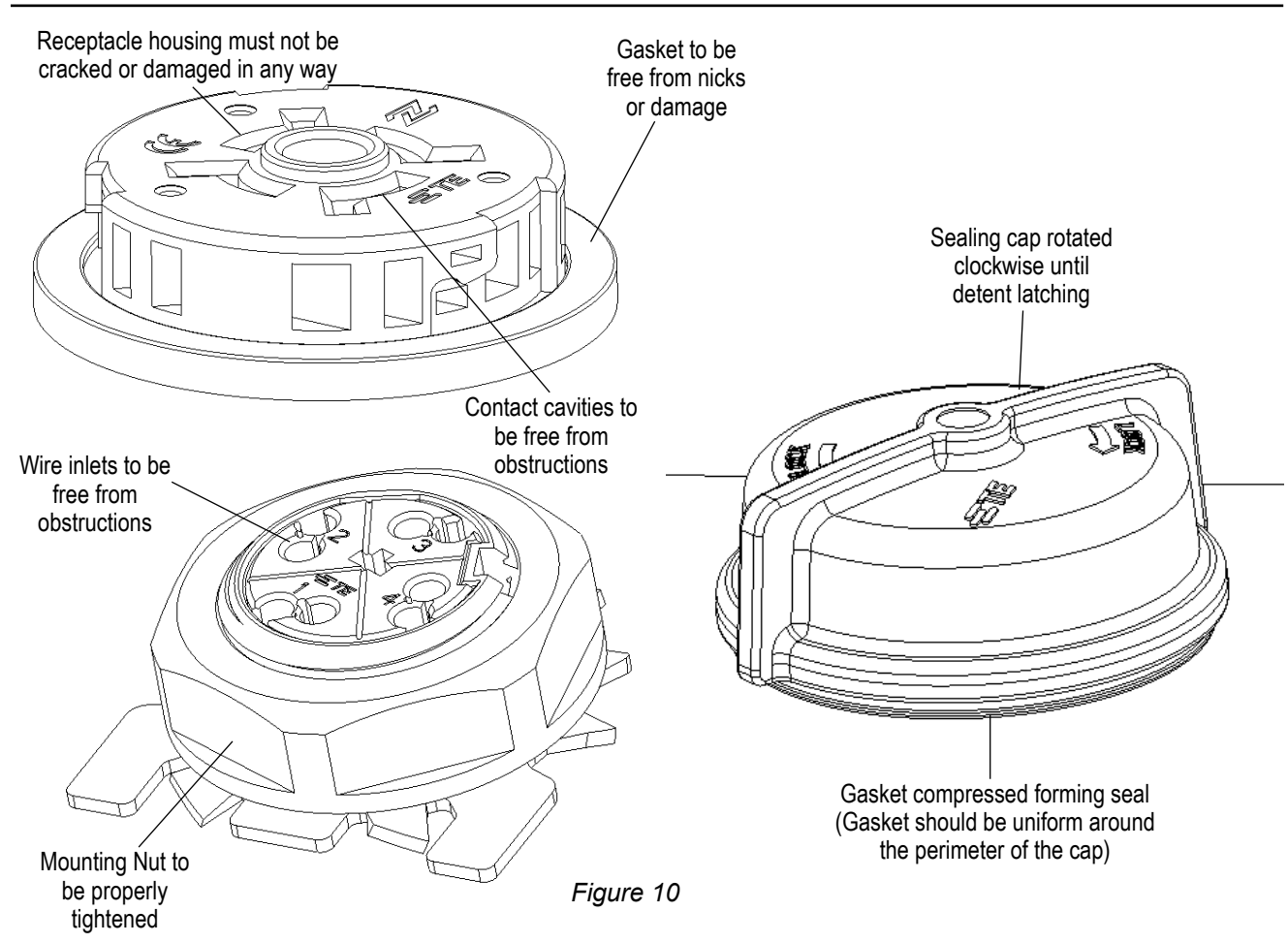

6. ADDITIONAL STANDARD VERSUS KEYED VISUAL AIDS

The additional visual aids that follow detail the differences between the standard and keyed versions. The standard version is Zhaga Book 18 compliant, while the keyed version is not. The standard version will not mate to the keyed version thus preventing mis-mating when two discrete connectors are used on the same system. The keyed receptacle has a recessed keyway that accepts the keyed module's raised key. The custom-shaped center post of the keyed module prevents mating to the standard receptacle's round hole. In turn, the custom-shaped pre-alignment hole of the keyed receptacle will not accept the round center pre-alignment post of the standard module. See Figure 11.

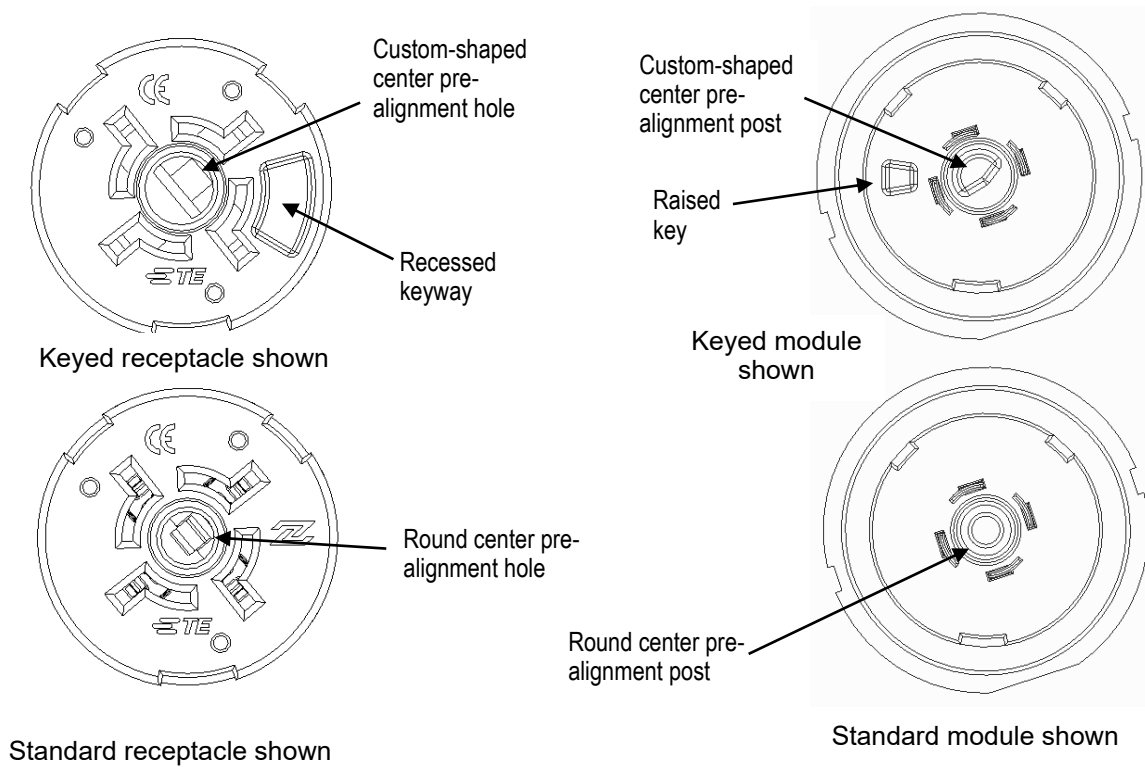

Figure 11