

This document is the property of and embodies CONFIDENTIAL and PROPRIETARY information of AORORA. No part of the information shown on this document may be used in any way or disclosed to others without the written consent of AORORA. © 2019 AORORA



REV.	ECR/ECN No.	DESCRIPTION	DRAWN/DATE	CHECKED/DATE	APPROVED/DATE
C	ECN2021069	变更图框	Abner 2021.07.08	Staven 2021.07.08	Biao 2021.07.08

NOTES:

- MATERIAL: PHOSPHOR BRONZE T=0.20mm,
- FINISH: Product welding surface electroplating GOLD FLASH, Other electroplating Ni40u"? 120 u",
- ALL MATERIAL MUST BE COMPLY WITH RoHS.

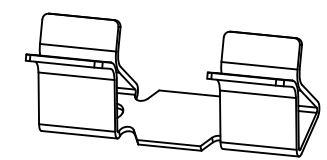
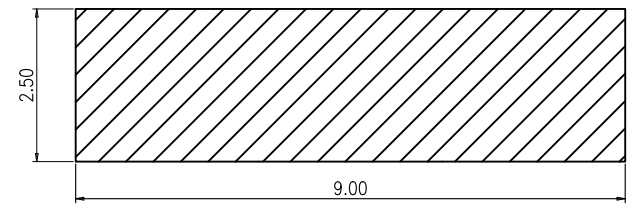
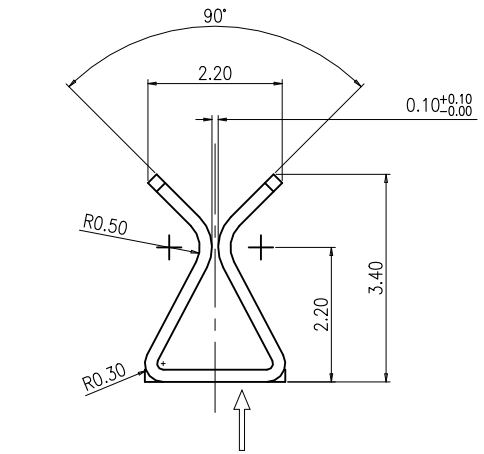
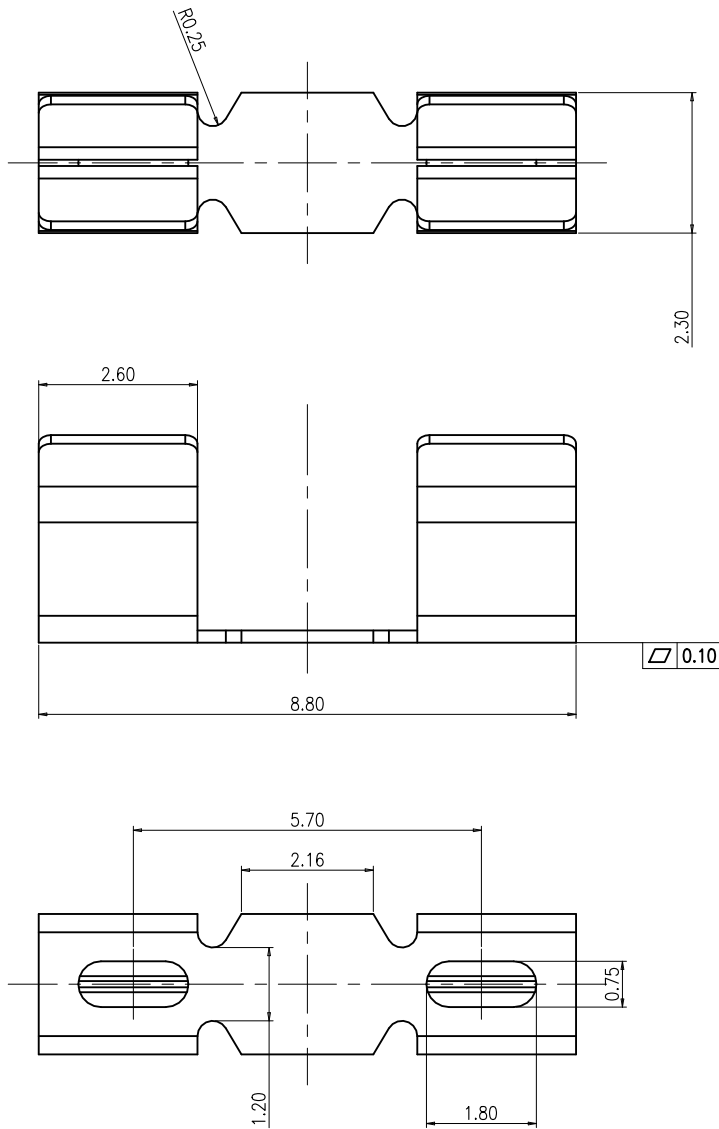

3D VIEW

文件发行
 2021.07.12
 Aorora

UNLESS OTHERWISE SPECIFIED TOLERANCES				ANGLE OF PROJECTION		Amphenol AORORA	
X.	±0.30	X. °	± 5'			Amphenol Aorora Technology (Huizhou) Co.,Ltd	
X.X	±0.20	X.X °	± 3'				
X.XX	±0.10	X.XX °	± 0.2'	Customer Drw		TITLE:	
X.XXX	±0.05	X.XXX °	± 0.1'	DRAWN	DATE	Abner	2021-07-08
LINEAR DIMS		ANGLES DIMS		DESIGN	DATE	Abner	2021-07-08
DWG NO.: A-S0288				CHECKED	DATE	Staven	2021-07-08
MATERIAL		SEE NOTES		APPROVED	DATE	Biao	2021-07-08
FINISHED		SEE NOTES		SCALE		1:1	UNIT : mm
PART NUMBER:						2002-4B7C1-11000	REV. C
SHEET						1	OF 1