

トレードマークまたはキャビティマーク  
TRADE MARK OR CAVITY MOLD NO.

**NOTE**

1. 嵌合相手 : 201644シリーズ  
MATE WITH:201644 SERIES.
2. 製品番号  
MATERIAL NO.  
201645 0\*\* \*  
極数 | 色  
CIRCUIT SIZE | COLOR
3. 偶数極に適用  
APPLY FOR CKT SIZE EQUAL EVEN.
4. 端子テール部及びネイルの平坦度は0.12MAX.とする  
TAIL AND NAIL COPLANARITY TO BE 0.12 MAX.

21.45	28.50	31.65	34.60	201645040*	40
21.45	27.00	30.15	33.10	201645038*	38
21.45	25.50	28.65	31.60	201645036*	36
17.85	24.00	27.15	30.10	201645034*	34
17.85	22.50	25.65	28.60	201645032*	32
17.85	21.00	24.15	27.10	201645030*	30
17.85	19.50	22.65	25.60	201645028*	28
12.00	18.00	21.15	24.10	201645026*	26
12.00	16.50	19.65	22.60	201645024*	24
12.00	15.00	18.15	21.10	201645022*	22
12.00	13.50	16.65	19.60	201645020*	20
8.50	12.00	15.15	18.10	201645018*	18
8.50	10.50	13.65	16.60	201645016*	16
8.50	9.00	12.15	15.10	201645014*	14
5.55	7.50	10.65	13.60	201645012*	12
5.55	6.00	9.15	12.10	201645010*	10
D	C	B	A	オーダー番号 ORDER NO.	極数 CKT NO.

部品 PART	材質 MATERIAL		
ハウジング HOUSING	ポリアミド(PA), ガラス充填, UL94V-0, 色 : 注記参照 POLYAMIDE(PA), GLASS FILLED, UL94V-0, COLOR: SEE NOTE		
ターミナル TERMINAL	黄銅 BRASS	前めっき PRE-PLATED	
	錫めっき (リフロー処理), 1.0µm以上 TIN PLATED (HEAT TREATED MATTE TIN), 1.0µm MIN.		
	ニッケルめっき (下地), 0.5µm以上 NICKEL (UNDER-PLATED), 0.5µm MIN.		
DOCUMENT STATUS	P1	RELEASE DATE	2025/07/01 07:04:08

THIS DRAWING CONTAINS INFORMATION THAT IS PROPRIETARY TO MOLEX ELECTRONIC TECHNOLOGIES, LLC AND SHOULD NOT BE USED WITHOUT WRITTEN PERMISSION

DIMENSION UNITS	SCALE	CURRENT REV DESC: REMOVED OBSOLETE PART NUMBERS AS PER PCN #515183	<b>molex</b>		
mm	2:1				
GENERAL TOLERANCES (UNLESS SPECIFIED)			SPOT-ON1.5 DUAL PLUG ASSY W/O NAIL		
ANGULAR TOL	± 3.0 °	EC NO: 826030	PRODUCT CUSTOMER DRAWING		
4 PLACES	± 0.2	DRWN: PRANAA	2025/06/25	DOCUMENT NUMBER	
3 PLACES	± 0.2	CHK'D: GGA	2025/07/01	2016450001	DOC TYPE
2 PLACES	± 0.2	APPR: GGA	2025/07/01	PSD	DOC PART
1 PLACE	± 0.2	INITIAL REVISION:		000	REVISION
0 PLACES	± 0.2	DRWN: MIKEDA01	2017/02/09	E1	
DRAFT WHERE APPLICABLE MUST REMAIN WITHIN DIMENSIONS		THIRD ANGLE PROJECTION	DRAWING	SERIES	MATERIAL NUMBER
			A3-SIZE	201645	2016450***
				CUSTOMER	SHEET NUMBER
				GENERAL	1 OF 3

NATURAL (BEIGE)

BLACK

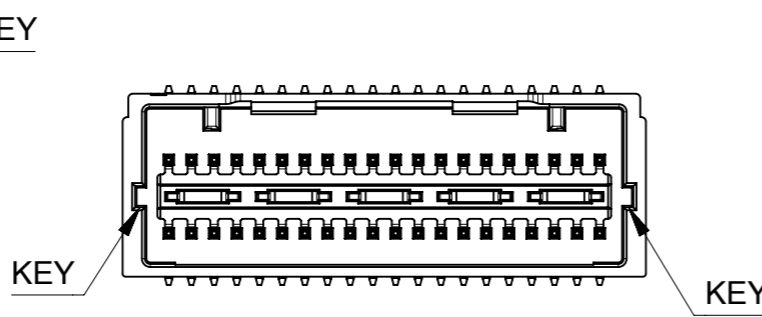
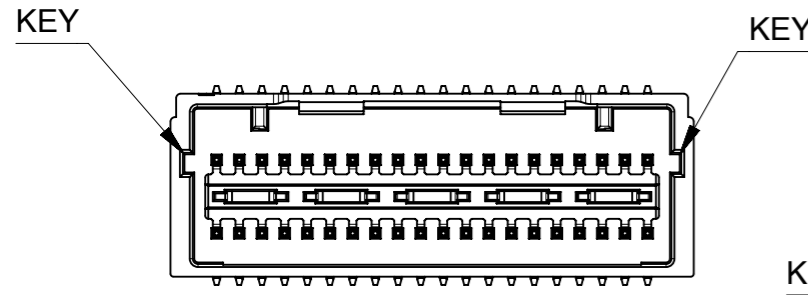

色によるキー位置違い  
COLOR VS KEY POSITION

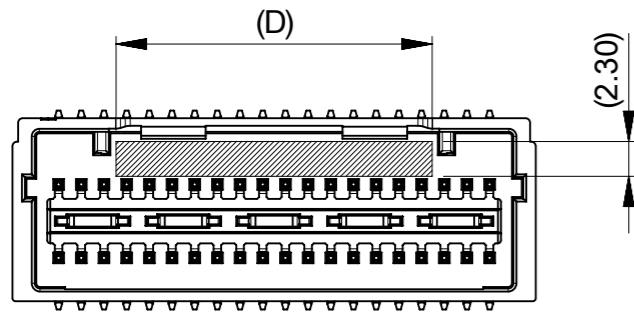
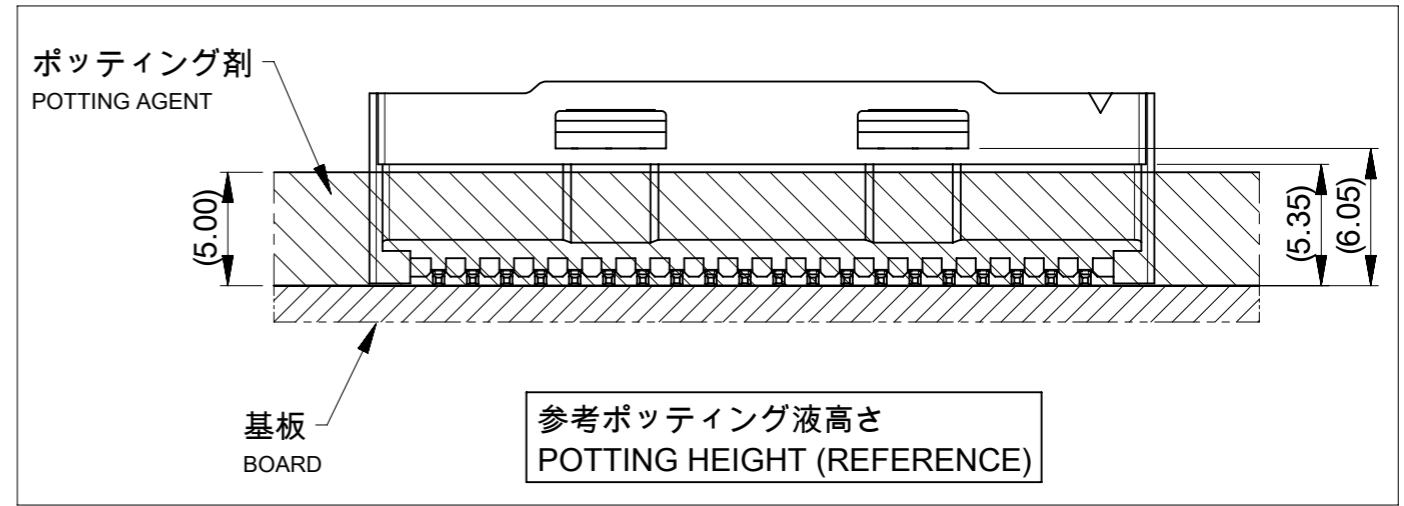

吸着範囲  
VACCUME AREA

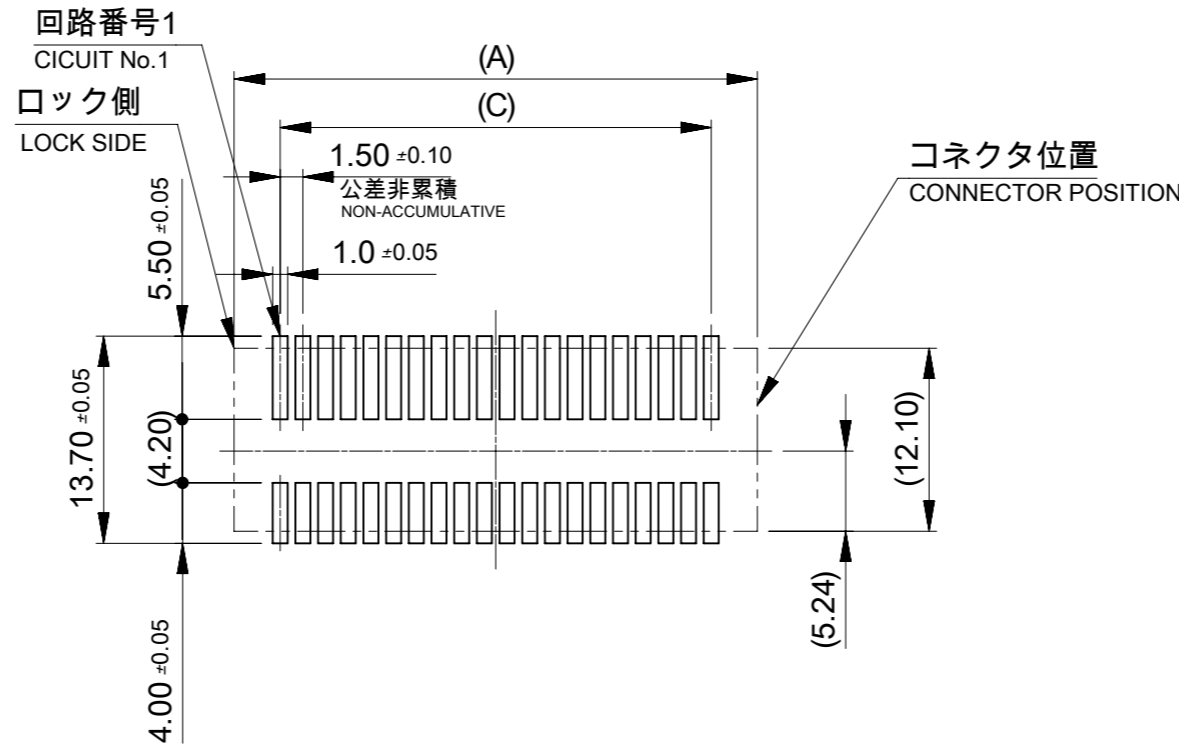

推奨基板パターンレイアウト  
RECCOMENDED PCB PATTERN LAYOUT

メタルマスク厚 : 0.15  
METAL MASK THICKNESS: 0.15  
開口率: 100%  
APARTURE RATIO: 100%

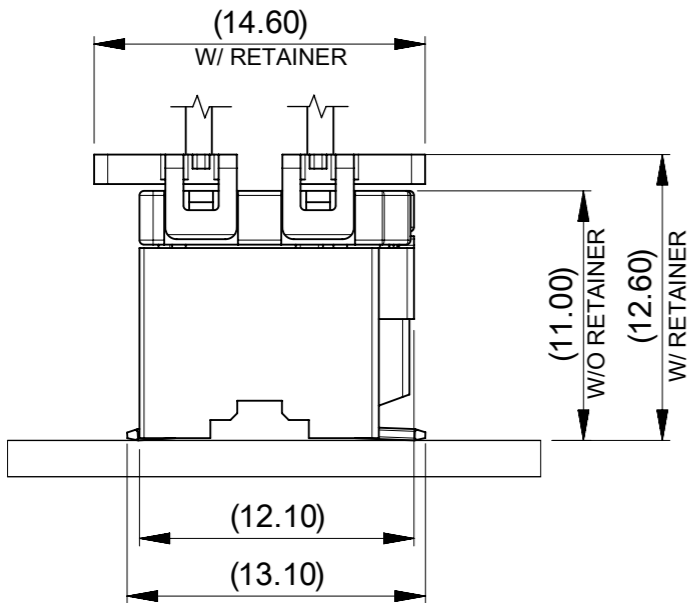

嵌合高さ  
MATING HEIGHT

BLACK	NATURAL (BEIGE)	HOUSING COLOR
2016450401	2016450400	40
2016450381	---	38
2016450361	2016450360	36
2016450341	---	34
2016450321	---	32
2016450301	2016450300	30
2016450281	---	28
2016450261	---	26
2016450241	2016450240	24
2016450221	2016450220	22
2016450201	2016450200	20
2016450181	2016450180	18
2016450161	2016450160	16
2016450141	---	14
2016450121	2016450120	12
2016450101	2016450100	10
エンボステープ梱包 EMBOSSSED TAPE PKG		極数 CKT NO.
△ 2 オーダー番号 ORDER NO.		

THIS DRAWING CONTAINS INFORMATION THAT IS PROPRIETARY TO MOLEX ELECTRONIC TECHNOLOGIES, LLC AND SHOULD NOT BE USED WITHOUT WRITTEN PERMISSION

DIMENSION UNITS <b>mm</b>	SCALE <b>2:1</b>	CURRENT REV DESC: REMOVED OBSOLETE PART NUMBERS AS PER PCN #515183	
GENERAL TOLERANCES (UNLESS SPECIFIED)		EC NO: 826030	
ANGULAR TOL	± 3.0 °	4 PLACES	± 0.2
4 PLACES	± 0.2	DRWN: PRANAA	2025/06/25
3 PLACES	± 0.2	CHK'D: GGA	2025/07/01
2 PLACES	± 0.2	APPR: GGA	2025/07/01
1 PLACE	± 0.2	INITIAL REVISION:	
0 PLACES	± 0.2	DRWN: MIKEDA01	2017/02/09
DRAFT WHERE APPLICABLE MUST REMAIN WITHIN DIMENSIONS		APPR: TKANEKO	2017/02/15
THIRD ANGLE PROJECTION	DRAWING	SERIES	MATERIAL NUMBER
	A3-SIZE	201645	2016450***
CUSTOMER		DOCUMENT NUMBER	DOC TYPE
GENERAL		2016450001	PSD
SHEET NUMBER		DOC PART	REVISION
2 OF 3		000	E1

**molex**

SPOT-ON1.5  
DUAL PLUG ASSY W/O NAIL

PRODUCT CUSTOMER DRAWING

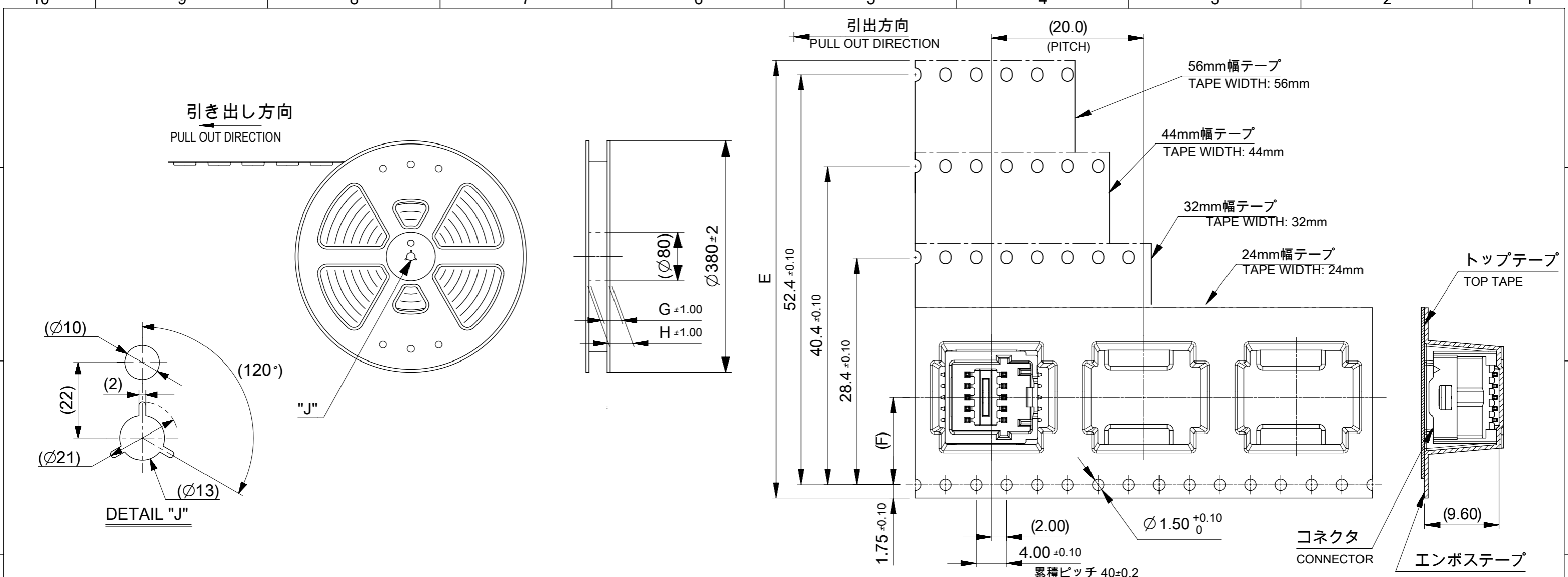

60.4	56.4	26.2	56±0.3	201645040*	40
				201645038*	38
				201645036*	36
				201645034*	34
				201645032*	32
48.4	44.4	20.2	44±0.3	201645030*	30
				201645028*	28
				201645026*	26
				201645024*	24
				201645022*	22
36.4	32.4	14.2	32±0.3	201645020*	20
				201645018*	18
				201645016*	16
				201645014*	14
28.4	24.4	11.5	24 <sup>+0.3</sup> <sub>-0.1</sub>	201645012*	12
				201645010*	10
H	G	F	E エンボステープ幅 WIDTH OF TAPE	エンボステープ梱包 EMBOSSSED TAPE PKG	極数 CKT NO.
				オーダー番号 ORDER NO.	

NOTES

- 梱包数量：450個 / リール  
NUMBER OF CONNECTORS : 450 PCS/REEL.
  - リードテープ長さ  
LEAD TAPE LENGTH.
- トップテープ未接着部 (空エンボス)  
TOP TAPE NON-BONDED PART. (EMPTY)
- 引出し方向  
PULL OUT DIRECTION
- 25±10 20-25PCS
- トップテープ接着部  
TOP TAPE BONDED PART.
- トップテープ未接着部 (空エンボス)  
TOP TAPE NON-BONDED PART. (EMPTY)
- 引き出し方向  
PULL OUT DIRECTION
- 400 MIN.
- トップテープリーダー部  
TOP TAPE LEADER PART
- 部品挿入部  
COMPONENT SUPPLIER
- 末端部 (空部)  
TAIL PART (EMPTY)  
30-35 PCS
- 材料  
キャリアテープ：ポリスチレン(PS)、その他  
トップテープ：ポリエステル(PET)、その他  
リール：ポリスチレン(PS)リサイクル材を含む  
MATERIALS  
CARRIER TAPE : POLYSTYRENE(PS), OTHER  
TOP TAPE : POLYESTER(PET), OTHER  
REEL : POLYSTYRENE(PS) RECYCLE MATERIAL CONTAINED

THIS DRAWING CONTAINS INFORMATION THAT IS PROPRIETARY TO MOLEX ELECTRONIC TECHNOLOGIES, LLC AND SHOULD NOT BE USED WITHOUT WRITTEN PERMISSION

DIMENSION UNITS mm	SCALE 2:1	CURRENT REV DESC: REMOVED OBSOLETE PART NUMBERS AS PER PCN #515183	<b>molex</b>		
GENERAL TOLERANCES (UNLESS SPECIFIED)					
ANGULAR TOL ± 3.0°	4 PLACES ± 0.2	EC NO: 826030	PRODUCT CUSTOMER DRAWING		
3 PLACES ± 0.2	DRWN: PRANAA	2025/06/25	DOCUMENT NUMBER		
2 PLACES ± 0.2	CHK'D: GGA	2025/07/01	DOC TYPE DOC PART REVISION		
1 PLACE ± 0.2	APPR: GGA	2025/07/01	2016450001 PSD 000 E1		
0 PLACES ± 0.2	INITIAL REVISION:	2017/02/09	MATERIAL NUMBER		
DRAFT WHERE APPLICABLE MUST REMAIN WITHIN DIMENSIONS	DRWN: MIKEDA01	2017/02/15	CUSTOMER		
THIRD ANGLE PROJECTION	DRAWING	SERIES	SHEET NUMBER		
A3-SIZE	201645	2016450***	3 OF 3		