

FX26 Series

140°C Heat and Vibration Resistant Board to Board Floating Connector

FunctionMAX™



Floating

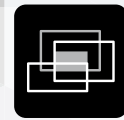

Vibration Absorb



140°C
High Temp



May. 1. 2026 Copyright 2026 HIROSE ELECTRIC CO., LTD. All Rights Reserved.



Features

1. Vibration Resistance

Design absorbs the amplitude of the boards that occur in the Z direction (connector mating direction) that occurs in a vibration environment.

2. Heat Resistance up to 140°C

The special contact enables product use underdesign high temperature environments. Additionally the two-point contact design enhances reliability.

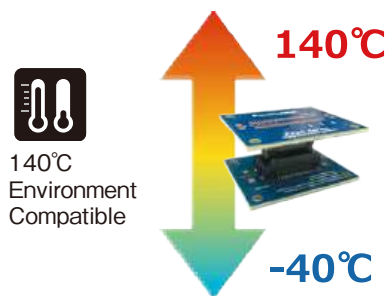

3. Board Misalignment Absorption

- X and Y Directions: $\pm 0.7\text{mm}$ Floating Range
- Z Direction: $\pm 0.75\text{mm}$ Effective Mating Length

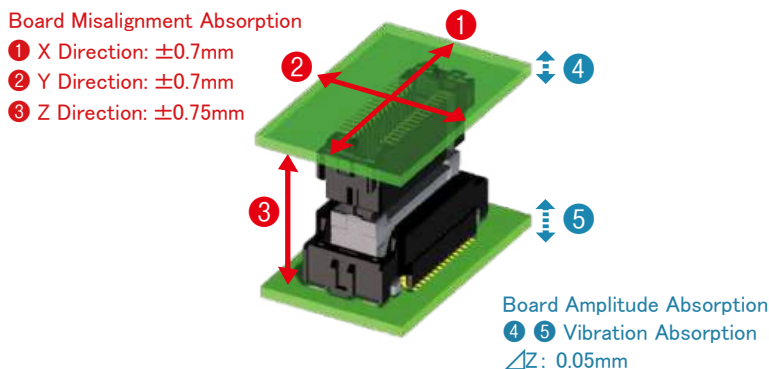

4. Contact Pitch: 1mm

5. Connection Type: Stacking

Height: 15mm/ 18mm/ 20mm/ 23mm/ 25mm

6. Pin Count Variations : 20/30/40/50/60

7. Rated Current: 0.5A/pin

8. Pick and Place Mounting

Dustproof and suction caps are installed on standard product. (Reel Packaging)

9. Excellent mating performance with large guide post

Large self-alignment range for easy mating operation.

Applications

Applicable to automotive powertrain systems (e.g., Inverter)

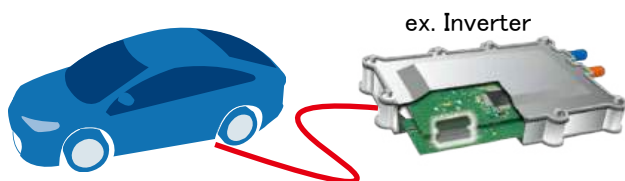

Product Specifications

Rated Current	0.5A	Operating Temperature	-40 to +140°C (Note 1)
		Storage Temperature	-10 to +60°C (Note 2)
Rated Voltage	125V AC/DC (Note 3)	Operating Humidity Range	85% Max. Relative Humidity (No dew condensation)
		Storage Humidity Range	60% Max. Relative Humidity (No dew condensation)

Item	Specifications	Conditions
Contact Resistance	65m Ω Max.	Measured at 100mA
Insulation Resistance	1000M Ω Min.	Measured at 250V DC
Withstanding Voltage	No flashover or breakdown.	375V AC for 1 min.
Mating Durability	Contact Resistance: 75m Ω Max.	10 insertion / extraction cycles.
Vibration Resistance	No electrical discontinuity of 1 μs or more.	Frequency: 50 to 100 → 100 to 150 → 150 to 300Hz Acceleration: 98 → 98 to 294 → 294m/s ² , test for 3 hours in the 3-axis direction for 1 complete cycle. (Note 4)
Shock Resistance	No electrical discontinuity of 1 μs or more.	Acceleration: 980m/s ² , Duration 6ms, sine half-wave, 3 cycles in each of the 3 axes each in both directions.
Moisture Resistance	Contact Resistance: 75m Ω Max. Insulation Resistance: 1000M Ω Min.	Left for 1000 hours at 60°C and 90 to 95% RH
Temperature Cycles	Contact Resistance: 75m Ω Max. Insulation Resistance: 1000M Ω Min.	Temperature: -40°C → +140°C Time: 30 → 30min., for 1000 cycles
Heat Resistance	Contact Resistance: 75m Ω Max.	Left at 140°C for 1000 hours

Note 1: Includes the temperature rise due to current flow.

Note 2: Storage refers to long-term storage of the unused product before mounting on board.

Note 3: The creepage distance is 32V AC when based on IEC 60664-1 Pollution degree 2.

Note 4: The board amplitude of the connector mounting portion is kept below 0.05mm.

Materials / Finish

Part	Materials	Color / Finish	Remarks
Insulator	Polyamide Resin	Black	UL94V-0
Contact	Copper Alloy	Contacted Part: Gold Plating Mounting part: Gold Plating	-
Retention Tab	Phosphor Bronze	Pure Tin Plating	-

Product Number Structure

Refer to the chart below when determining the product specifications from the product number. Please select from the product numbers listed in this catalog when placing orders.

Straight Header

FX26 - 30 P - 1 SV

① ② ③ ④ ⑤

Straight Receptacle

FX26 - 30 S - 1 SV 20

① ② ③ ④ ⑤ ⑥

① Series Name	FX26	④ Contact Pitch	1mm
② No. of Pos.	20, 30, 40, 50, 60	⑤ Product Type	SV: Straight Type
③ Connector Type	P: Header S: Receptacle	⑥ Product Height	Mated height [mm] = Numerical value on the header side + Numerical value on the receptacle side

Connection Variations Overview

		[mm]		
Receptacle Header				
	FX26-##S-1SV15	FX26-##S-1SV18	FX26-##S-1SV20	
FX26-##P-1SV				
(Note 3) 				
FX26-##P-1SV5				

Note 1: ## correspond to pin counts.

Note 2: Please contact a Hirose representative for release status.

Note 3: This type (height 23, 25mm) is a custom product. Please contact a Hirose representative for more information.

Straight Header

FX26-##P-1SV

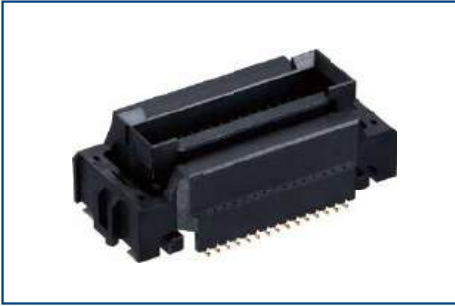

Recommended Land Pattern Diagram

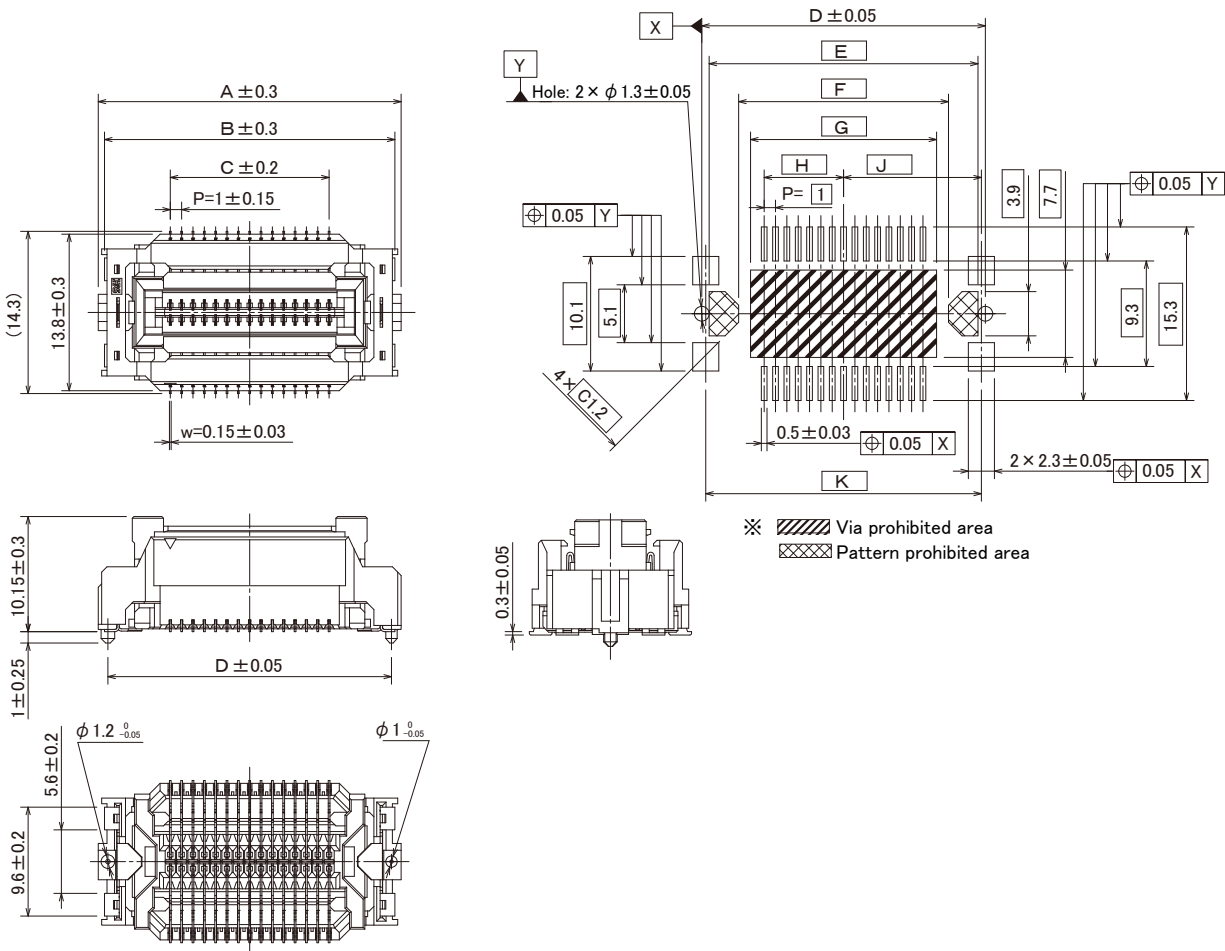

Unit : mm

Part No.	HRS No.	No. of Pos.	A	B	C	D	E	F	G	H	J	K	Purchase Unit
FX26-20P-1SV	CL0576-1002-0-00	20	21.7	20.6	9	20	18.7	13.5	11.4	4.5	9.65	19.3	250pcs per reel
FX26-30P-1SV	CL0576-1003-0-00	30	26.7	25.6	14	25	23.7	18.5	16.4	7	12.15	24.3	
FX26-40P-1SV	CL0576-1004-0-00	40	31.7	30.6	19	30	28.7	23.5	21.4	9.5	14.65	29.3	
FX26-50P-1SV	CL0576-1005-0-00	50	36.7	35.6	24	35	33.7	28.5	26.4	12	17.15	34.3	
FX26-60P-1SV	CL0576-1006-0-00	60	41.7	40.6	29	40	38.7	33.5	31.4	14.5	19.65	39.3	

FX26-##P-1SV5



Recommended Land Pattern Diagram

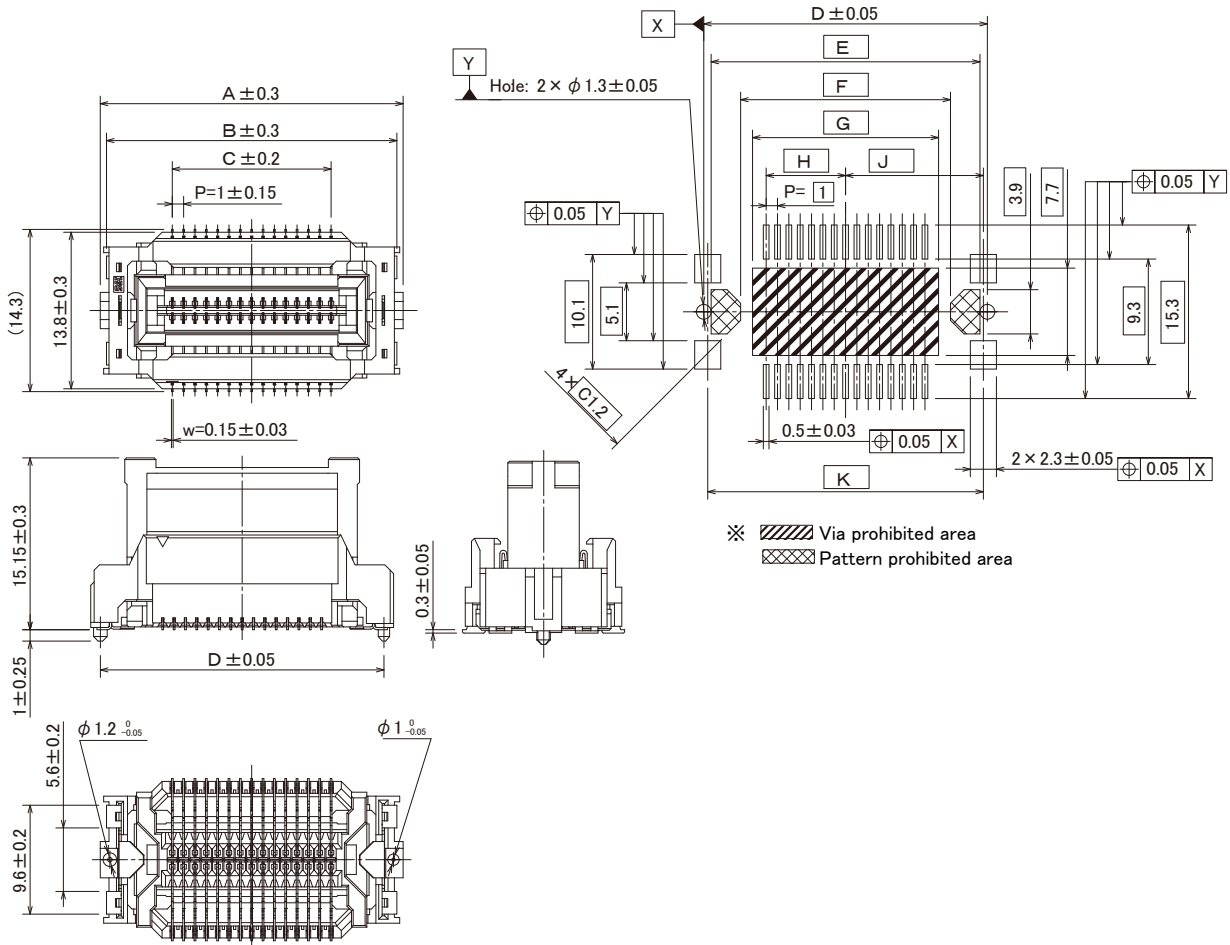

Unit : mm

Part No.	HRS No.	No. of Pos.	A	B	C	D	E	F	G	H	J	K	Purchase Unit
FX26-40P-1SV5	Upon Request (Note 1)	40	31.7	30.6	19	30	28.7	23.5	21.4	9.5	14.65	29.3	200pcs per reel
FX26-50P-1SV5	Upon Request (Note 1)	50	36.7	35.6	24	35	33.7	28.5	26.4	12	17.15	34.3	
FX26-60P-1SV5	CL0576-1506-0-00	60	41.7	40.6	29	40	38.7	33.5	31.4	14.5	19.65	39.3	

Note 1: Pin counts with the HRS No. left blank can be developed upon request. For details contact a Hirose sales representative.

Straight Receptacle

FX26-##S-1SV20



Recommended Land Pattern Diagram

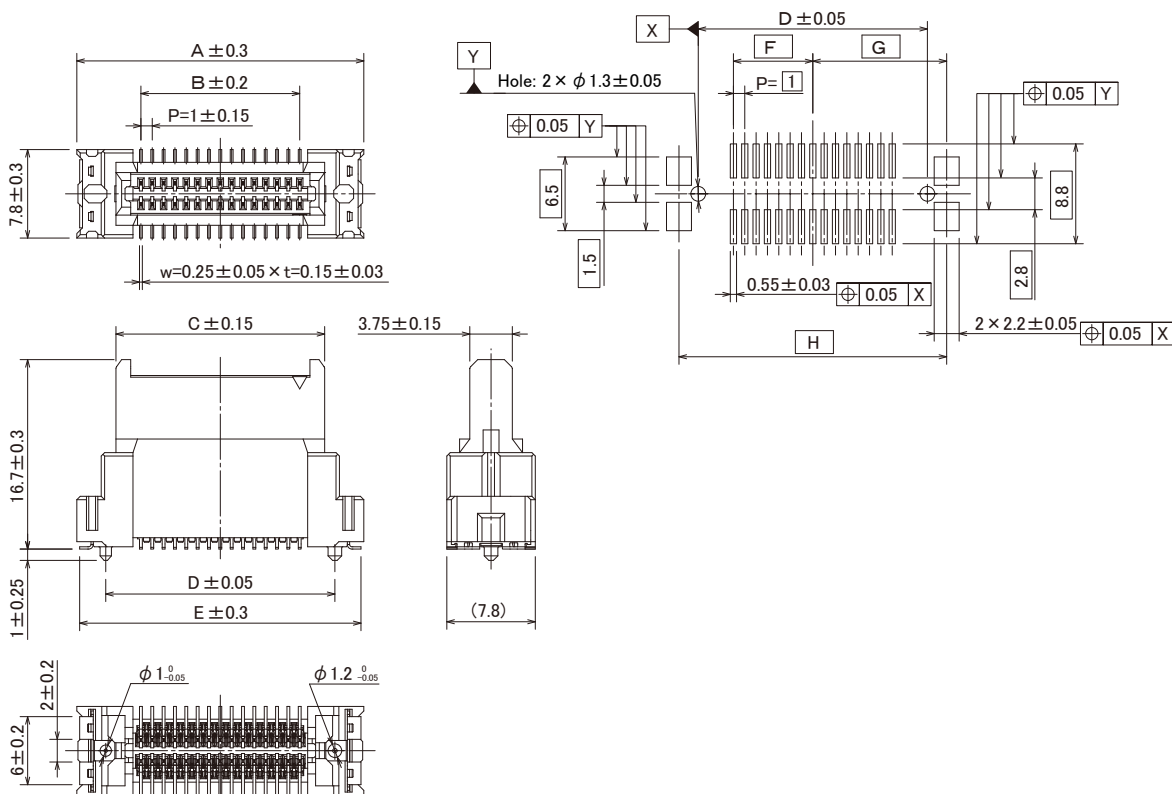

Unit : mm

Part No.	HRS No.	No. of Pos.	A	B	C	D	E	F	G	H	Purchase Unit
FX26-20S-1SV20	CL0576-1302-0-00	20	20.3	9	13.4	15.2	19.8	4.5	9.3	18.6	200pcs per reel
FX26-30S-1SV20	CL0576-1303-0-00	30	25.3	14	18.4	20.2	24.8	7	11.8	23.6	
FX26-40S-1SV20	CL0576-1304-0-00	40	30.3	19	23.4	25.2	29.8	9.5	14.3	28.6	
FX26-50S-1SV20	CL0576-1305-0-00	50	35.3	24	28.4	30.2	34.8	12	16.8	33.6	
FX26-60S-1SV20	CL0576-1306-0-00	60	40.3	29	33.4	35.2	39.8	14.5	19.3	38.6	

FX26-##S-1SV18



Recommended Land Pattern Diagram

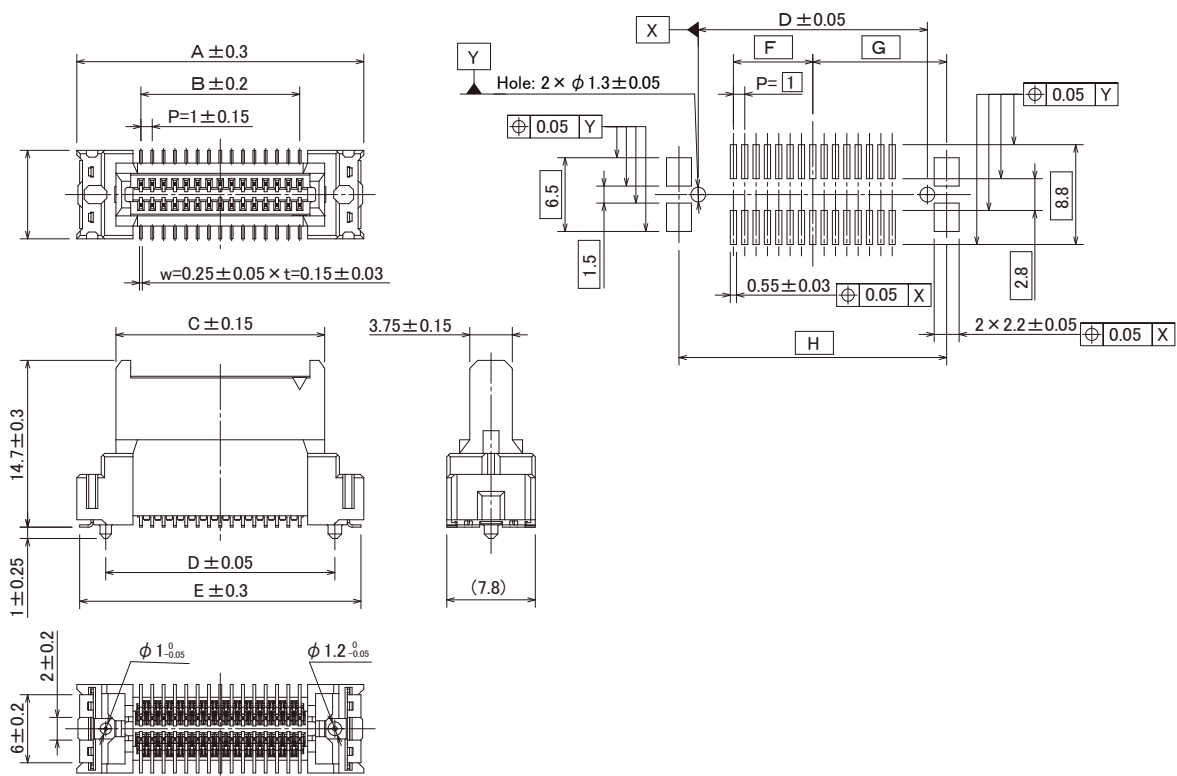

Unit : mm

Part No.	HRS No.	No. of Pos.	A	B	C	D	E	F	G	H	Purchase Unit
FX26-20S-1SV18	CL0576-1402-0-00	20	20.3	9	13.4	15.2	19.8	4.5	9.3	18.6	200pcs per reel
FX26-30S-1SV18	CL0576-1403-0-00	30	25.3	14	18.4	20.2	24.8	7	11.8	23.6	
FX26-40S-1SV18	CL0576-1404-0-00	40	30.3	19	23.4	25.2	29.8	9.5	14.3	28.6	
FX26-50S-1SV18	CL0576-1405-0-00	50	35.3	24	28.4	30.2	34.8	12	16.8	33.6	
FX26-60S-1SV18	CL0576-1406-0-00	60	40.3	29	33.4	35.2	39.8	14.5	19.3	38.6	

FX26-##S-1SV15

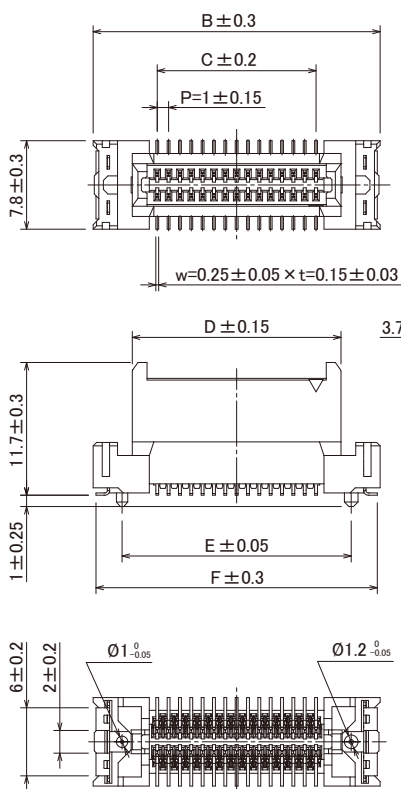

Recommended Land Pattern Diagram

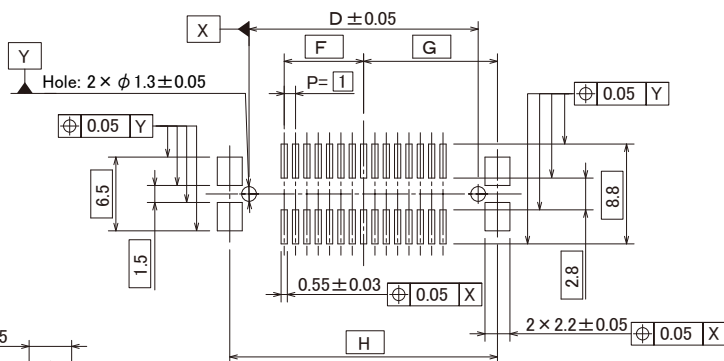

Unit : mm

Part No.	HRS No.	No. of Pos.	A	B	C	D	E	F	G	H	Purchase Unit
FX26-20S-1SV15	CL0576-1202-0-00	20	20.3	9	13.4	15.2	19.8	4.5	9.3	18.6	250pcs per reel
FX26-30S-1SV15	CL0576-1203-0-00	30	25.3	14	18.4	20.2	24.8	7	11.8	23.6	
FX26-40S-1SV15	CL0576-1204-0-00	40	30.3	19	23.4	25.2	29.8	9.5	14.3	28.6	
FX26-50S-1SV15	CL0576-1205-0-00	50	35.3	24	28.4	30.2	34.8	12	16.8	33.6	
FX26-60S-1SV15	CL0576-1206-0-00	60	40.3	29	33.4	35.2	39.8	14.5	19.3	38.6	

Embossed Packaging Diagram

Straight Header
 FX26-##P-1SV
 FX26-##P-1SV5

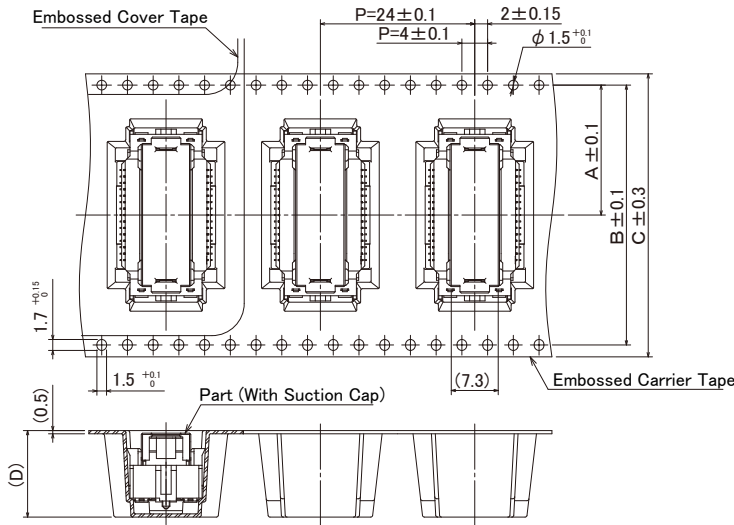

■ Reel Diagram

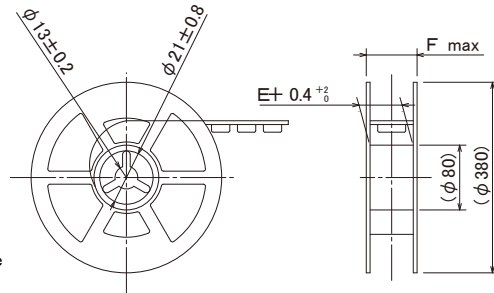

Unit : mm

Part No.	No. of Pos.	A	B	C	D	E	F	Purchase Unit
FX26-##P-1SV	20, 30	20.2	40.4	44	13.45	44.4	50.4	250 pcs per reel
	40, 50, 60	26.2	52.4	56	13.45	56.4	62.4	
FX26-##P-1SV5	40, 50, 60	26.2	52.4	56	18.45	56.4	62.4	200 pcs per reel

Straight Receptacle
 FX26-##S-1SV20
 FX26-##S-1SV18
 FX26-##S-1SV15

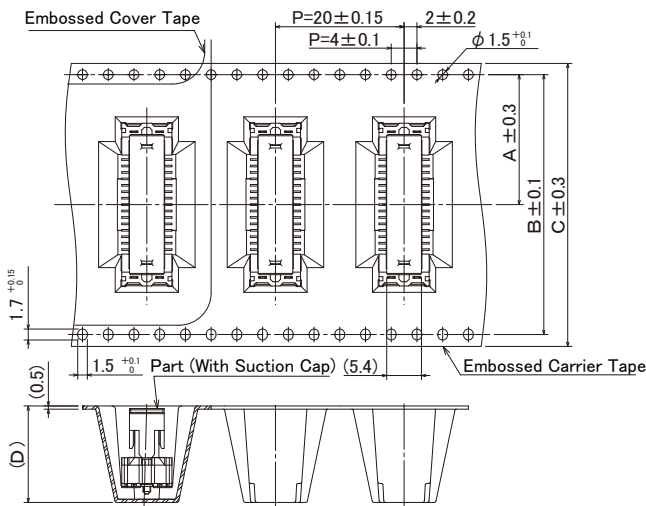

■ Reel Diagram

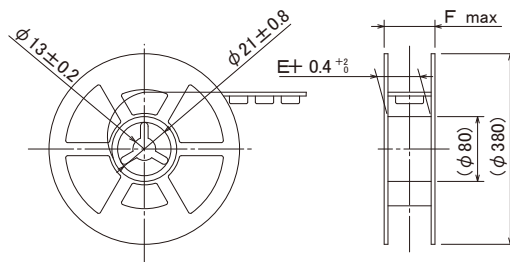

Unit : mm

Part No.	No. of Pos.	A	B	C	D	E	F	Purchase Unit
FX26-##S-1SV20	20, 30	20.2	40.4	44	20	44.4	50.4	200 pcs per reel
	40, 50, 60	26.2	52.4	56		56.4	62.4	
FX26-##S-1SV18	20, 30	20.2	40.4	44	18	44.4	50.4	200 pcs per reel
	40, 50, 60	26.2	52.4	56		56.4	62.4	
FX26-##S-1SV15	20, 30	20.2	40.4	44	15	44.4	50.4	250 pcs per reel
	40, 50, 60	26.2	52.4	56		56.4	62.4	

Recommended Temperature Profile

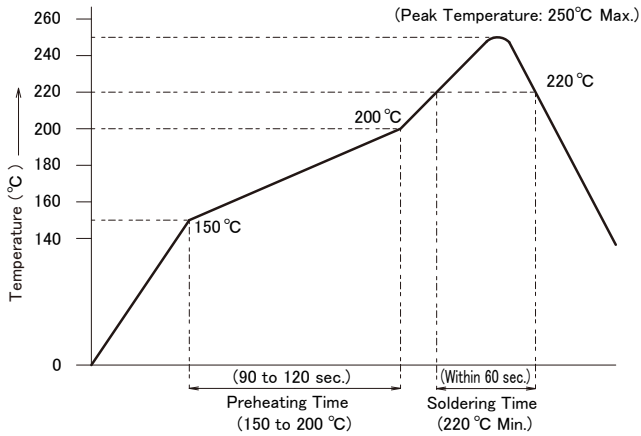

<Applicable Conditions>

Test Board Measurements: 110 × 85 × 1.6mm
 Material: Glass Epoxy
 Solder Composition: Sn-3Ag-0.5Cu
 Flux Content: 11wt%
 Metal Mask Thickness: 0.15mm
 Reflow Times: 2 times Max.

※The temperature profile is a reference under the above conditions. Temperature profile may change depending on the solder paste types, manufacturers, PCB size, and other soldering materials. Please fully check the mounting conditions before use.

Cleaning Conditions

● Cleaning with Organic Solvent

Solvent	Cleaning at room temperature	Heated Cleaning
IPA (Isopropyl Alcohol)	○	○

● Cleaning with Water

When water-type cleaning agents (terpene, alkaline saponification agents) are used, select cleaning agents based on the 'table of influence' on metals and resins issued by the cleaning agent manufacturer.

Caution: Do not leave the connector with any water content left on it.

● Cleaning Precautions

If flux or cleaning agent remains on the connector during part cleaning with organic solvent and water-based agents, it may cause deterioration of electrical performance. Confirm cleaning is performed properly.

Usage Precautions

●Securing Boards Together

If the board is supported only by the connector, an excessive load may be applied, causing damage or poor contact. Use other methods to secure the board other than connectors.

●About Board to Board Set Up Dimensions

The dimensions between PCBs shall be within the following range :

FX26-##S-1SV##

FX26-##P-1SV##

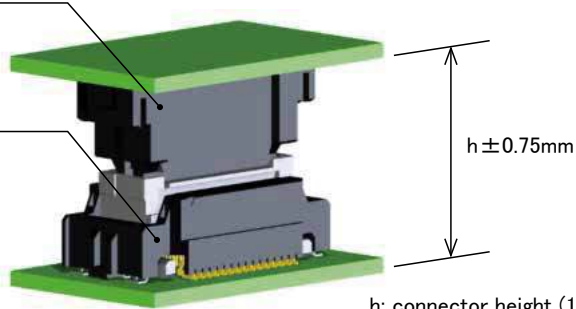

h: connector height (15, 18, 20, 23, 25)

※ The above $\pm 0.75\text{mm}$ intersection is different from board amplitude.

●Mating Operations Cautions

It is recommended to operate straight and without tilting.

·The mating self-alignment is $\pm 1.2\text{mm}$ in the X and Y directions.

Mate the connector while following the self-alignment guide and without applying excessive force.

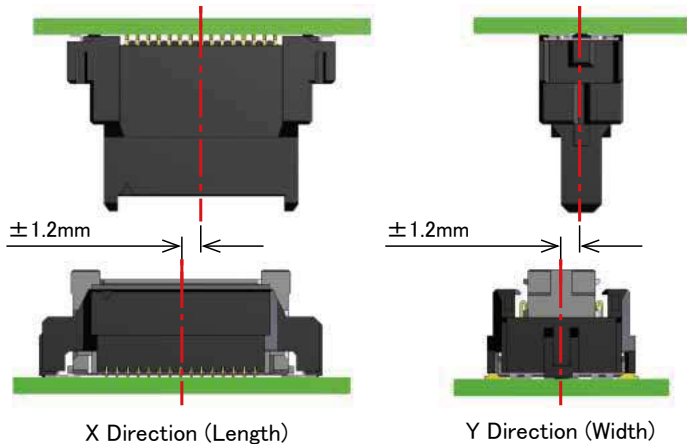

※ Rotational insertion and extraction are not recommended as it may damage the connector.

·To prevent incomplete mating or mating failure, install a backup on the back surface of the connector mounting portion during mating. Fix the board with screws after mating it securely.

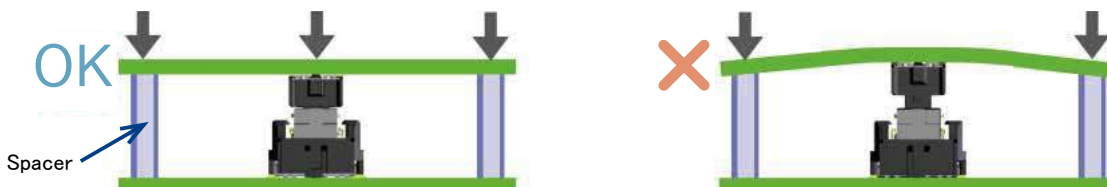

● Permissible Misalignment in the Mated State (Floating Range)

This connector is designed to float when mated, with a permissible misalignment of $\pm 0.7\text{mm}$ in both the X and Y directions.

However, it is not applicable to absorbing when the misalignment amount is continually changing due to vibration, etc. Be sure to secure PCBs after mating.

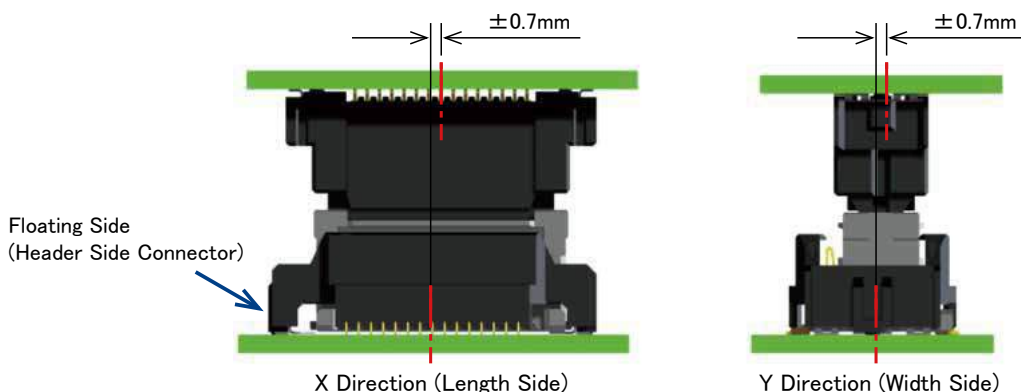

● Board Amplitude Under Vibration Conditions

This connector can absorb the board amplitude in the Z direction (connector mating direction).

However, it cannot absorb any vibration in the Z direction. The maximum absorption is 0.05mm.

Make a board design that suppresses the amplitude (Amount of change in height between substrates) of the connector mounting portion to 0.05mm or less under a vibration environment in use.

Also, design the fastening position, fastening method and case.

·Pay attention to board resonance.

·When frequency exceeds 1000Hz under constant and sweep vibrations, reduce the acceleration applied to the connector and connector mating portion to 5G or less.

While Taking into Consideration

Specifications mentioned in this catalog are reference values.

When considering to order or use this product, please review the Drawing and Product Specifications sheets.

Use an appropriate cable when using the connector in combination with cables.

If considering usage of a non-specified cable, please contact your sales representative.

If assembly process is done by jigs & tools which are not identified by Hirose, the warranty of the product may be affected.

If considering usage for below mentioned applications, please contact your sales representative.

In cases where the application will demand a high level of reliability, such as automotive, medical instruments, public infrastructure, aerospace/defense etc. Hirose must review before assurance of reliability can be given.