

THE INFORMATION CONTAINED HEREIN IS CONSIDERED "PROPRIETARY" TO BEL FUSE INC. AND SHALL NOT BE COPIED, REPRODUCED OR DISCLOSED WITHOUT THE WRITTEN APPROVAL OF BEL FUSE INC.

RoHS



ELECTRICAL CHARACTERISTICS @ 25°C

URNS RATIO

TX 1CT : 1

RX 1CT : 1

CL @ 100kHz/100mVRMS

8mA DC BIAS 350μH MIN.

INS. LOSS

1MHz TO 100MHz -1.0 dB MAX

RET. LOSS (MIN)

1MHz-30MHz -18 dB

30MHz-60MHz -18+20LOG(F/30MHz) dB

60MHz-80MHz -12 dB

CROSS TALK (TX - RX)

100kHz-100MHz -35 dB MIN

CM TO CM REJ

100kHz-100MHz -30 dB MIN

CM TO DM REJ

100kHz-100MHz -40 dB MIN

HIPOT (Isolation Voltage):

100% OF PRODUCTION TESTED TO COMPLY WITH IEEE 802.3 ISOLATION REQUIREMENTS.

LED 1

VF (FORWARD VOLTAGE) IF=20mA YELLOW 2.1V TYP.

λD (DOMINANT WAVELENGTH) IF=20mA YELLOW 590nm TYP.

LED 2

VF (FORWARD VOLTAGE) IF=20mA GREEN 2.2V TYP.

ORANGE 2.0V TYP.

λD (DOMINANT WAVELENGTH) IF=20mA GREEN 565nm TYP.

ORANGE 610nm TYP.

LED1 POLARITY			LED2 POLARITY		
PIN 7	PIN 8	COLOR	PIN 9	PIN 10	COLOR
-	+	YELLOW	+	-	ORANGE
-	+	YELLOW	-	+	GREEN

SCHEMATIC

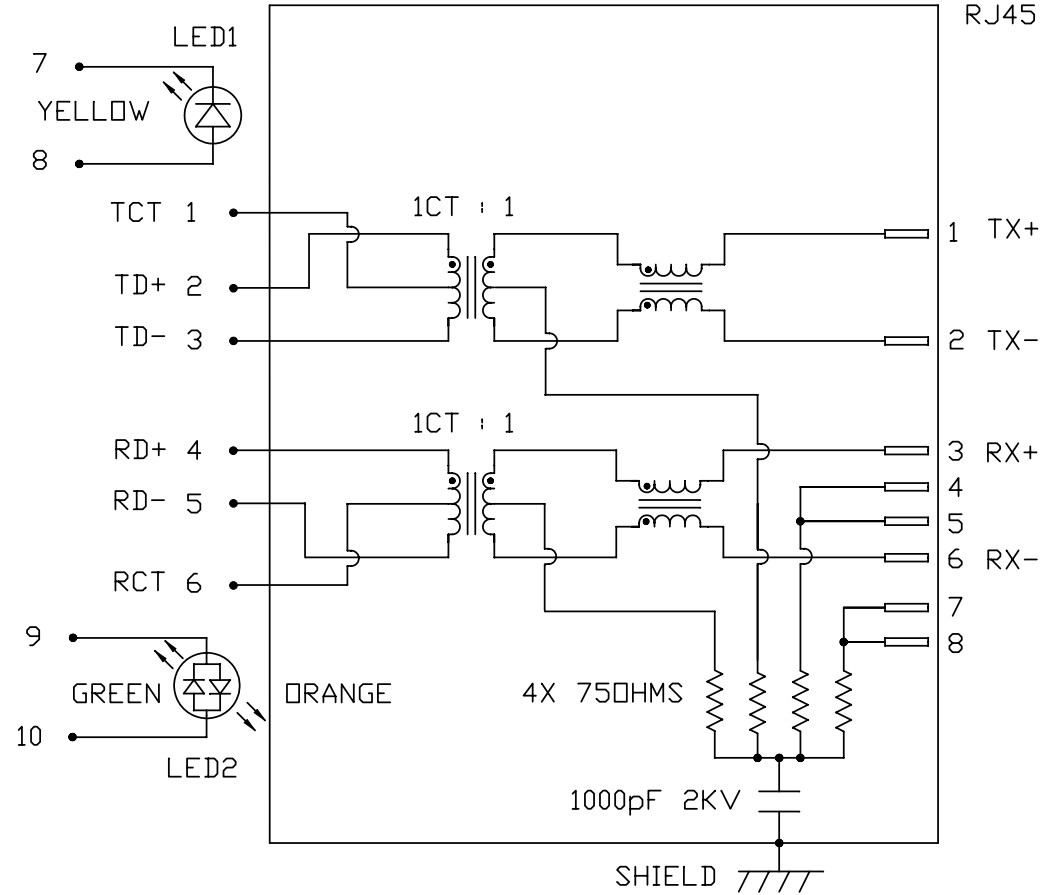

USB ELECTRICAL:

INSULATION RESISTANCE: 1000 MEG Ω (MIN)

CONTACT RESISTANCE: 25 MILLI Ω (MAX)

DIELECTRIC WITHSTANDING: 750 VAC

ORIGINATED BY	DATE	TITLE
CHOW WANCHUNG	2012-07-09	MagJack® Combo (CM Termination) PATENTED
DRAWN BY	DATE	
TAN QIGUANG	2012-07-09	

PART NO. / DRAWING NO.	08C2-1X1T-36
FILE NAME	08C2-1X1T-36_C.DWG

STANDARD DIM. TOL. IN INCH	[] METRIC DIM. AS REFERENCE
.X	UNIT : INCH [mm] REV. : C
.XX	SCALE : N/A SIZE : A4
.XXX	PAGE : 2

--	--



THE INFORMATION CONTAINED HEREIN IS CONSIDERED "PROPRIETARY" TO BEL FUSE INC. AND SHALL NOT BE COPIED, REPRODUCED OR DISCLOSED WITHOUT THE WRITTEN APPROVAL OF BEL FUSE INC.

MECHANICAL SPECIFICATION

RoHS

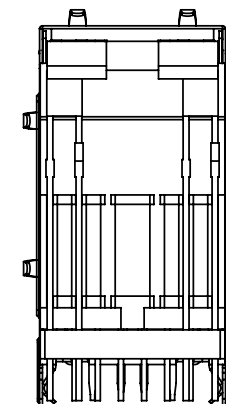
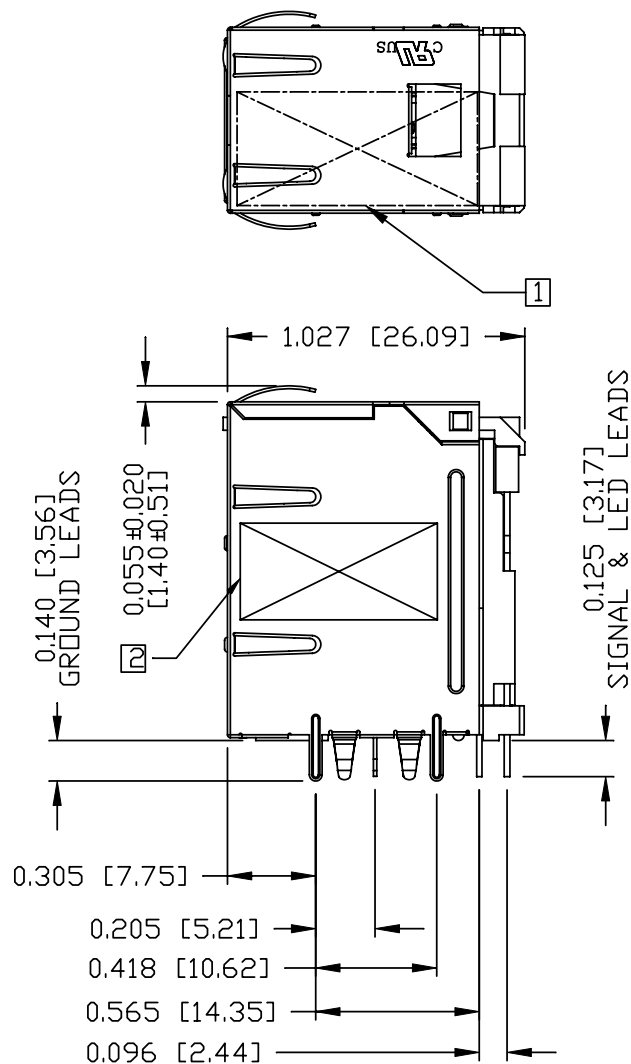
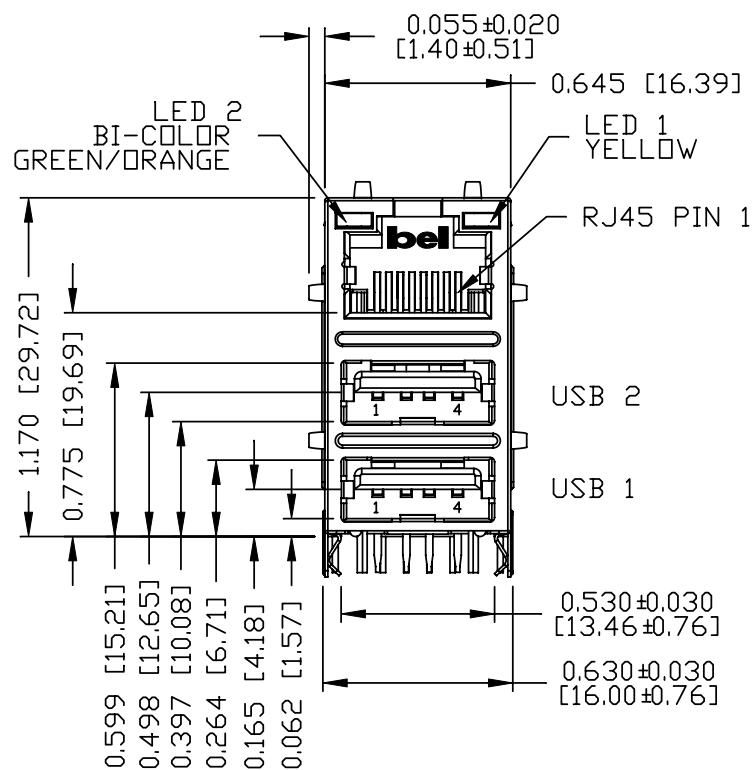

ORIGINATED BY	DATE
ANTON LIAO	2012-07-09
DRAWN BY	DATE
HE ZHEN	2012-07-09

TITLE
MagJack® Combo (CM Termination) PATENTED

PART NO. / DRAWING NO.
08C2-1X1T-36
FILE NAME
08C2-1X1T-36_C.DWG

STANDARD DIM. TOL. IN INCH
.X
.XX
.XXX

[] METRIC DIM. AS REFERENCE	REV. : C
UNIT : INCH [mm]	SIZE : A4
SCALE : N/A	PAGE : 3



THE INFORMATION CONTAINED HEREIN IS CONSIDERED "PROPRIETARY" TO BEL FUSE INC. AND SHALL NOT BE COPIED, REPRODUCED OR DISCLOSED WITHOUT THE WRITTEN APPROVAL OF BEL FUSE INC.

RoHS



Recommended PCB footprint
Component Side

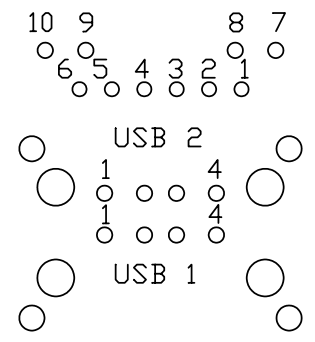
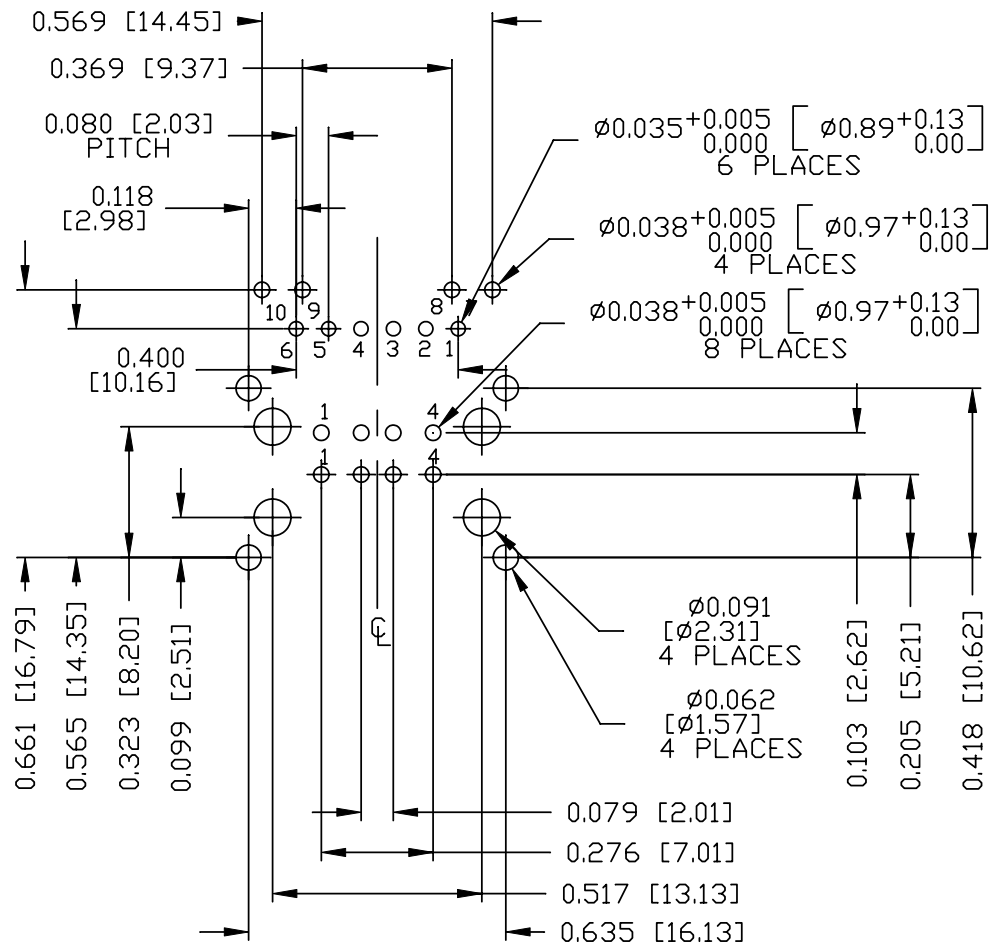

RJ45 MECHANICAL:
PLASTIC HOUSING: THERMOPLASTIC PBT OR EQUIVALENT.
CONTACT PLATING: 30 MICRO-INCH HARD GOLD PLATING OR EQUIVALENT.
PINS: TIN-COATED COPPER WIRE, DIA 0.018 INCH.
METAL SHIELD: NICKEL PLATED ON COPPER ALLOY.
(ALL GROUND LEADS ARE SOLDER DIPPED)

USB MECHANICAL:
MATING FORCE: 35 NEWTONS MAXIMUM
UNMATING FORCE: 10 NEWTONS MINIMUM
CONTACT: PHOSPHOR BRONZE
30 MICRO-INCH GOLD PLATING ON CONTACT AREA AND TIN ON SOLDER TAIL.

- RAI** USUL RECOGNIZED - FILE #E196366 AND E169987.
1. MARK PART WITH MFG LOGO, MFG NAME, PART NUMBER AND DATE CODE.
 2. "PATENTED" MARKING.
 3. THE PRODUCT IS RoHS COMPLIANT.
 4. JACK CAVITY CONFORMS TO FCC RULES AND REGULATIONS.
 5. THE PRODUCT IS PATENTED. THE PATENT NUMBER IS U.S. PAT. 5,736,910.

ORIGINATED BY ANTON LIAO	DATE 2012-07-09	TITLE MagJack® Combo (CM Termination) PATENTED	PART NO. / DRAWING NO. 08C2-1X1T-36	STANDARD DIM. TOL. IN INCH .X	[] METRIC DIM. AS REFERENCE UNIT : INCH [mm]	REV. : C	 COMPONENTS FOR A CONNECTED PLANET
DRAWN BY HE ZHEN	DATE 2012-07-09		FILE NAME 08C2-1X1T-36_C.DWG	.XX	SCALE : N/A	SIZE : A4	
			.XXX ±0.004		PAGE : 4		

THE INFORMATION CONTAINED HEREIN IS CONSIDERED "PROPRIETARY" TO BEL FUSE INC. AND SHALL NOT BE COPIED, REPRODUCED OR DISCLOSED WITHOUT THE WRITTEN APPROVAL OF BEL FUSE INC.

RoHS

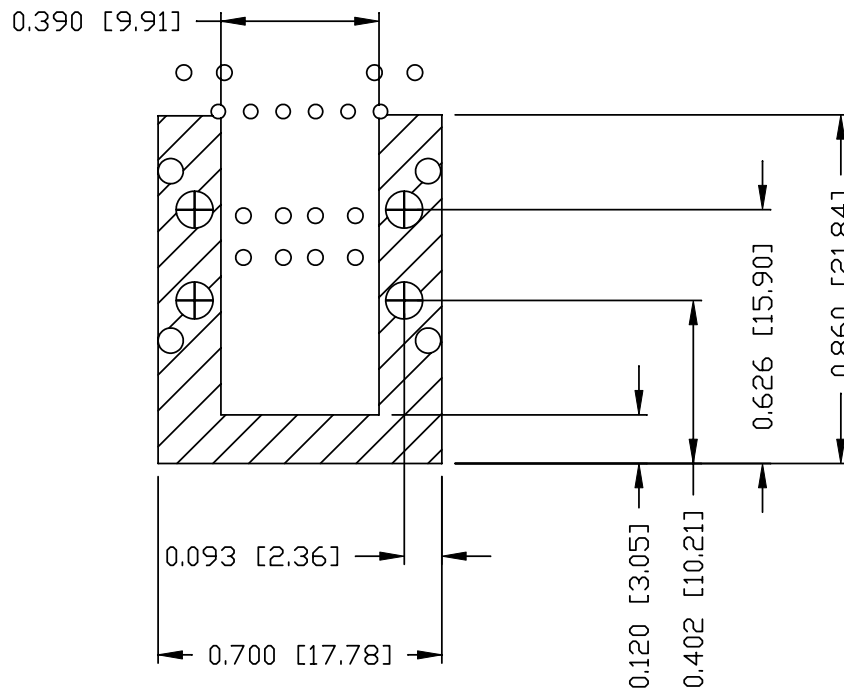

NOTES

THE SHADED AREA ON THE CUSTOMER BOARD ARE RECOMMENDED TO BE CLEAR OFF ANY VIA HOLE OR COMPONENT PAD.

ORIGINATED BY ANTON LIAO	DATE 2012-07-09	TITLE MagJack® Combo (CM Termination) PATENTED	PART NO. / DRAWING NO. 08C2-1X1T-36		STANDARD DIM. TOL. IN INCH		[] METRIC DIM. AS REFERENCE		bel COMPONENTS FOR A CONNECTED PLANET
			FILE NAME 08C2-1X1T-36_C.DWG		.X		UNIT : INCH [mm]	REV. : C	
DRAWN BY HE ZHEN	DATE 2012-07-09				.XX		SCALE : N/A	SIZE : A4	
					.XXX	±0.004		PAGE : 5	

THE INFORMATION CONTAINED HEREIN IS CONSIDERED "PROPRIETARY" TO BEL FUSE INC. AND SHALL NOT BE COPIED, REPRODUCED OR DISCLOSED WITHOUT THE WRITTEN APPROVAL OF BEL FUSE INC.

RoHS

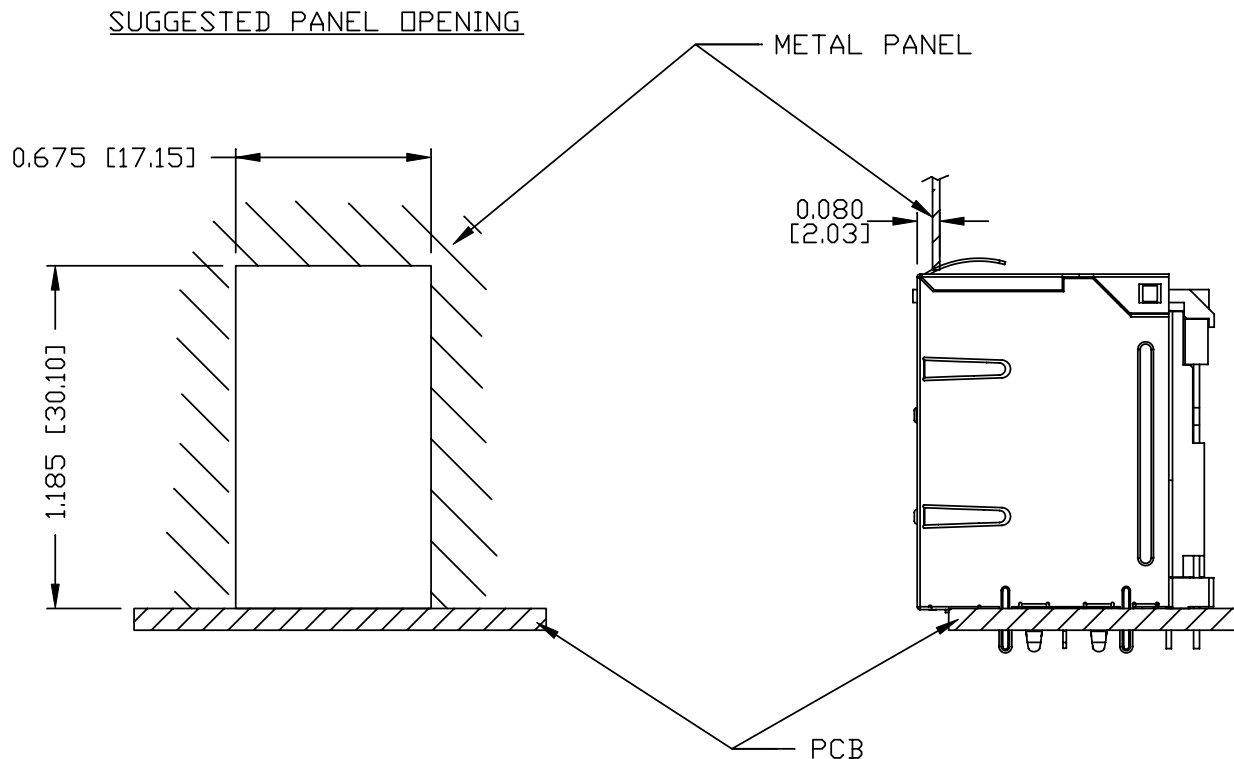
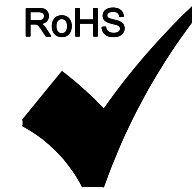

NOTE:

THE DISTANCE OF PANEL INSIDE SURFACE RELATIVE TO FRONT SURFACE OF PART IS ONLY A SUGGESTION. IN CASE THIS DISTANCE IS DIFFERENT, THE REQUIRED PANEL OPENING DIMENSIONS CHANGE ACCORDINGLY.

PACKING INFORMATION

PACKING TRAY : 0200-9999-A3

PACKING QUANTITY : 42 PCS FINISHED GOODS PER TRAY

10 TRAYS (420 PCS FINISHED GOODS) PER CARTON BOX

NOTE : CARDBOARDS ARE PLACED BETWEEN LAYERS OF PACKING TRAY INSIDE CARTON BOX (INCLUDE THE UPPERMOST AND LOWERMOST TRAY)

ORIGINATED BY ANTON LIAO	DATE 2012-07-09	TITLE MagJack® Combo (CM Termination) PATENTED	PART NO. / DRAWING NO. 08C2-1X1T-36	STANDARD DIM. TOL. IN INCH		[] METRIC DIM. AS REFERENCE		REV. : C	bel COMPONENTS FOR A CONNECTED PLANET
	DRAWN BY HE ZHEN			DATE 2012-07-09	FILE NAME 08C2-1X1T-36_C.DWG	.X .XX .XXX	UNIT : INCH [mm] SCALE : N/A ±0.004		