

PRODUCT NUMBER  
SEE TABLE

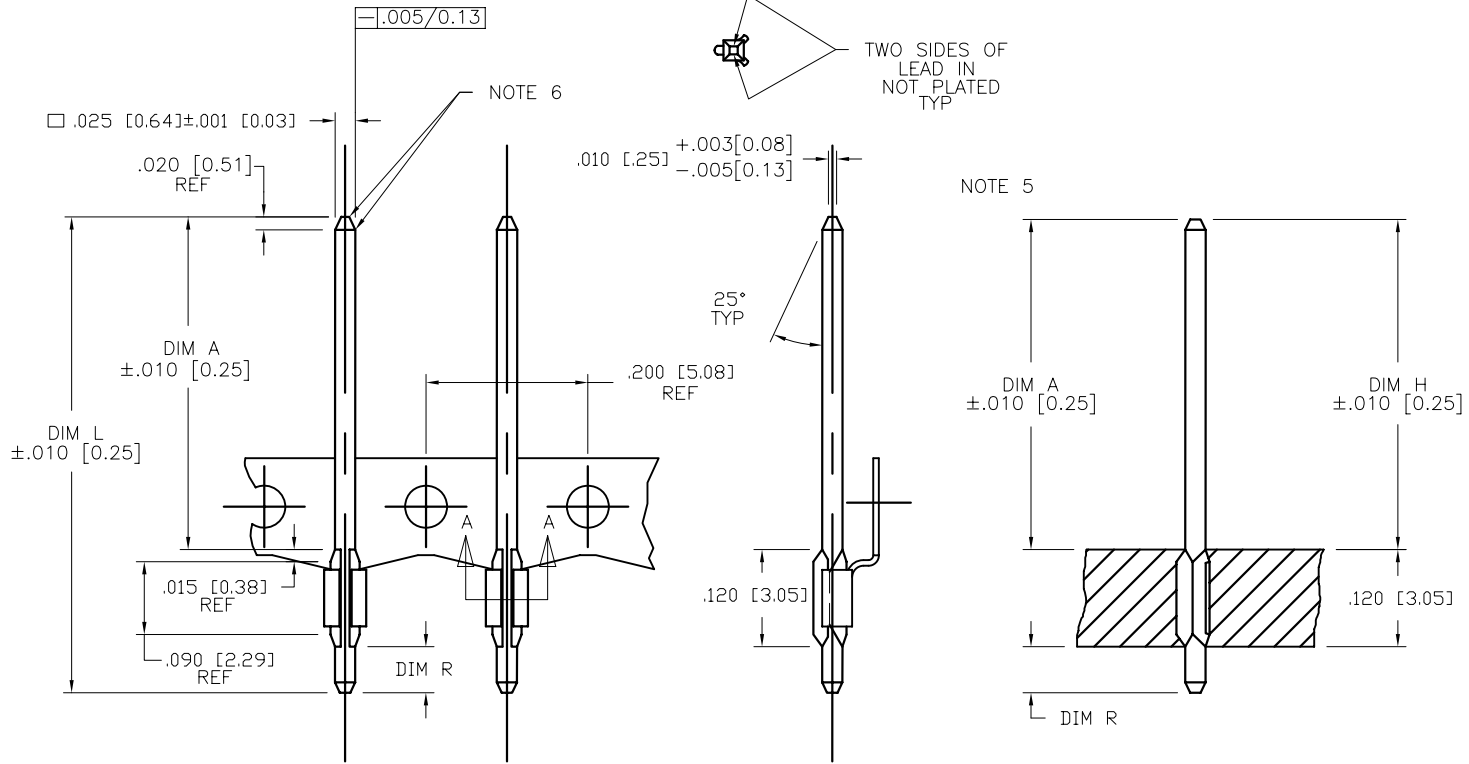

SECTION THRU P.C. BOARD

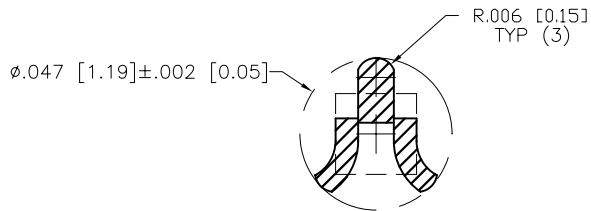

SECTION A-A  
SCALE 4:1  
WITHOUT FERRULE

mat'l. code		surface		tolerance		projection		product family	
SEE NOTE 1		ASME Y14.5		ASME Y14.5		INCH/MM		PIN PRODUCTS	
ltr	ec'n no	dr	date	angles	fin	fin	INCH/MM	title	
W	V08-0376	HTB	2008-08-27		XX*01/X*3			TRI-PIN™	
-	-	-	-		XXX*005/XXX*13			.200" [5.08]cc	
R	V90053	SAR	1999-01-25	0°±2'	XXXX*0020/XXX*051		scale 5:1	dwg no	
S	V01594	JRW	2000-07-12	dr	E. KROPIEWNICKI			sheet 1 of 3	
T	V05-0400	HTB	2005-04-28	enfr	L. FYE			size	
U	V06-0684	HTB	2006-07-24	chr	T. BREWBAKER			75491	
V	V07-0009	HTB	2007-01-05	appd	L. FYE			A4	
sheet		revision	w	w	w			type	
index	sheet	1	2	3				CUSTOMER Drawing	

PRODUCT NUMBER NOTE 8	PLATING	UNDERPLATING
75491-YYY	30μ" [0.76μ] MIN Au	50μ" [1.27μ] MIN Ni
75491-YYLFF		
75493-YYY	50μ" [1.27μ] MIN Au	50μ" [1.27μ] MIN Ni
75493-YYLFF		
75494-YYY	120μ" [3.05μ] MIN 93/7 SnPb	50μ" [1.27μ] MIN Ni
75494-YYLFF	100μ" [2.54μ] MIN Sn (NOTE 9)	50μ" [1.27μ] MIN Ni
75495-YYY	30μ" [0.76μ] MIN GXT™	50μ" [1.27μ] MIN Ni
75495-YYLFF		
75496-YYY	15μ" [0.38μ] MIN GXT™	50μ" [1.27μ] MIN Ni
75496-YYLFF		
75499-YYY	15μ" [0.38μ] MIN Au	50μ" [1.27μ] MIN Ni
75499-YYLFF		

DISCONTINUED

NOTES:

- ① PIN MATERIAL: PHOS BRONZE 3/4 HARD  
ASTM-B-159-66
2. SEE PRODUCT SPECIFICATION BUS-12-069 FOR P.C. BOARD HOLE DIAMETER AND P.C. BOARD HOLE PLATING INFORMATION.
3. .002 [0.05] R MAX TYP 4X ON WIRE WRAP PORTION OF PIN.
- ④ TRI-PINS ARE NOT RECOMMENDED FOR USE IN .062 [1.57] OR .093 [2.36] BOARDS.
- ⑤ .016 [0.41] MAX OPPOSITE END IF R DIM IS LESS THAN .230 [5.84].
- ⑥ BURNISH MARKS ON PIN PERMITTED, BURR .003 [0.08] MAX BULGE .0005 [0.013] TYP.
7. USE FIRST TWO DIGITS OF "H" DIMENSIONS FOR DASH NUMBER OF PUNCH FROM MACHINE EPL:  
EXAMPLE:  
P/N 75491-001 PUNCH P/N FROM EPL  
"H" FOR .120 [3.05] BD=.600 BP161A-XXXXXX-060  
BP151-YYYYYY-060  
BP171-ZZZZZZ-060
- ⑧ ADD AN LF SUFFIX TO PART NUMBERS FOR PRODUCT THAT MEETS EUROPEAN UNION DIRECTIVES AND OTHER COUNTRY REGULATIONS AS DESCRIBED IN GS-22-008.
- ⑨ THIS PRODUCT HAS 100% TIN PLATING IN THE INTERFACE AND HAS NOT BEEN TESTED FOR WHISKER GROWTH IN ALL INTERCONNECT ENVIRONMENTS.

mat'l. code SEE NOTE 1		surface ASME Y14.5	tolerance ASME Y14.5	projection 	product family PIN PRODUCTS
ltr	ecn no	dr	date	title	
w				TRI-PIN™ .200" [5.08]cc	
			angles	INCH/MM	scale 1:1
			0°±2'		
		dr	T. BREWBAKER	1996-05-21	dwg no
		enrg	L. FYE	1996-05-21	sheet 2 of 3
		chr	T. BREWBAKER	1996-05-21	75491
		appd	L. FYE	1996-05-21	A4
sheet	revision				type
index	sheet				CUSTOMER Drawing



PRODUCT NUMBER	CONTACT AREA		DIM H FOR .120/3.05 BOARD		DIM H FOR .093/2.36 BOARD NOTE 4		DIM H FOR .062/1.57 BOARD NOTE 4		OVERALL LENGTH		TERM. AREA	
	DIM A	DIM A	ENGLISH	METRIC	ENGLISH	METRIC	ENGLISH	METRIC	DIM L	DIM L	DIM R	DIM R
NOTE 8	ENGLISH	METRIC	ENGLISH	METRIC	ENGLISH	METRIC	ENGLISH	METRIC	ENGLISH	METRIC	ENGLISH	METRIC
7549X-001	0.600	15.24	0.600	15.24	0.615	15.62	0.630	16.00	0.770	19.56	0.050	1.27
7549X-002	0.490	12.45	0.490	12.45	0.505	12.83	0.520	13.21	0.660	16.76	0.050	1.27
7549X-003	0.600	15.24	0.600	15.24	0.615	15.62	0.630	16.00	1.050	26.67	0.330	8.38
7549X-004	0.260	6.60	0.260	6.60	0.275	6.99	0.290	7.37	0.430	10.92	0.050	1.27
7549X-005	0.280	7.11	0.280	7.11	0.295	7.49	0.310	7.87	0.730	18.54	0.330	8.38
7549X-006	0.730	18.54	0.730	18.54	0.745	18.92	0.760	19.30	0.900	22.86	0.050	1.27
7549X-007	0.370	9.40	0.370	9.40	0.385	9.78	0.400	10.16	0.540	13.72	0.050	1.27
7549X-008	0.690	17.53	0.690	17.53	0.705	17.91	0.720	18.29	0.850	21.59	0.040	1.02
7549X-009	0.205	5.21	0.205	5.21	0.220	5.59	0.235	5.97	0.375	9.53	0.050	1.27
7549X-010	0.390	9.91	0.390	9.91	0.405	10.29	0.420	10.67	0.560	14.22	0.050	1.27
7549X-011	0.545	13.84	0.545	13.84	0.560	14.22	0.575	14.61	0.715	18.16	0.050	1.27
7549X-012	0.610	15.49	0.610	15.49	0.625	15.88	0.640	16.26	0.780	19.81	0.050	1.27
7549X-013	0.320	8.13	0.320	8.13	0.335	8.51	0.350	8.89	0.660	16.76	0.215	5.46
7549X-014	0.315	8.00	0.315	8.00	0.330	8.38	0.345	8.76	0.485	12.32	0.050	1.27
7549X-015	0.345	8.76	0.345	8.76	0.360	9.14	0.375	9.53	0.775	19.69	0.310	7.87
7549X-016	0.425	10.80	0.425	10.80	0.440	11.18	0.455	11.56	0.855	21.72	0.310	7.87
7549X-017	0.220	5.59	0.220	5.59	0.235	5.97	0.250	6.35	0.420	10.67	0.080	2.03
7549X-018	0.425	10.80	0.425	10.80	0.440	11.18	0.455	11.56	0.625	15.88	0.080	2.03
7549X-019	0.415	10.54	0.415	10.54	0.430	10.92	0.445	11.30	0.575	14.61	0.040	1.02
7549X-020	0.220	5.59	0.220	5.59	0.235	5.97	0.250	6.35	0.395	10.03	0.055	1.40
7549X-021	0.425	10.80	0.425	10.80	0.440	11.18	0.455	11.56	0.600	15.24	0.055	1.40
7549X-022	0.360	9.14	0.360	9.14	0.375	9.53	0.390	9.91	0.905	22.99	0.425	10.80

mat'l. code		surface		tolerance		projection		product family	
SEE NOTE 1		ASME Y14.5		ASME Y14.5				PIN PRODUCTS	
ltr	ecn no	dr	date	tolerances unless otherwise specified		INCH/MM		title	
w				angles	XX*01/XX*3			TRI-PIN™	
					XXX*005/XX*13			.200" [5.08]cc	
					XXXX*0020/XXX*051	scale 1:1		dwg no	
		dr	T. BREWBAKER	1996-05-21				sheet 3 of 3 size	
		engr	L. FYE	1996-05-21				75491 A4	
		chr	T. BREWBAKER	1996-05-21				type	
		appd	L. FYE	1996-05-21				CUSTOMER Drawing	
sheet index	revision sheet								