

MHF[®] 7S

Excellent EMI performance with fully-shielded design, ideal for 5G mmWave applications, VSWR 1.5 max at 15 GHz in small 2.0 x 2.0 mm footprint

Product Specifications:

Mated Height	1.4 mm max.	
Rece. SMT Size	2.0 x 2.0 mm	
Applicable Frequency	DC ~ 15 GHz	
Characteristic Impedance	50 ohm	
VSWR (L = 100 mm)	DC ~ 3 GHz	1.30 max.
	3 ~ 6 GHz	1.35 max.
	6 ~ 9 GHz	1.40 max.
	9 ~ 12 GHz	1.45 max.
	12 ~ 15 GHz	1.50 max.

Applicable Cable Size:

O.D. 1.13 mm/AWG 32

Applicable Standards (Reference Only):

5G mmWave (~ 15 GHz), 5G sub-6, Wi-Fi 6E, WiGig, LTE/LTE-Advanced, LPWA, Bluetooth, GPS



► **Unique shielded design (ZenShield[®]) reduces unwanted EMI found in 5G mmWave applications**

Electric field strength distribution (simulation)

MHF[®] 4L
General design

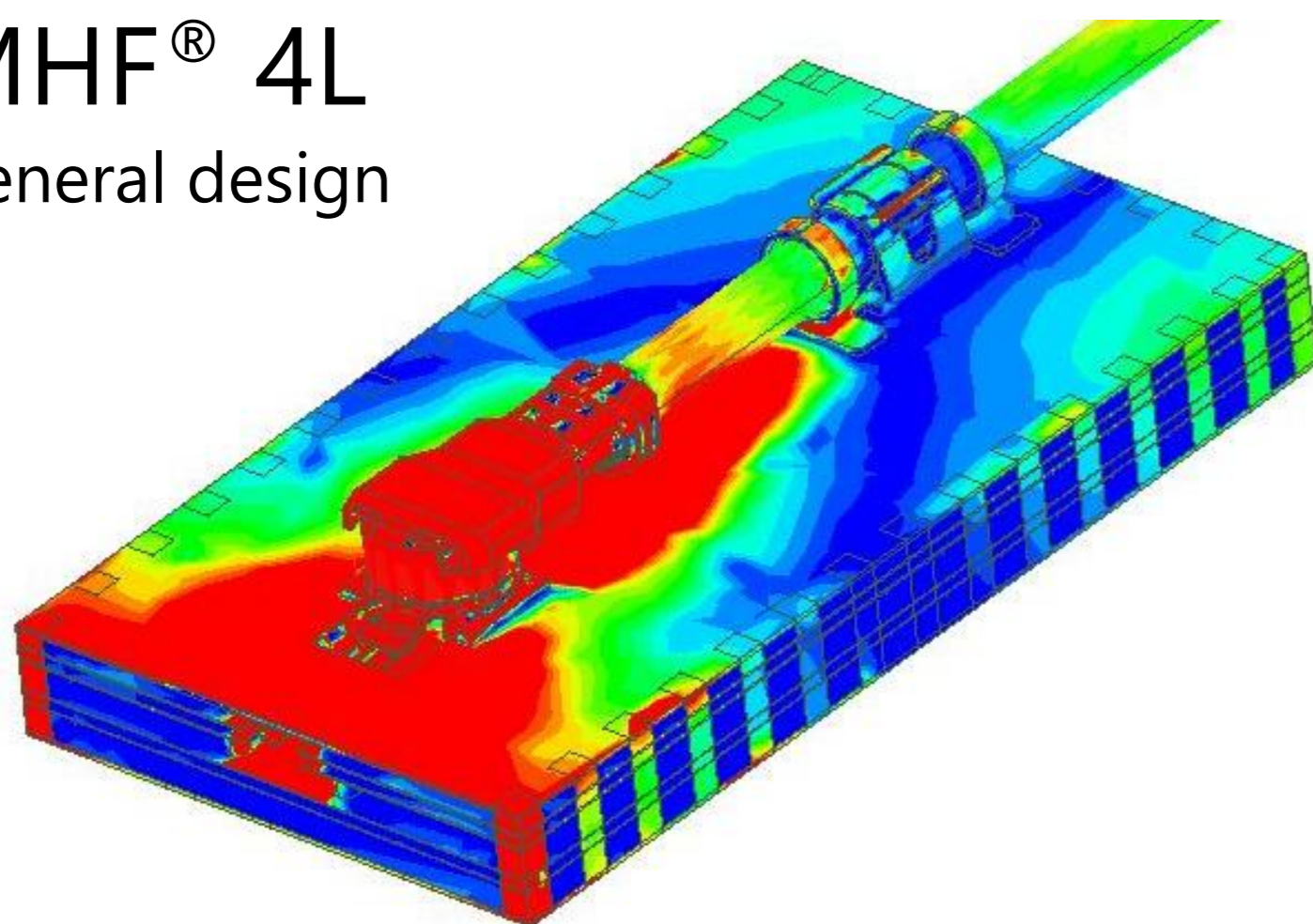

MHF[®] 7S

High-performance
EMI shielding design

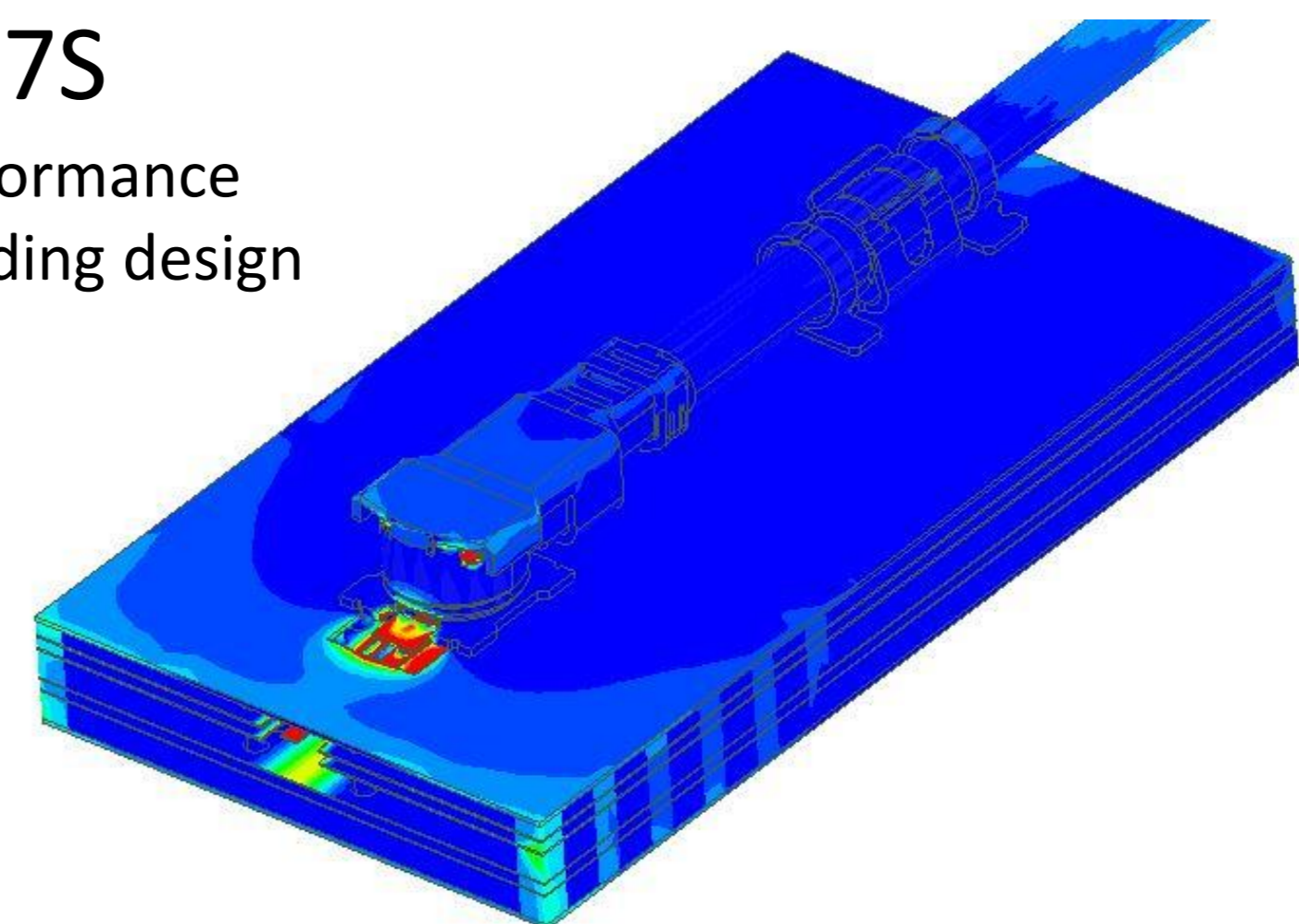

► **Small form factor with max VSWR 1.50**

Harness & Rece mating condition
Harness length : 100 mm

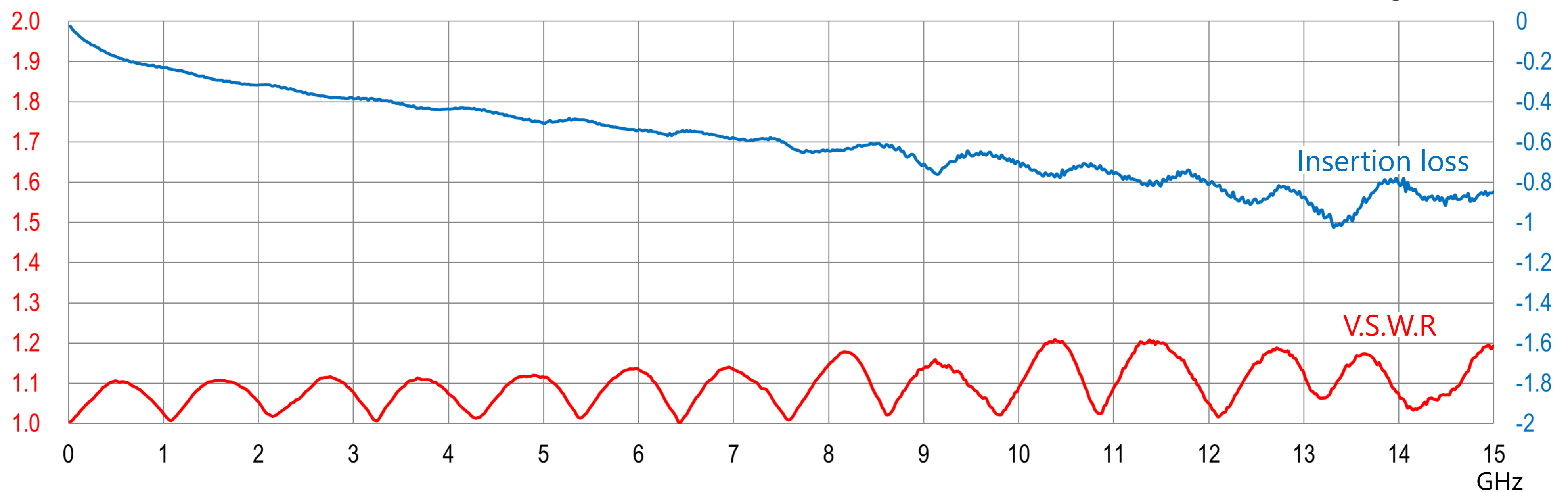

► **Industry-first stripline terminated signal pin inside receptacle ground contact**

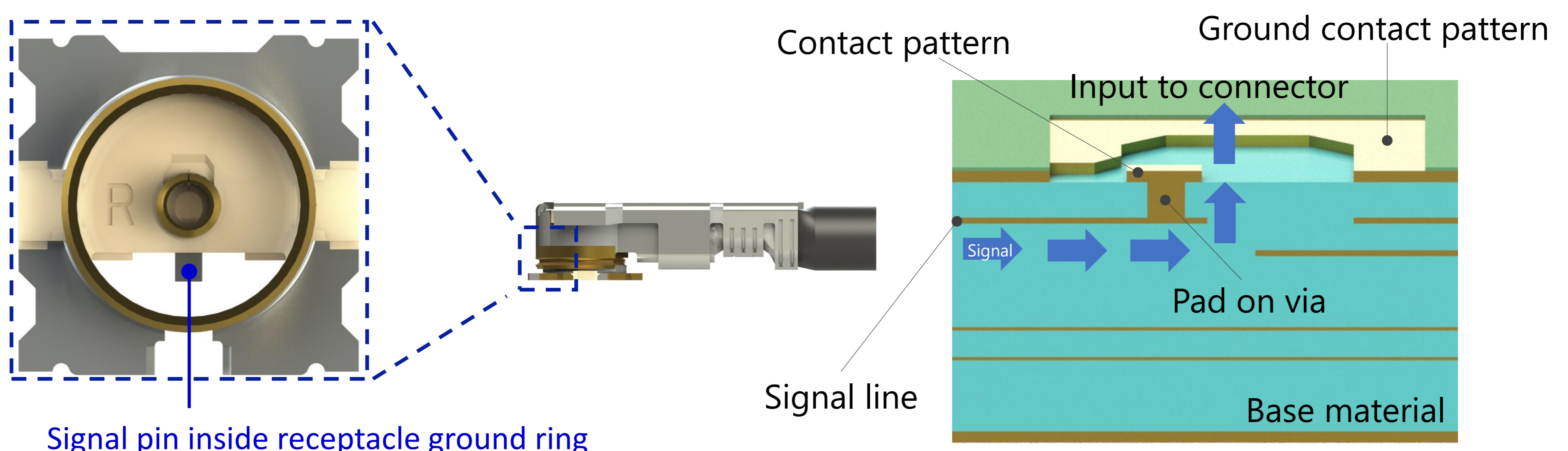

MHF® 7S standard harness

- ◆ Please click the part number to get its 2D drawing.
- ◆ Please be advised that if it becomes necessary to change the harness specifications, the part number will also need to be updated. The following part number is valid only when used with the harness specifications shown below.
- ◆ Please contact us via [Inquiry form](#) for other harness specifications.

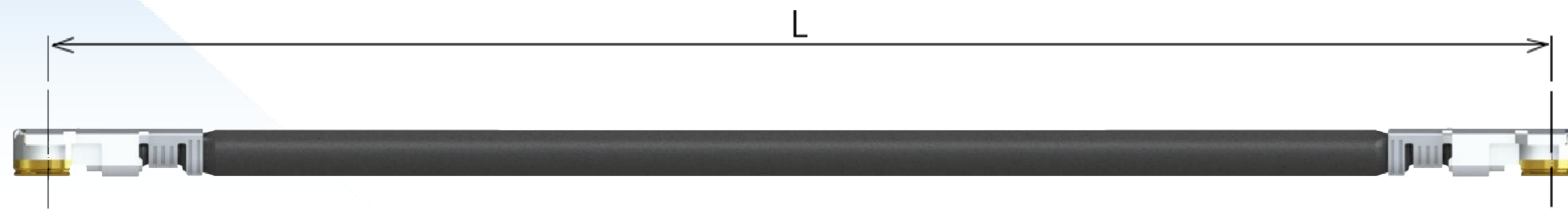

Part Number Description	Part Number (Link to Drawing)	Sample available
MHF 7S-7S harness OD=1.13 mm L=50 mm	8-24-0162	Contact us
MHF 7S-7S harness OD=1.13 mm L=100 mm	8-22-0127	Buy from Digikey
MHF 7S-7S harness OD=1.13 mm L=150 mm	8-23-0117	Buy from Digikey
MHF 7S-7S harness OD=1.13 mm L=200 mm	8-21-0046	Buy from Digikey
MHF 7S-7S harness OD=1.13 mm L=500 mm	8-24-0163	Contact us

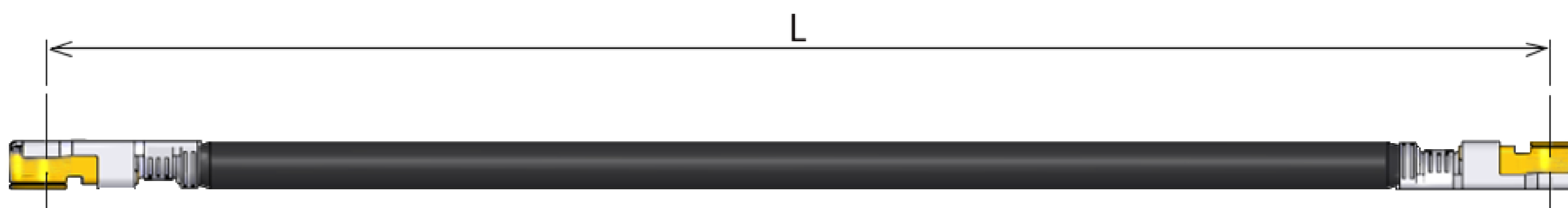

Part Number Description	Part Number (Link to Drawing)	Sample available
MHF 7S-7S harness OD=1.13 mm L=100 mm 180 degree orientation	8-25-0941	Contact us
MHF 7S-7S harness OD=1.13 mm L=200 mm 180 degree orientation	8-25-0943	Contact us

Component Parts Details

MHF® 7S plug

Recommended P/N	20980-001R-13
PART NO.	20980-001R-13

Offered as harness only.

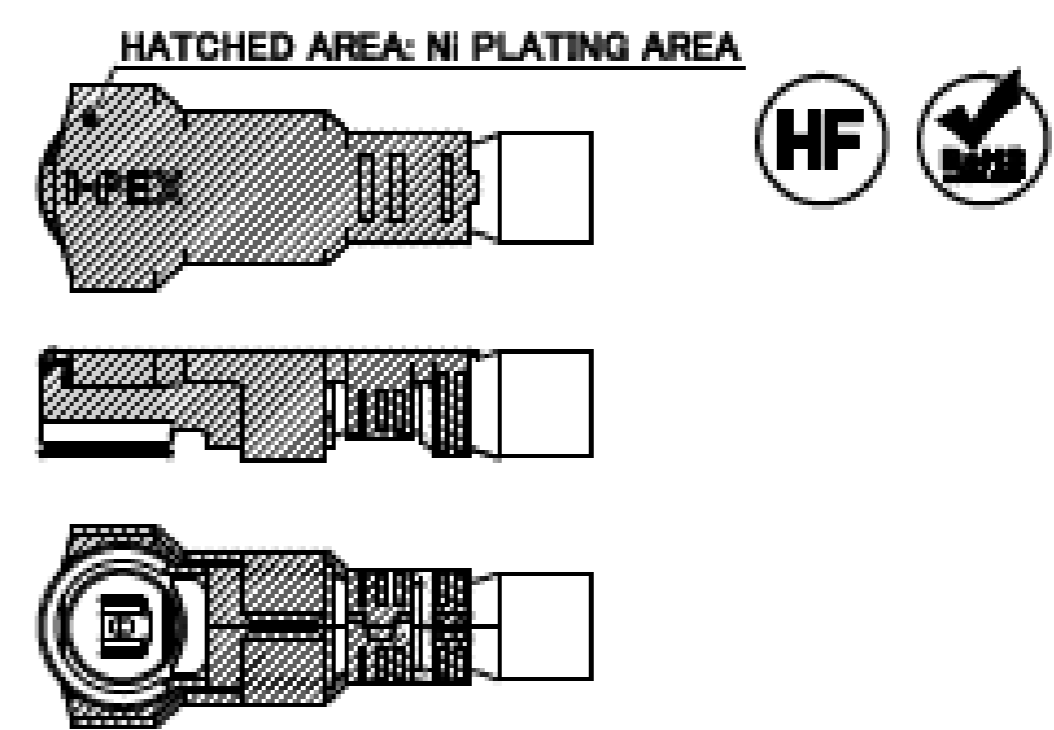
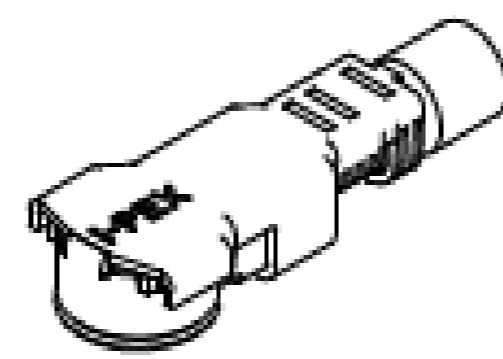
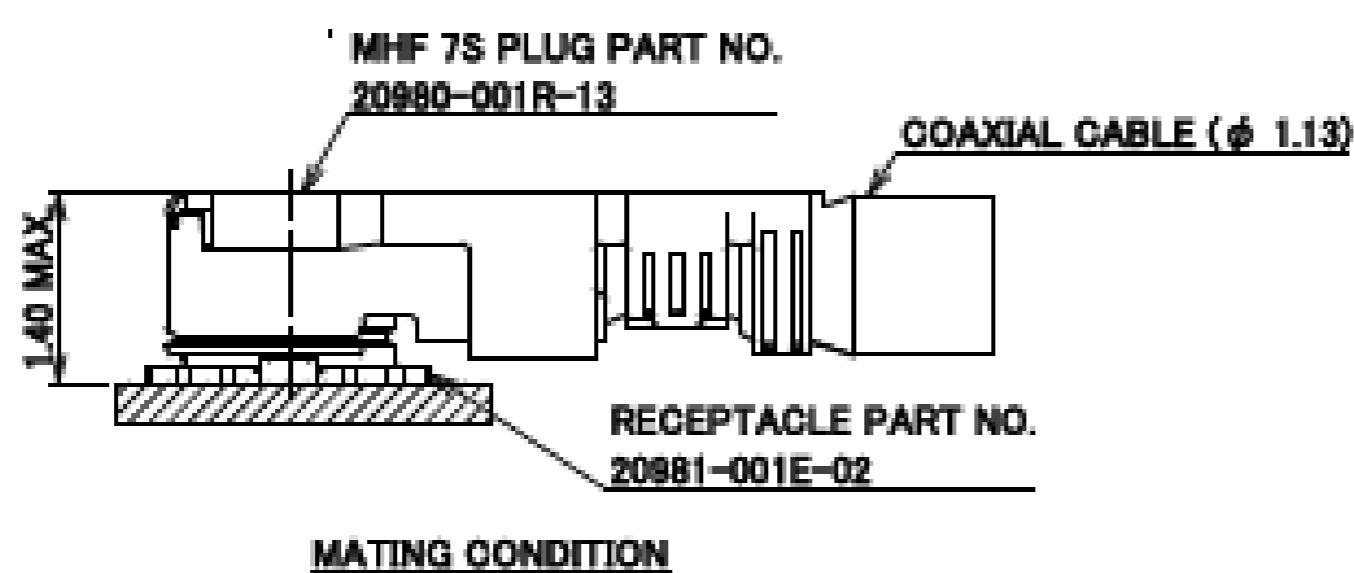
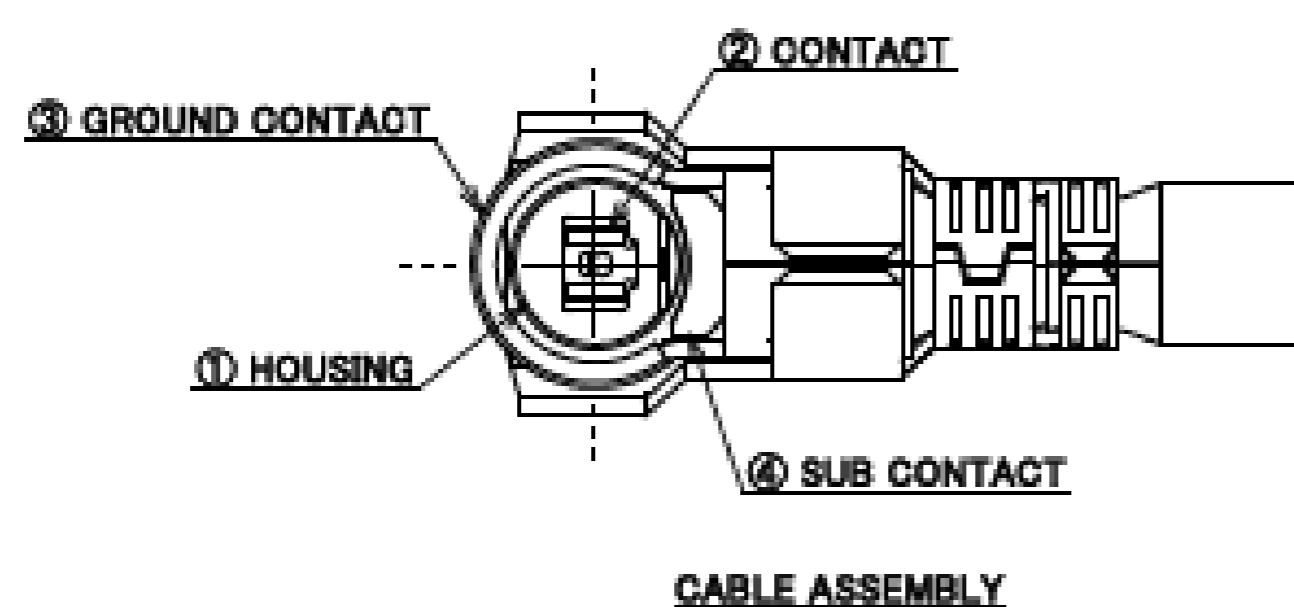
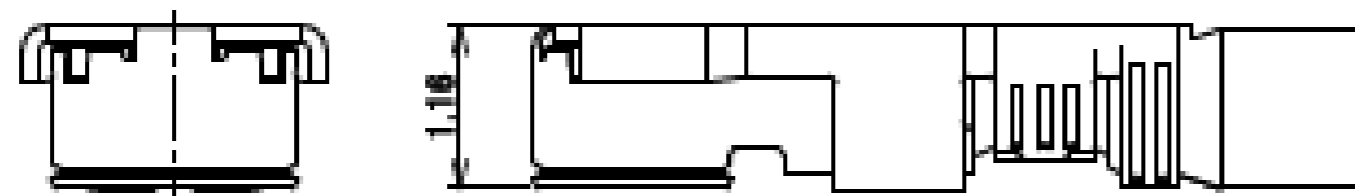
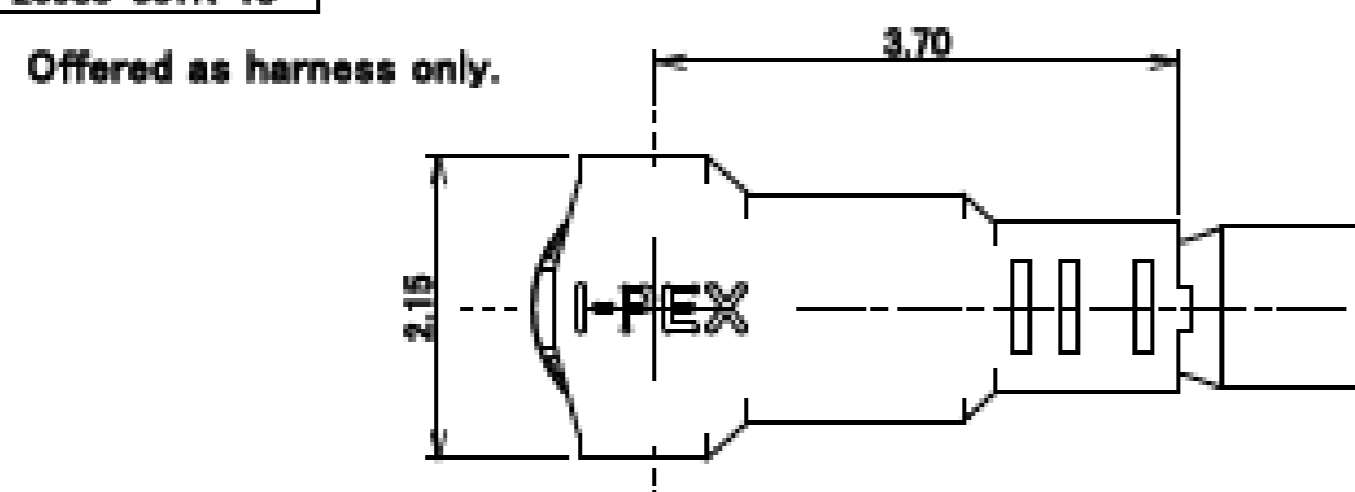

NOTES

1. APPLICABLE CONNECTOR: 20981-001E-02
2. MATING AND UNMATING INSTRUCTION
 - 2-1. MATING
MATE THE CONNECTOR VERTICALLY AS MUCH AS POSSIBLE. ADJUSTING THE MATING AXIS OF PLUG AND RECEPTACLE. DO NOT SLANT MATE.
 - 2-2. UNMATING
USE THE MATING AND UNMATING TOOL (PART NO. 91186-0001) AS THE FOLLOWING DRAWING, AND PULL PLUG TO VERTICAL DIRECTION AS DIRECTLY AS POSSIBLE.
3. PERMISSIBLE LOAD OF CABLE AT MATING.
4. CHARACTERISTIC IMPEDANCE: 50 Ω (NOMINAL VALUE)

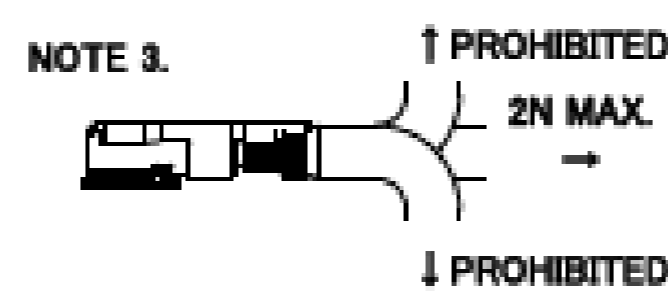

NO.	DESCRIPTION	MATERIAL	FINISH, REMARKS
4	SUB CONTACT	PHOSPHOR BRONZE	ALL OVER: Ni 1.00 μm MIN. CONTACT PART: Au 0.1 μm MIN.
3	GROUND CONTACT	PHOSPHOR BRONZE	ALL OVER: Ni 0.7 μm MIN. CONTACT PART: Au 0.1 μm MIN. (Ni PLATING AREA) Ni ONLY
2	CONTACT	CORSON ALLOY	ALL OVER: Ni 1.00 μm MIN. CONTACT PART: Au 0.1 μm MIN.
1	HOUSING	LGP	UL94V-0, WHITE

MHF® 7S plug

ITEMS	SPECIFICATION
APPLICABLE CONNECTOR PART No.	20981-001E-02
RATING VOLTAGE	60 V AC (R.M.S)/DC
RATING FREQUENCY	DC~15 GHz
OPERATING TEMPERATURE	233~363 K (-40°C~+90°C)
OPERATING HUMIDITY	90% MAX. (NON-CONDENSING)
CHARACTERISTIC IMPEDANCE	50 ohm (NOMINAL VALUE)
VSWR	1.30 MAX. AT 0.1 ~ 3 GHz, 1.35 MAX. AT 3 ~ 6 GHz, 1.40 MAX. AT 6 ~ 9 GHz, 1.45 MAX. AT 9 ~ 12 GHz, 1.50 MAX. AT 12 ~ 15 GHz
MAIN CONTACT RESISTANCE	INITIAL : 20 mohm MAX. / AFTER TEST : Δ R 20 mohm MAX.
GROUND CONTACT RESISTANCE	INITIAL : 20 mohm MAX. / AFTER TEST : Δ R 20 mohm MAX.
INSULATION RESISTANCE	INITIAL : 500 Mohm MIN. / AFTER TEST : 100 Mohm MIN.
DIELECTRIC WITHSTANDING VOLTAGE	AC200V 1min
DURABILITY	30 CYCLES
MATING FORCE (INITIAL / AFTER TEST)	INITIAL: 30N MAX. (VERTICAL DIRECTION) AFTER TEST: 30N MAX. (VERTICAL DIRECTION)
UNMATING FORCE (INITIAL / AFTER TEST)	INITIAL: 20N MAX., 5N MIN. (VERTICAL DIRECTION) AFTER TEST: 20N MAX., 3N MIN. (VERTICAL DIRECTION)
CRIMP STRENGTH	10N MIN.
PRODUCT SPECIFICATION	PRS-2676
TEST REPORT	TR-20043
INSTRUCTION MANUAL	HIM-19009
APPEARANCE CRITERIA No.	QLS-A***

Rev.4

Accessories for MHF® 7S plug

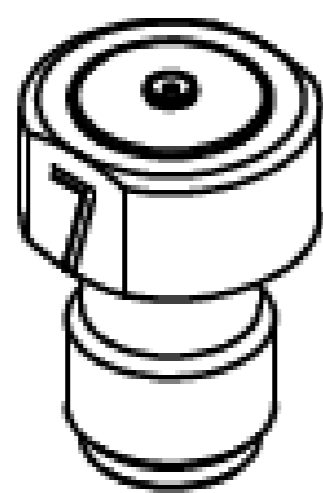

MHF 7 (S) PLUG SMA ADAPTER
PART NO. 91255-0001

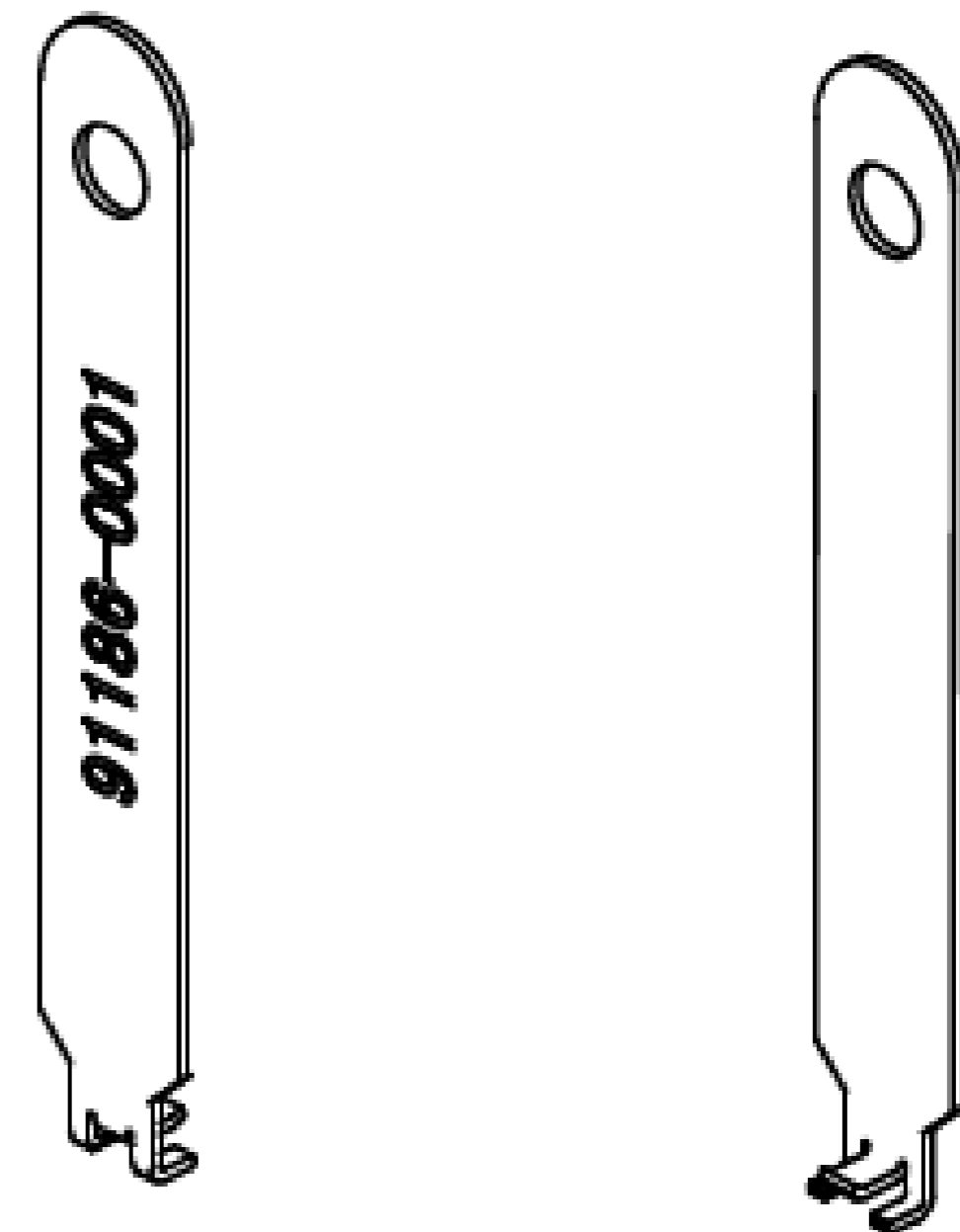

MHF 7S MATING AND UNMATING TOOL
PART NO. 91186-0001

Rev.4

MHF® 7S Receptacle

Recommended P/N	20981-001E-02
PART NO.	20981-001E-02

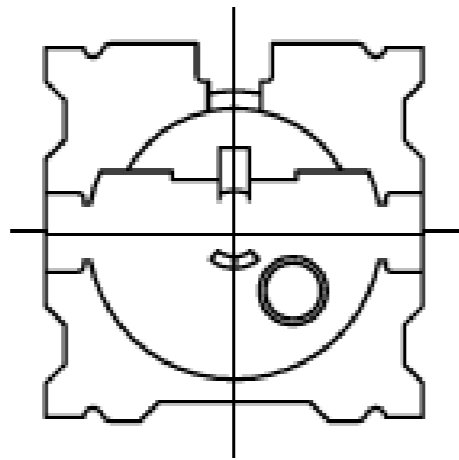
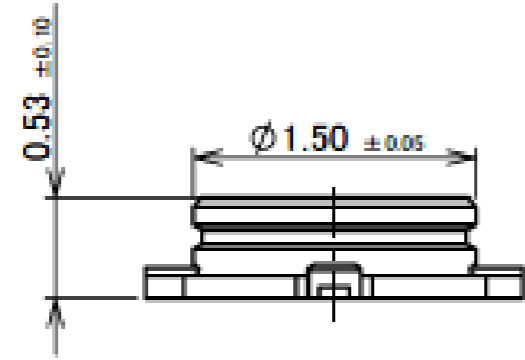
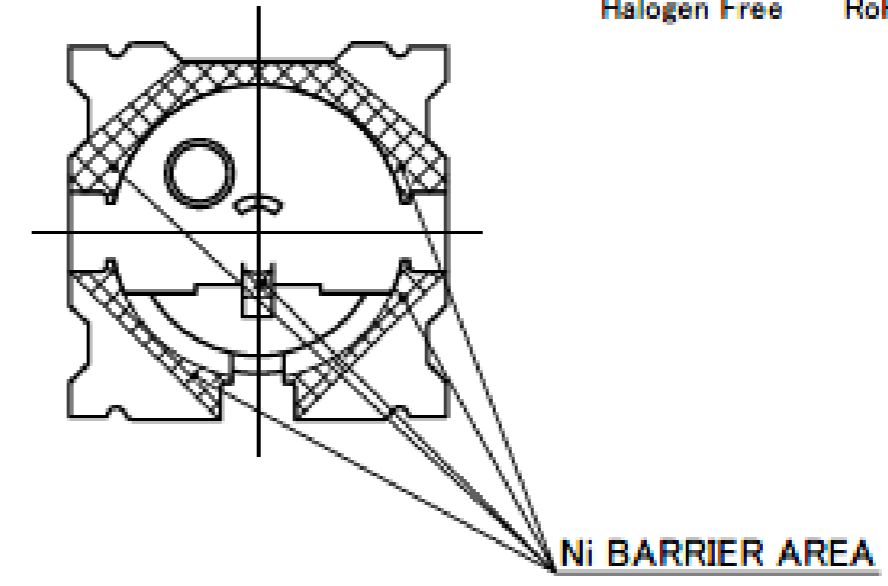
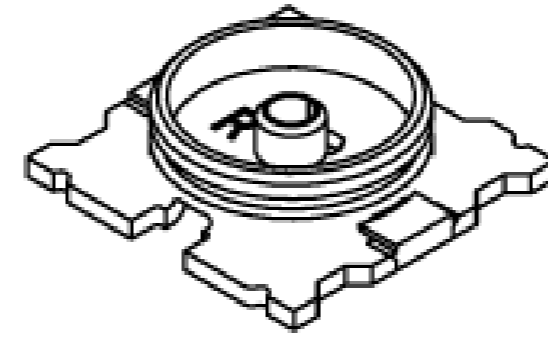
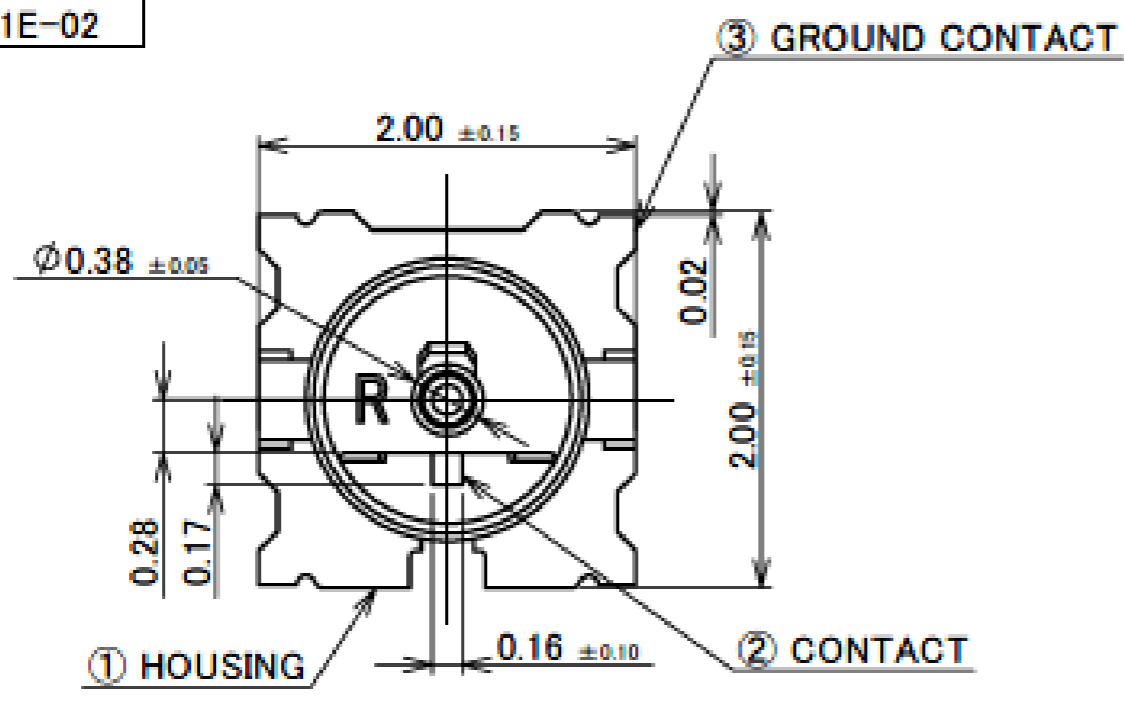

- NOTES
1. APPLICABLE CONNECTOR
20980-001R-13
 2. COPLANARITY: 0.08mm MAX.
 3. CHARACTERISTIC IMPEDANCE: 50Ω (NOMINAL VALUE)

NO.	DESCRIPTION	MATERIAL	FINISH, REMARKS
3	GROUND CONTACT	PHOSPHOR BRONZE	ALL OVER: Ni 1.00 μm MIN. CONTACT PART: 0.05 μm MIN. SOLDERING PART Au AREA: 0.02 μm MIN.
2	CONTACT	CORSON ALLOY	ALL OVER: Ni 1.00 μm MIN. CONTACT PART: 0.1 μm MIN. SOLDERING PART Au AREA: 0.02 μm MIN.
1	HOUSING	LCP	UL94V-0, WHITE

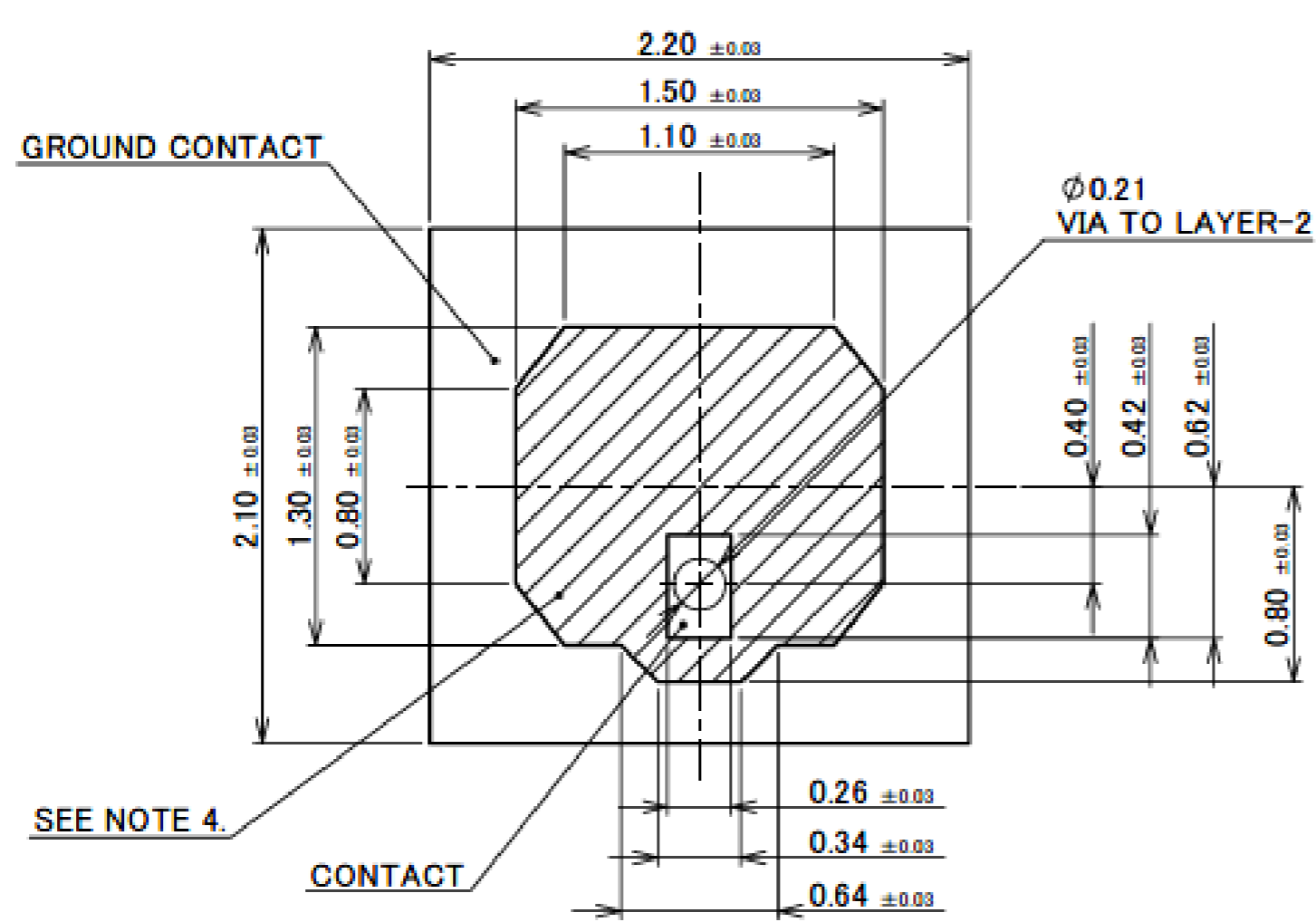
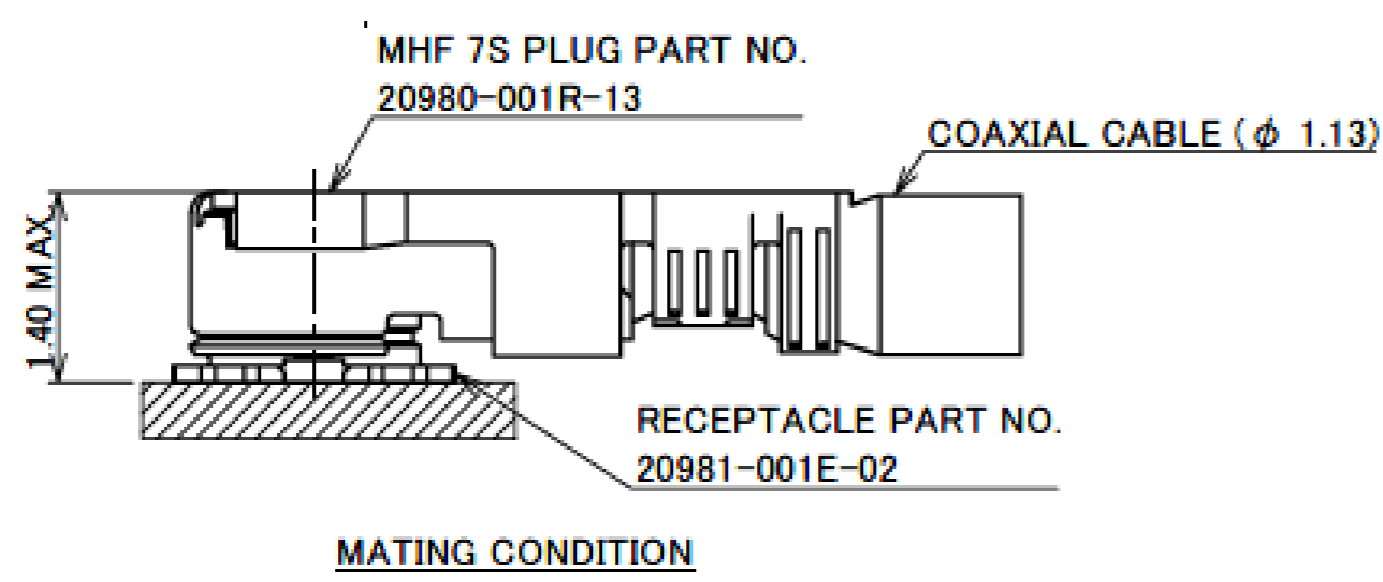

RECOMMENDED FOOTPRINT PATTERN

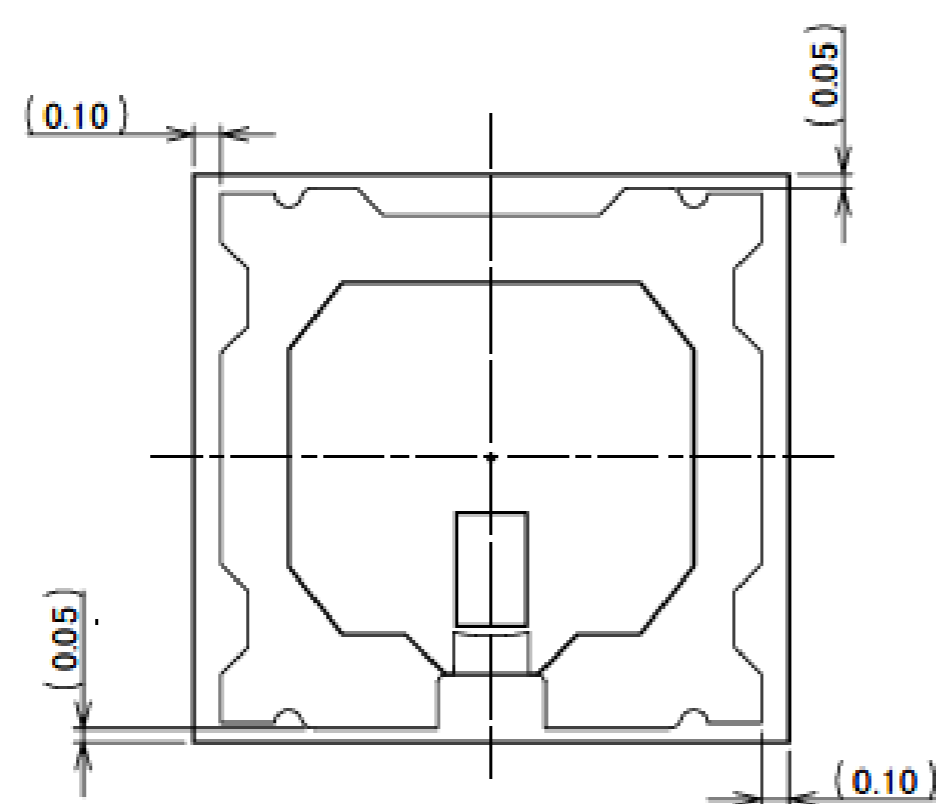

CONNECTOR ON RECOMMENDED FOOTPRINT PATTERN

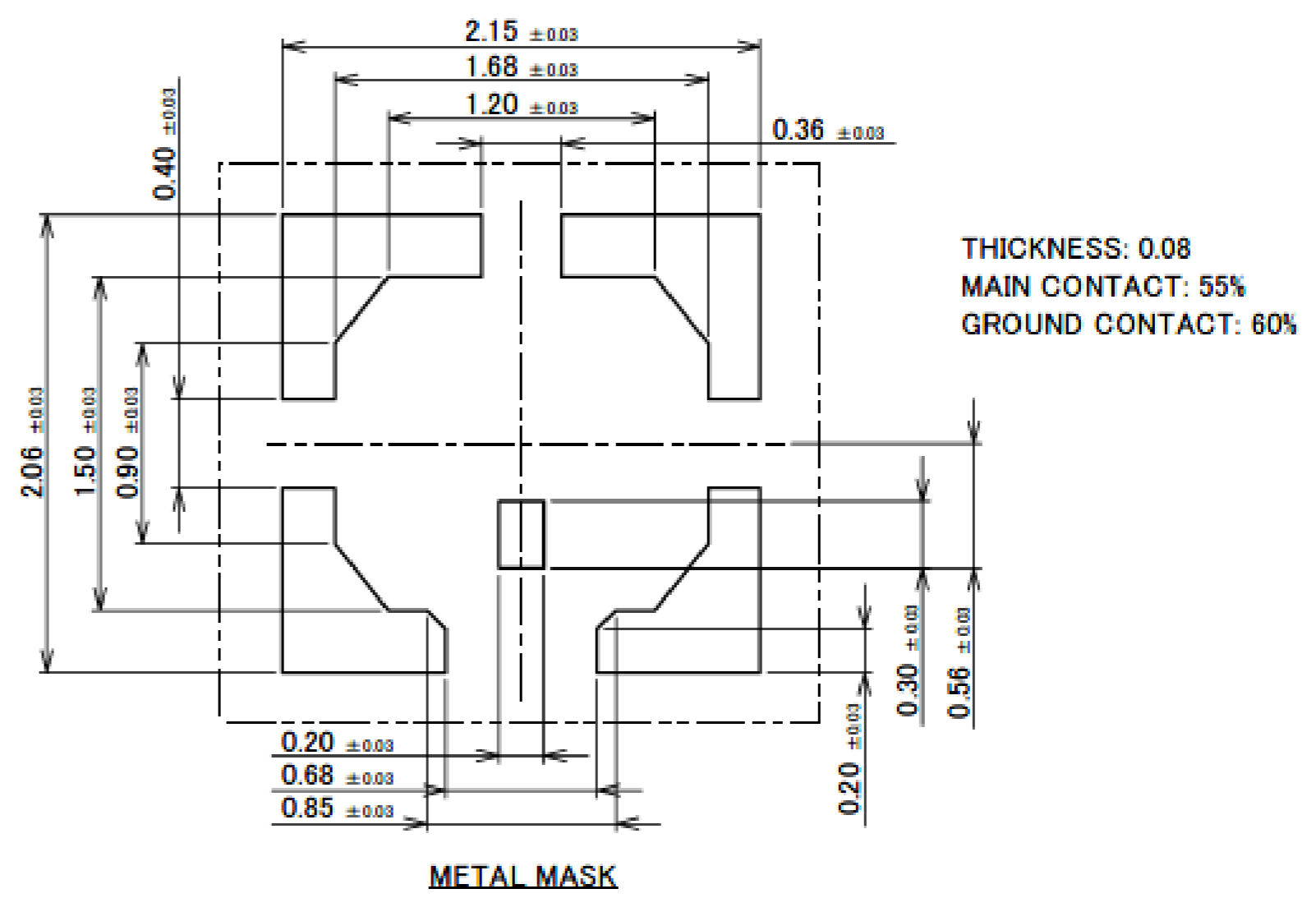

METAL MASK

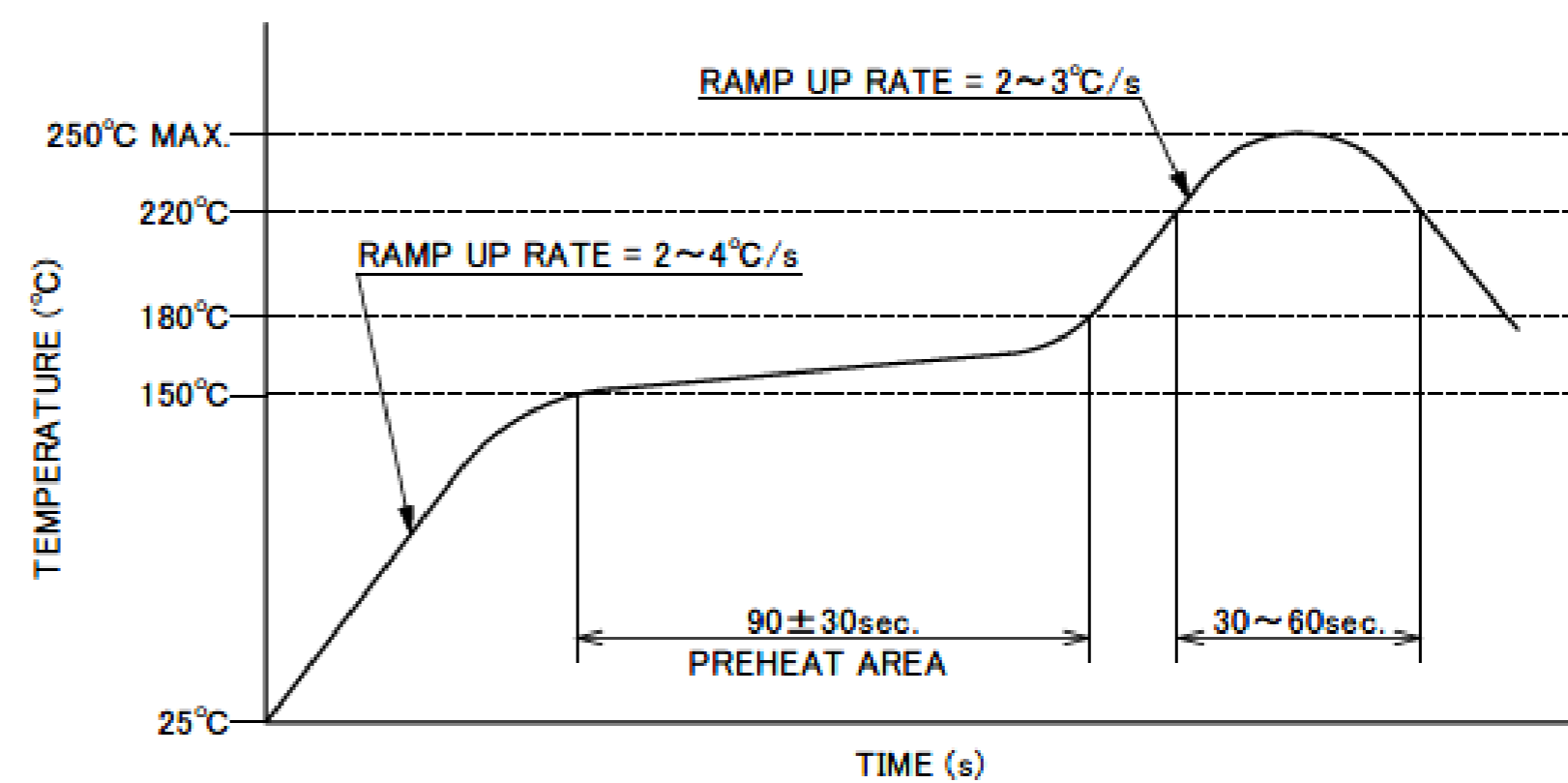

REFLOW TEMPERATURE PROFILE
SENJU METAL INDUSTRY CO., LTD. : M705-SHF(Sn96.5 Ag3.0 Cu0.5)

- NOTES
4. NO GROUND, SIGNAL, AND RESIST IN THIS AREA.

MHF® 7S Receptacle

ITEMS	SPECIFICATION
APPLICABLE CONNECTOR PART No.	20980-001R-13
RATING VOLTAGE	60 V AC (R.M.S)/DC
RATING FREQUENCY	DC~15 GHz
OPERATING TEMPERATURE	233~363 K (-40°C~+90°C)
OPERATING HUMIDITY	90% MAX. (NON-CONDENSING)
CHARACTERISTIC IMPEDANCE	50 ohm (NOMINAL VALUE)
VSWR	1.30 MAX. AT 0.1 ~ 3 GHz, 1.35 MAX. AT 3 ~ 6 GHz, 1.40 MAX. AT 6 ~ 9 GHz, 1.45 MAX. AT 9 ~ 12 GHz, 1.50 MAX. AT 12 ~ 15 GHz
MAIN CONTACT RESISTANCE	INITIAL : 20 mohm MAX. / AFTER TEST : \leq 20 mohm MAX.
GROUND CONTACT RESISTANCE	INITIAL : 20 mohm MAX. / AFTER TEST : \leq 20 mohm MAX.
INSULATION RESISTANCE	INITIAL : 500 Mohm MIN. / AFTER TEST : 100 Mohm MIN.
DIELECTRIC WITHSTANDING VOLTAGE	AC200V 1min
DURABILITY	30 CYCLES
MATING FORCE (INITIAL / AFTER TEST)	INITIAL: 30N MAX. (VERTICAL DIRECTION) AFTER TEST: 30N MAX. (VERTICAL DIRECTION)
UNMATING FORCE (INITIAL / AFTER TEST)	INITIAL: 20N MAX., 5N MIN. (VERTICAL DIRECTION) AFTER TEST: 20N MAX., 3N MIN. (VERTICAL DIRECTION)
CRIMP STRENGTH	10N MIN.
PRODUCT SPECIFICATION	PRS-2676
TEST REPORT	TR-20043
PACKING STANDARD	PST-19094
INSTRUCTION MANUAL	HIM-19009
APPEARANCE CRITERIA No.	QLS-A***

Rev.5

Accessories for MHF® 7S Receptacle

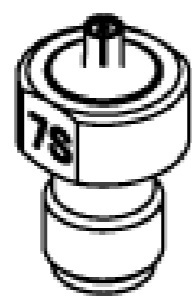

MHF 7S RECEPTACLE SMA ADAPTER
PART NO. 91256-0001

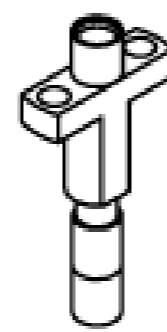

MHF 7S RECEPTACLE HIGH CYCLE N30 SMPM ADAPTER
PART NO. 91145-0001

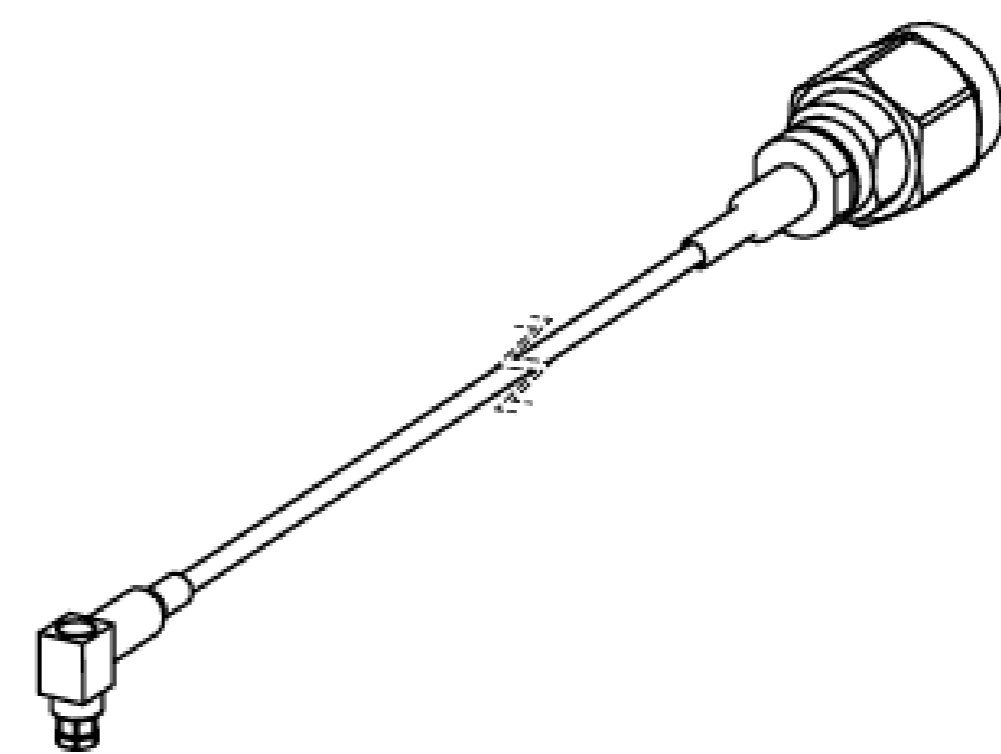

MHF SERIES N30 SMPM TO SMA ADAPTER CABLE
PART NO. 91197-300*

* 91145-0001 AND 91197-300* SHOULD BE USED TOGETHER.

Rev.5

Custom Connectors Available

RF Connectors

MHF® series

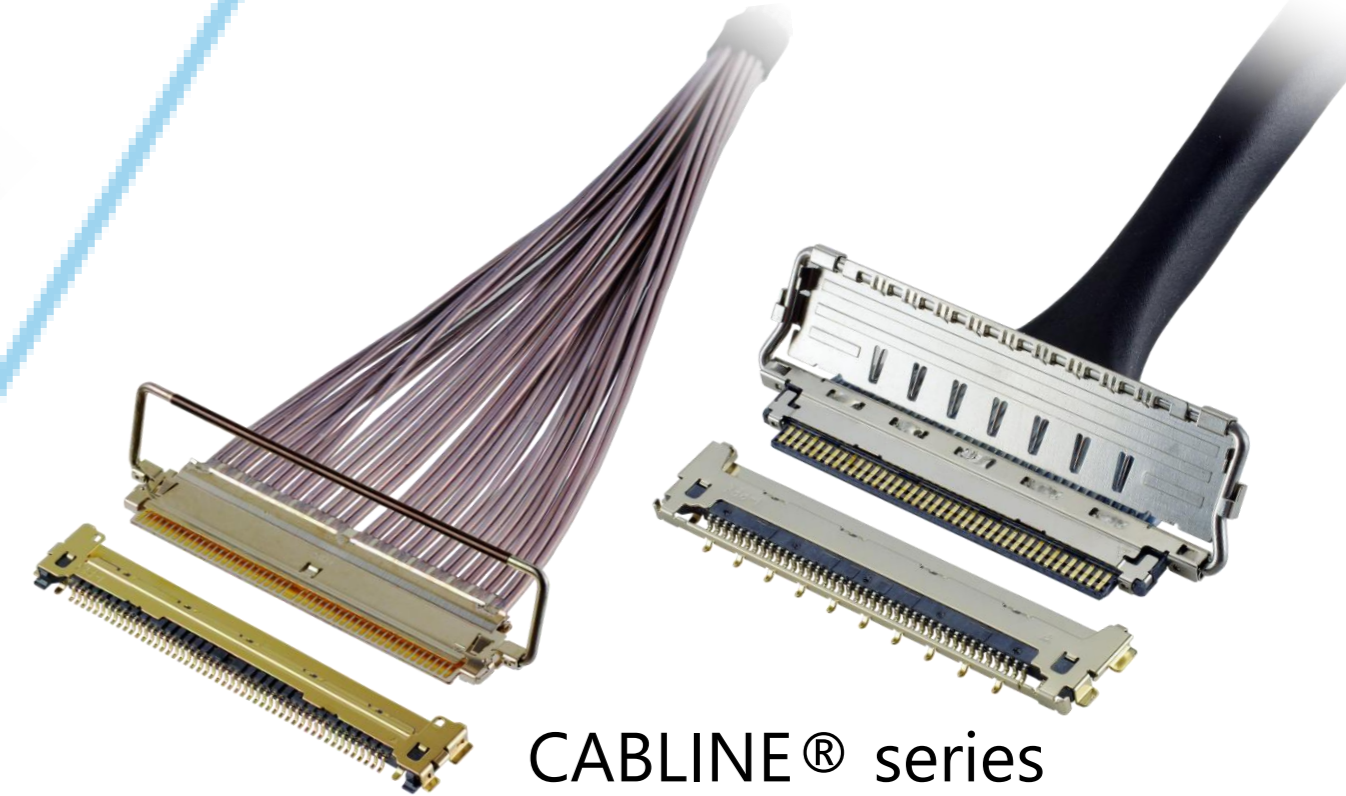

CABLINE® series

Micro-Coaxial/Twinaxial Connectors



Wire-to-Board Connectors/Terminals

AP series



ISH® series

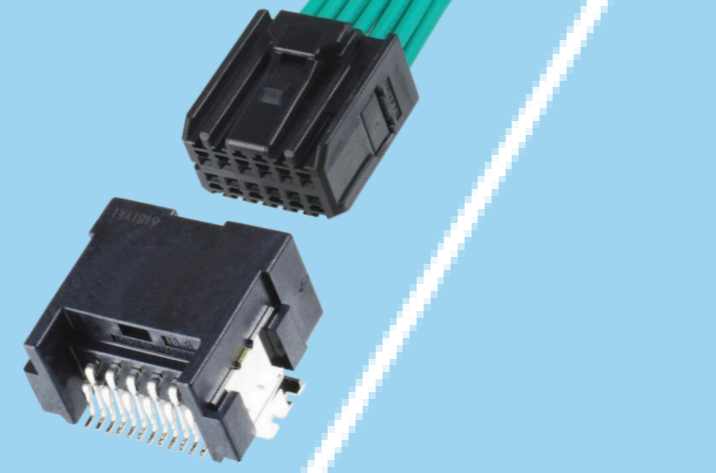

NOVASTACK® series

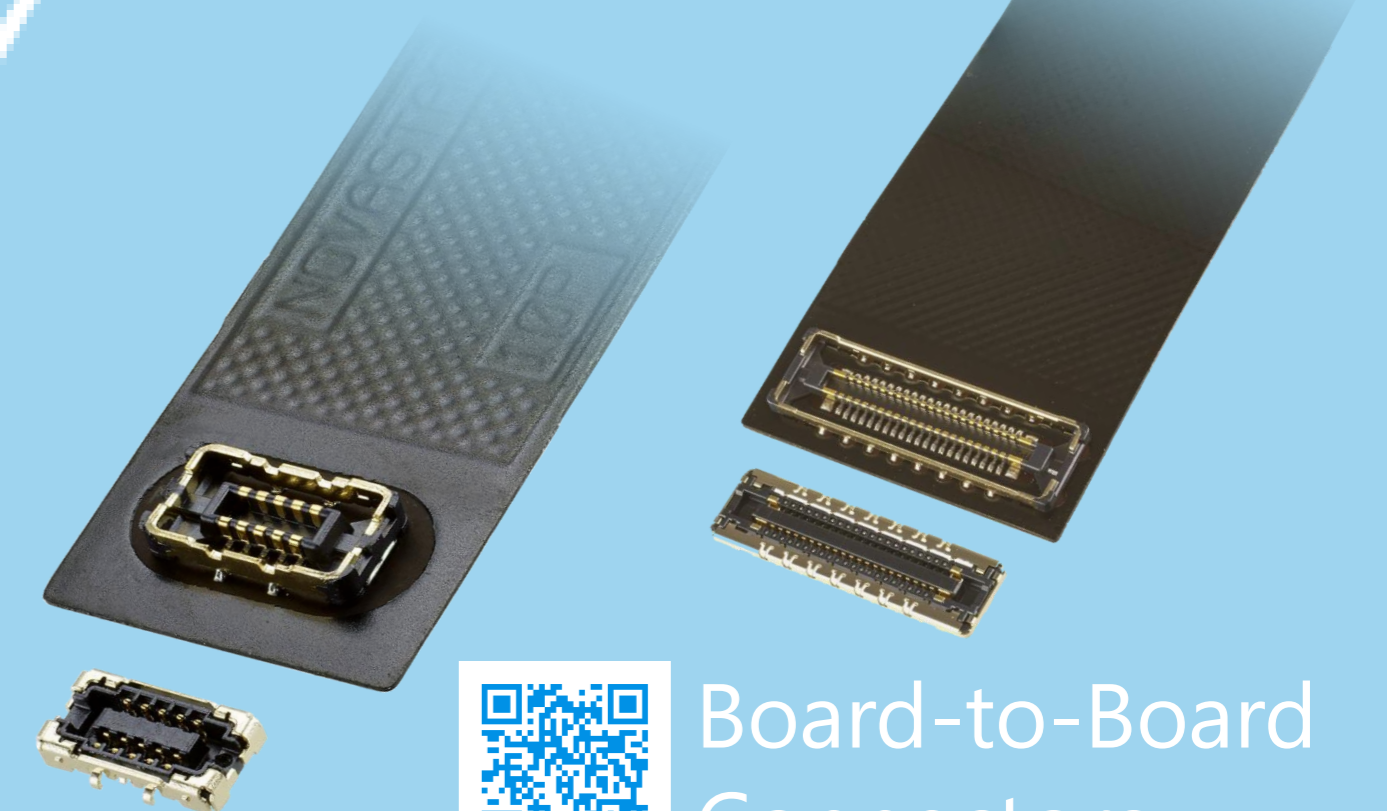

Board-to-Board Connectors



I/O Connectors

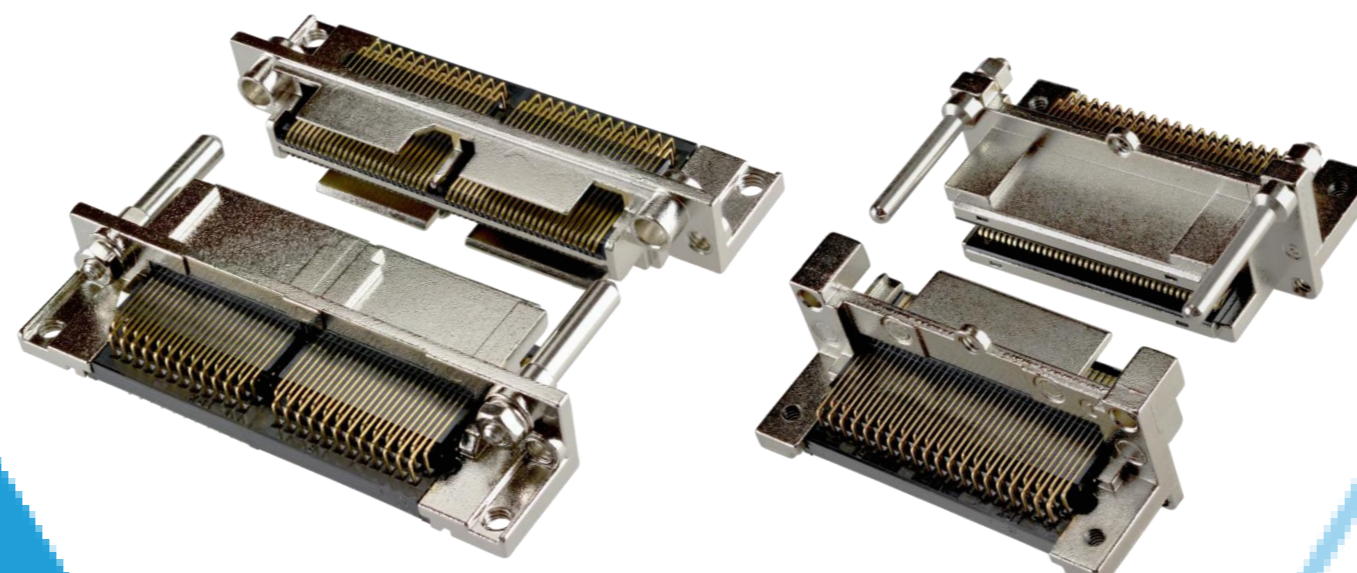

MINIDOCK™ series

MINIFLEX® series EVAFLEX® series



FPC/FFC Connectors



Inquiry



I-PEX, MHF, CABLINE, NOVASTACK, ISH, IARPB, MINIFLEX, EVAFLEX, MINIDOCK, i-Fit and ZenShield are registered trademarks of I-PEX Inc. Please note that the contents in the catalog might be changed without prior notification. I-PEX Inc. assumes no responsibility for any inaccuracies or obligation to update Information on these documents. Please be sure to read and understand the latest "Precautions for Use" and "Instruction Manual" before you use our products. We shall not be responsible for any defects, damages or troubles in case you use our products without following the precautions for use. Please feel free to contact our sales representatives when you use our products for any applications that require very high reliability and safety, or that relate to human life (ex. nuclear power control, aerospace, transportation, medical equipment, safety equipment etc.).

Contact your sales representative or more detailed information.

www.i-pex.com

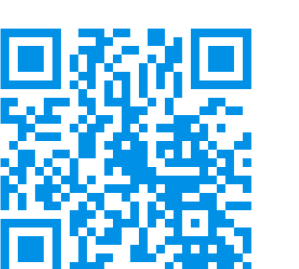

I-PEX

© I-PEX Inc. 2026
All rights reserved