

PART NUMBER
138-0407-021

REV	ECO	DATE
1	INITIAL RELEASE	05MAR2021

NOTES:

1. MATERIAL AND FINISH:

- 1.1 BODY: BRASS, NICKEL PLATE
- 1.2 CONTACT: BRASS, GOLD PLATE
- 1.3 INSULATOR: PTFE
- 1.4 GASKET: SILICONE RUBBER, RED
- 1.5 RETENTION SPRING: PHOSPHOR BRONZE
- 1.6 COUPLING NUT: BRASS, NICKEL PLATE
- 1.7 FERRULE: BRASS, NICKEL PLATE

2. ELECTRICAL SPECIFICATIONS:

- 2.1 IMPEDANCE: 50 OHMS NOMINAL
- 2.2 FREQUENCY RANGE: DC~4.0 GHz
- 2.3 VSWR: 1.30 MAX
- 2.4 INSERTION LOSS: 0.1 dB MAX
- 2.5 VOLTAGE RATING: 500 VRMS MAX
- 2.6 DIELECTRIC WITHSTANDING VOLTAGE: 1000 VRMS MIN
- 2.7 INSULATION RESISTANCE: 5000 MEGOHM MIN
- 2.8 CONTACT RESISTANCE:
 - 2.8.1 CENTER CONTACT – 3.0 MILLIOHM MAX
 - 2.8.2 OUTER CONDUCTOR – 1.0 MILLIOHM MAX

3. MECHANICAL SPECIFICATIONS:

- 3.1 ENGAGE/DISENGAGE: 2.0 LBS MAX
- 3.2 COUPLING NUT TORQUE: 12-15 IN.LBS
- 3.3 DURABILITY: 500 CYCLES MIN

4. ENVIRONMENTAL:

- (MEETS OR EXCEEDS THE APPLICABLE PARAGRAPH OF MIL-PRF-39012)
- 4.1 THERMAL SHOCK: MIL-STD-202, METHOD 107, CONDITION B EXEPT 200°C HIGH TEMP
- 4.2 OPERATING TEMPERATURE: -65°C TO 165°C
- 4.3 MOISTURE RESISTANCE: MIL-STD-202, METHOD 106, LESS STEP 7b
- 4.4 MECHANICAL SHOCK: MIL-STD-202, METHOD 213, CONDITION I
- 4.5 VIBRATION: MIL-STD-202, METHOD 204, CONDITION D
- 4.6 CORROSION: MIL-STD-202, METHOD 101, CONDITION B

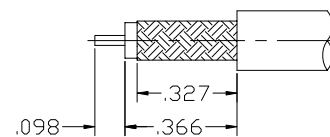
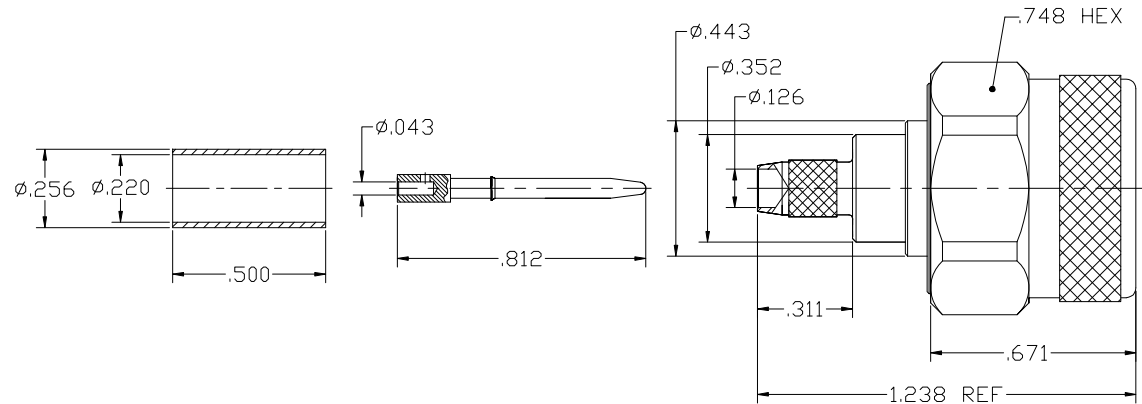

RECOMMENDED CABLE STRIPPING DIMENSIONS

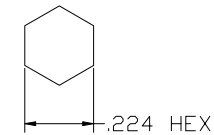

RECOMMENDED CRIMPING DIMENSIONS FOR FERRULE

<p>This PROPRIETARY Document is property of Cinch Connectivity Solutions. It is confidential in nature, non-transferable, and issued with the clear understanding that it is not traced or copied without permission and is returnable upon demand.</p> <p>INTERPRET DRAWING IN ACCORDANCE WITH ASME Y14.5-2009.</p>	Model No:	138-0407-021/030	JOHNSON	
	RoHS <input checked="" type="checkbox"/> (EU)/2015/863 COMPLIANT	Cage Code	Title: N-TYPE STRIGHT PLUG FOR RG58 CABLE	
	UNLESS OTHERWISE SPECIFIED UNITS: INCH	3RD ANGLE PROJECTION	Drawing No.	REV.
	.XXX±.008 .XXXX±.004 ANGLES±5°	Drawn by: BILL PENG Date: 03/05/2021	138-0407-021/030	1
	Size	DO NOT SCALE DRAWING	Workmanship Std: NONE	Sheet 1 OF 1