

NOTES:

- MATERIAL**
 1.1 Housing: PBT UL94V-0;
 1.2 Shell: Brass;
 1.3 Contact pin: Phosphor Bronze;
- 2. FINISH**
 2.1 Contact Pin: Gold plating over Nickel;
 2.2 Shell: Nickel plated;
- 3. MECHANICAL**
 3.1 PCB retention pre-solder: 1 LB Min;
 3.2 PCB retention post-solder: 10 LB Min;
 3.3 Operating: 1500 Cycles Min;
- 4. ELECTRICAL**
 4.1 Current Rating: 1.5 AMP;
 4.2 Voltage Rating: 125 VAC
 4.3 Dielectric Strength: 1000 VAC 60Hz, 1 minute;
 4.4 Contact Resistance: 30mΩ max;
 4.5 Insulation Resistance: 1000 MΩ min, @ 500 VDC;
5. Operating temperature: -40°C TO +85°C;
 6. Storage temperature: -40°C TO +85°C;
 7. Wave Soldering temperature: 255~265°C for 5~10S;
 8. Packing: Tray;
 9. Mates with modular plug conforming to TIA-1096-A.

B

C

D

E

F

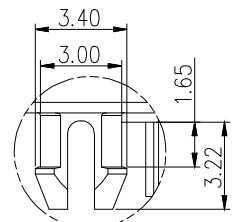
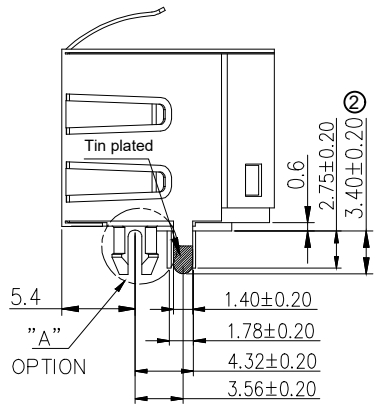
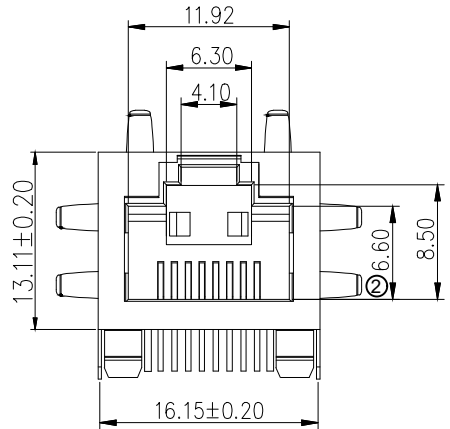



A-MJH-8-EA-xTP-S11

- G: Au flash
- P: Au 15u"
- H: Au 30u"
- L: Au 50u"

G

H

RoHS compliant
Unit:mm

Scale	Free					Date	Name	
TOLERANCE						Drawn	05.11.2021	Segal
X.X	±0.20					Approved	13.09.2023	Segal
X.XX	±0.15							
X.XXX	±0.10	②	Update the dimensions	13.09.2023	Segal			
DIM	TOL	①	Add page 2	28.03.2022	Segal	 A company of 		
		③	Drawn	05.11.2021	Segal			
Angle	±5°	Id.	Modification	Date	Name			

Description: Modular connector 8pins vertical CAT 5E

ASSMANN WSW-No.
A-MJH-8-EA-xTP-S11

Drawing-No.
ASS 9074 CO rev02

Customer-No. SHEET 1 / 2

1

2

3

4

5

6

7

1

2

3

4

5

6

7

A

B

C

D

E

F

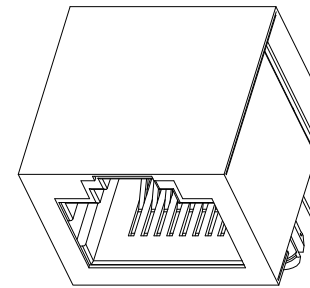
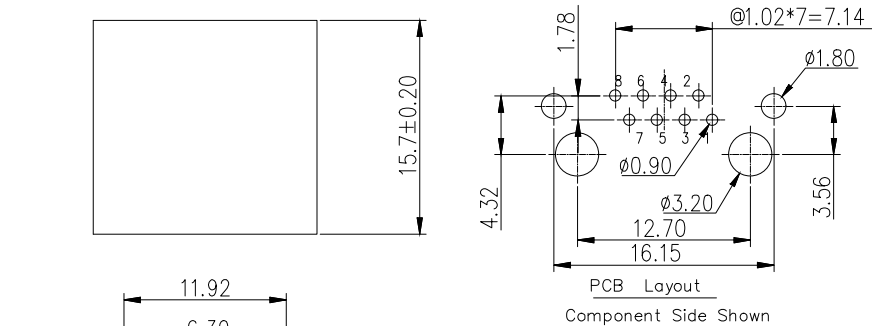

NOTES:

MATERIAL

- 1.1 Housing: PBT UL94V-0;
1.2 Shell: Brass;
1.3 Contact pin: Phosphor Bronze;

2. FINISH

- 2.1 Contact Pin: Gold plating over Nickel;
2.2 Shell: Nickel plated;

3. MECHANICAL

- 3.1 PCB retention pre-solder: 1 LB Min;
3.2 PCB retention post-solder: 10 LB Min;
3.3 Operating: 1500 Cycles Min;

4. ELECTRICAL

- 4.1 Current Rating: 1.5 AMP;
4.2 Voltage Rating: 125 VAC
4.3 Dielectric Strength: 1000 VAC 60Hz, 1 minute;
4.4 Contact Resistance: 30mΩ max;
4.5 Insulation Resistance: 1000 MΩ min, @ 500 VDC;

5. Operating temperature: -40°C TO +85°C;
6. Storage temperature: -40°C TO +85°C;
7. Wave Soldering temperature: 255~265°C for 5~10S;
8. Packing: Tray;
9. Mates with modular plug conforming to TIA-1096-A.

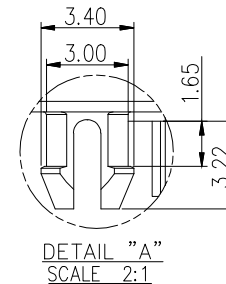
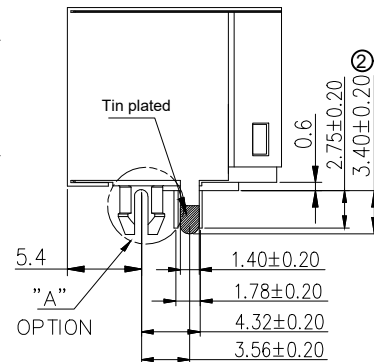
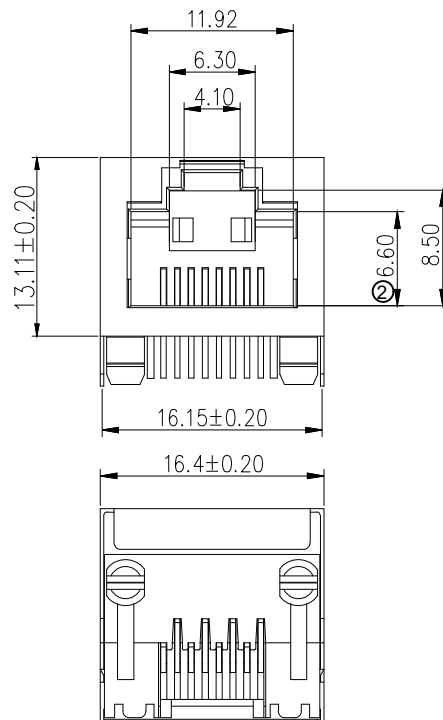

A-MJH-8-EA-xTP-S10

- G: Au flash
P: Au 15u"
H: Au 30u"
L: Au 50u"

A

B

C

D

E

F

G

H

G

H

RoHS compliant

Unit:mm

Scale Free

TOLERANCE

X.X ±0.20

X.XX ±0.15

X.XXX ±0.10

DIM TOL

Angle ±5°

② Update the dimensions

① Add page 2

① Drawn

Id.

Modification

Date

Name

Date

Name

Drawn

05.11.2021

Segal

Approved

13.09.2023

Segal

ASSMANN
WSW components

A company of **BS**Description: Modular connector 8pins
vertical CAT 5E

ASSMANN WSW-No.

A-MJH-8-EA-xTP-S10

Drawing-No.

ASS 9074 CO

rev02

Customer-No.

SHEET
2 / 2

1

2

3

4

5

6

7

CON1507