

HR30 Series

Miniature Waterproof Plastic Connectors

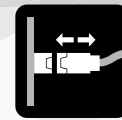

Push On



Waterproof



Compact



Features

1. Compact, Low-Profile Design

3 & 6 pos: Outer diameter ϕ 12.6mm max; mating height: 32.3mm (from panel surface)

10 & 12 pos: Outer diameter ϕ 15.5mm max; mating height: 42.1mm (from panel surface)

Mating Diagram

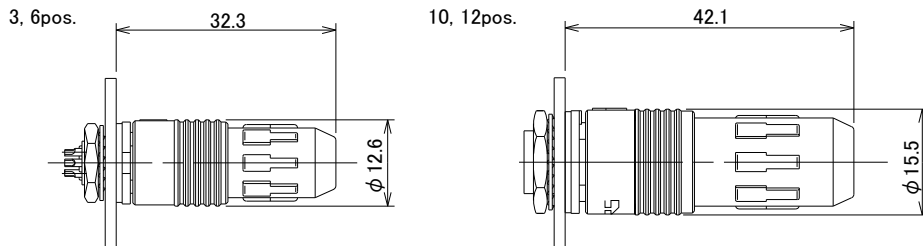

2. Waterproof Design

IPX7 and IPX8 waterproof performance when mated.

- IPX7: Immersed in 1 meter of water for 30 minutes (mated)
- IPX8: Immersed in 2 meters of water for 14 days (mated)

3. User-Friendly Push-Pull Lock

Unique locking mechanism enables easy mating and unmating—even with waterproof construction.

Lock Design

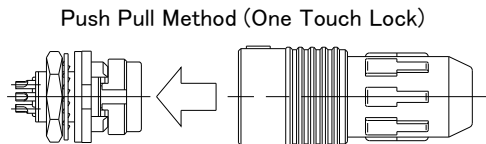

4. Lightweight Construction

- 3 & 6 pos: 6g (plug + receptacle)
- 10 & 12 pos: 9g (plug + receptacle)

5. Simple Clamp Structure

Cable is securely clamped by tightening the cord tube.

6. Secure 360° Locking

Locks reliably from any rotational angle for robust mating.

7. Mis-insertion Prevention

Multi-key guide system ensures proper mating alignment.

8. Easy Alignment with Mating Marks

White position marks on both plug and receptacle aid in visual alignment.

9. RoHS2 Compliant

All materials comply with the RoHS directive to support environmental responsibility.

10. High-Speed Data Transmission

Supports Cat5e (1Gbps) Ethernet

- ISO TR 11801-9902 Class D3 - Conn E3 (End-to-End)
- Performance depends on pin assignment, cable, and assembly.
- Please consult Hirose for recommended pin configurations.

11. Suitable for Long-term Outdoor Use

Passed 2,000-hour sunshine weather meter test for long-term UV durability.

Product Specifications

Rated Current	5A (3pos.) 2A (6, 10, 12pos.)	Operating Temperature	-25 to +85°C
Rated Voltage	100V AC, 140V DC (3, 6pos.) 30V AC, 42V DC (10, 12pos.)	Storage Temperature	-10 to +60°C

Item	Specification	Conditions
Contact Resistance	5mΩ Max. (3pos.) 15mΩ Max. (6, 10, 12pos.: Crimp Type) 30mΩ Max. (6, 12pos.: Dip Type)	Measured at 1A DC
Insulation Resistance	1000MΩ Min.	Measured at 100V DC
Withstanding Voltage	No flashover and insulation breakdown	300V AC for 1 min.
Vibration Resistance	No electrical discontinuity of 10 μs or more	10 to 55 to 10Hz/cycle, amplitude 0.75mm, at 5 minutes/cycle Test 10 cycles each in 3 axial directions
Mating Durability	Contact Resistance: 10mΩ Max. (3pos.) 30mΩ Max. (6, 10, 12pos.: Solder Type) 60mΩ Max. (6, 12pos.: Through Hole Type)	1000 times
Temperature Cycles	Insulation Resistance: 100MΩ Min.	Temperature: -55°C → room temperature → +85°C → room temperature Time: 30 → 10 to 15 → 30 → 10 to 15 min. Repeated for 5 cycles.
Humidity Resistance	Insulation Resistance: 10MΩ Min. (High Humidity) 100MΩ Min. (Dry)	96 hours at temperature of 40°C and humidity of 90% to 95%
Water Resistance	No water intrusion inside connector	At a water depth of 1.0 meters for 0.5 hours in mated condition.

Materials / Finish

Item	Part	Material	Color/Finish
Plug	Outer Shell/ Insulator	PPS	Black
		PBT	Black
		Polyacetal Resin	Natural
	Gasket	SIR/CR	Red/Black
	Male Contact/Female Contact	Brass, Phosphor Bronze, Copper Alloy	Gold Plating
	Spring	Stainless Steel	-
Receptacle	Outer Shell/ Insulator	PPS	Black
	Gasket	CR	Black
	Male Contact/Female Contact	Brass, Phosphor Bronze, Copper Alloy	Gold Plating
	Hex Nut	Brass	Nickel Plating
	Washer	Phosphor Bronze	Nickel Plating
Crimp Contact	Male Contact	Phosphor Bronze	Partial Gold Plating
	Female Contact	Phosphor Bronze	Partial Gold Plating

Product Number Structure

Refer to the chart below when determining the product specifications from the product number. Please select from the product numbers listed in this catalog when placing orders.

HR30 - 6 P A - 6 S C (##)

- ① ② ③ ④ ⑤ ⑥ ⑦ ⑧

① Series Name	HR30	⑤ No. of Pos.	3, 6, 10, 12
② Shell Size	Outer diameter of plug mated portion	⑥ Contact Gender	S: Female Contact P: Male Contact
③ Connector Type	P: Plug R: Receptacle J: Jack	⑦ Contact Assembly	None: Solder Termination C: Crimp Termination D: Through hole
④ Classification of connectors within the same type	None: Standard A: Thin Cable B, D: Integrated Molding Type	⑧ Other Specifications	If there are specification changes other than items 1 to 7, a two-digit number will be appended.

Connector Mating Combination Diagram

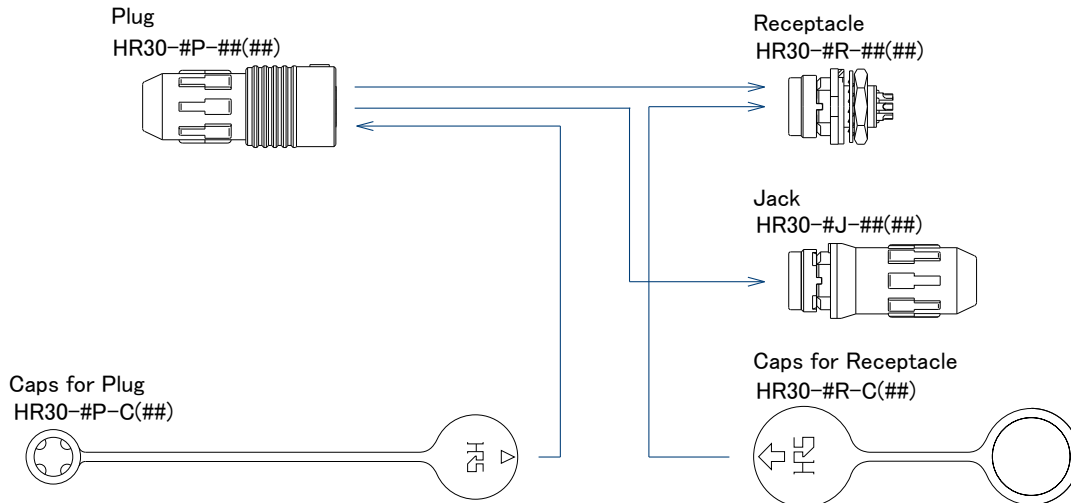

Note 1: Use connectors with matching shell sizes and No. of pos. Additionally, if the plug is a male contact product, use female contact products for the receptacle and jack.

Note 2: For crimp-type connectors, use compatible crimp terminals. (Please refer to the wiring procedure manual.)

Note 3: When using a cap for the receptacle, do not use the gasket attached to the receptacle.

Plug

● Solder Type

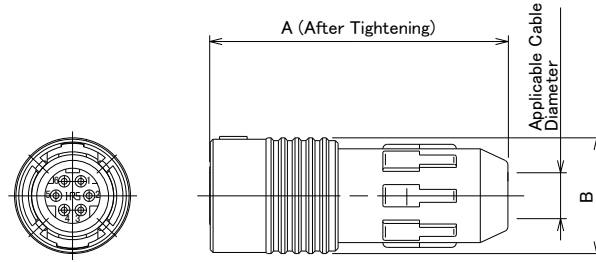

(Example of product appearance)

Unit : mm

Part No.	HRS No.	A	B	Applicable Cable Diameter	Solder Pot Inner Diameter	Purchase Unit
HR30-6P-3S(31)	CL0130-0004-1-31	29.8	φ 12.6	φ 4.2 to 5	φ 1.1	50pcs per tray
HR30-6P-6S(31)	CL0130-0010-4-31				φ 0.8	
HR30-6P-6P(31)	CL0130-0009-5-31	30.3				
HR30-6PA-3S(71)	CL0130-0021-0-71	29.8		φ 3.5 to 4.3	φ 1.1	
HR30-6PA-6S(71)	CL0130-0019-9-71				φ 0.8	
HR30-6PA-6P(71)	CL0130-0020-8-71	30.3				
HR30-7P-12S(71)	CL0130-0027-7-71	39.8	φ 15.5	φ 6.2 to 7	φ 0.6	
HR30-8P-12P(71)	CL0130-0026-4-71					

● Crimp Type

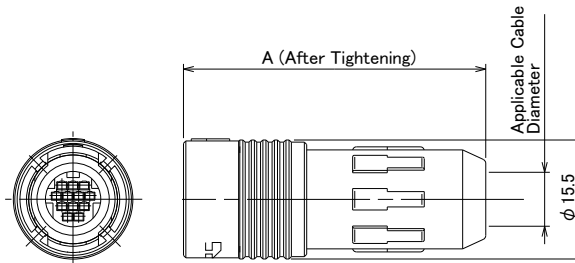

(Example of product appearance)

Unit : mm

Part No.	HRS No.	A	Applicable Cable Diameter	Applicable Crimp Contact	Purchase Unit
HR30-7P-10SC(71)	CL0130-0013-2-71	39.8	φ 6.2 to 7	HR30-SC-211	50pcs per tray
HR30-7P-12SC(71)	CL0130-0014-5-71				
HR30-8P-12PC(71)	CL0130-0015-8-71			HR30-PC-211	

Plug for Overmolds

● Solder Type

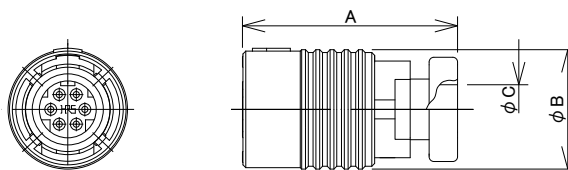

Unit : mm

Part No.	HRS No.	A	B	Applicable Cable Diameter	Solder Pot Inner Diameter	Purchase Unit
HR30-6PB-3S	CL0130-0034-2-00	22.7	φ 12.6	φ 5.2	φ 1.1	50pcs per tray
HR30-6PB-6S	CL0130-0032-7-00				φ 0.8	
HR30-6PD-6P	CL0130-0041-8-00	23.2				
HR30-7PB-12S	CL0130-0035-5-00	25.9	φ 15.5	φ 6.4	φ 0.6	
HR30-8PB-12P	CL0130-0030-1-00					

● Crimp Type

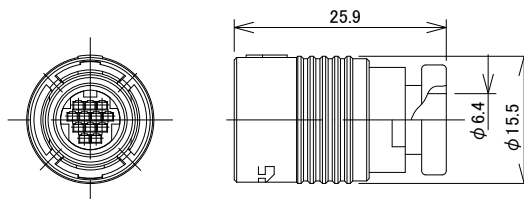

Unit : mm

Part No.	HRS No.	Applicable Crimp Contact	Purchase Unit
HR30-7PB-10SC	CL0130-0036-8-00	HR30-SC-211	50pcs per tray
HR30-7PB-12SC	CL0130-0033-0-00		
HR30-8PB-12PC	CL0130-0031-4-00	HR30-PC-211	

Receptacle

● Solder Type

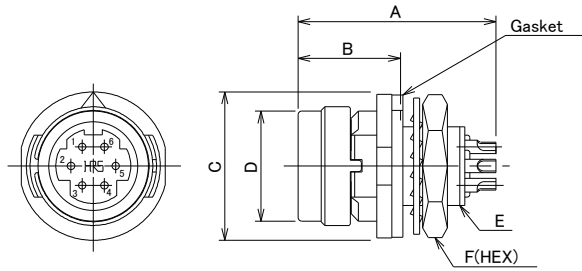

(Example of product appearance)

Unit : mm

Part No.	HRS No.	A	B	C	D	E	F	Solder Pot Inner Diameter	Purchase Unit
HR30-6R-3P(71)	CL0130-1003-4-71	16	8.3	$\phi 12$	$\phi 8.9$	M8 \times 0.75	10	$\phi 1.1$	50pcs per tray
HR30-6R-6P(71)	CL0130-1009-0-71							$\phi 0.8$	
HR30-6R-6S(71)	CL0130-1008-8-71	18.4							
HR30-7R-12P(31)	CL0130-1016-6-31	18.6	9.3	$\phi 15$	$\phi 11.5$	M11 \times 1	13	$\phi 0.6$	
HR30-8R-12S(31)	CL0130-1018-1-31								

● Crimp Type

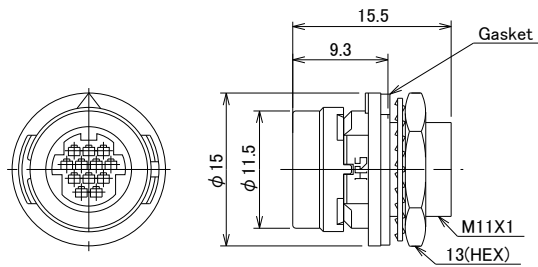

(Example of product appearance)

Shown with terminated and contacts installed.

Unit : mm

Part No.	HRS No.	Applicable Crimp Contact	Purchase Unit
HR30-7R-10PC(31)	CL0130-1012-5-31	HR30-PC-211	50pcs per tray
HR30-7R-12PC(31)	CL0130-1013-8-31		
HR30-8R-12SC(31)	CL0130-1014-0-31	HR30-SC-211	

● Through Hole Type

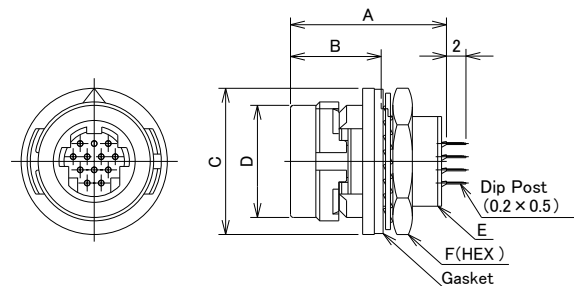

(Example of product appearance)

Unit : mm

Part No.	HRS No.	A	B	C	D	E	F	Purchase Unit
HR30-6R-6PD(71)	CL0130-1020-3-71	14.9	8.3	$\phi 12$	$\phi 8.9$	M8 \times 0.75	10	50pcs per tray
HR30-6R-6SD(71)	CL0130-1021-6-71	15.2						
HR30-7R-12PD(31)	CL0130-1017-9-31	16	9.3	$\phi 15$	$\phi 11.5$	M11 \times 1	13	
HR30-8R-12SD(31)	CL0130-1019-4-31							

Jack

● Solder Type

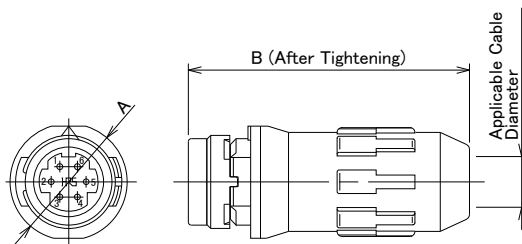

(Example of product appearance)

Unit : mm

Part No.	HRS No.	A	B	Applicable Cable Diameter	Solder Pot Inner Diameter	Purchase Unit
HR30-6J-6P(31)	CL0130-2009-6-31	φ 12	28.8	φ 4.2 to 5	φ 0.8	50pcs per tray
HR30-6JA-6P(71)	CL0130-2018-7-71			φ 3.5 to 4.3		
HR30-7J-12P(71)	CL0130-2020-9-71	φ 15	37.3	φ 6.2 to 7	φ 0.6	
HR30-8J-12S(71)	CL0130-2019-0-71					

● Crimp Type

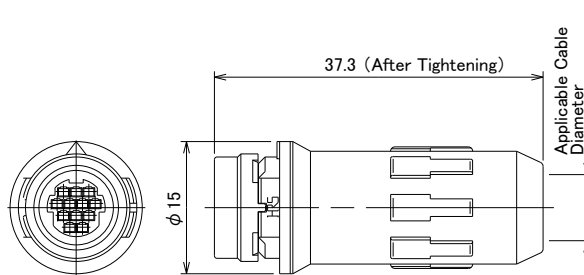

(Example of product appearance)

Unit : mm

Part No.	HRS No.	Applicable Cable Diameter	Applicable Crimp Contact	Purchase Unit
HR30-7J-10PC(71)	CL0130-2015-9-71	φ 6.2 to 7	HR30-PC-211	50pcs per tray
HR30-7J-12PC(71)	CL0130-2017-4-71			
HR30-8J-12SC(71)	CL0130-2016-1-71		HR30-SC-211	

Jack for Overmolds

● Solder Type

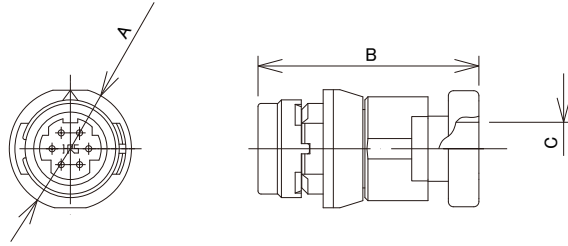

Unit : mm

Part No.	HRS No.	A	B	C	Solder Pot Inner Diameter	Purchase Unit
HR30-6JB-3P	CL0130-2029-0-00	ϕ 12.7	21.7	ϕ 5.2	ϕ 1.1	50pcs per tray
HR30-6JB-6P	CL0130-2021-1-00	ϕ 12			ϕ 0.8	
HR30-6JB-6S	CL0130-2028-0-00	ϕ 12.7	23.7	ϕ 6.4	ϕ 0.6	
HR30-7JB-12P	CL0130-2023-7-00	ϕ 15				
HR30-8JB-12S	CL0130-2024-0-00					

● Crimp Type

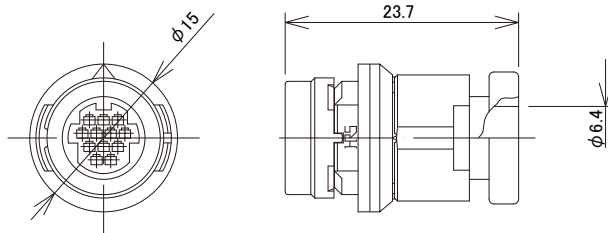

Unit : mm

Part No.	HRS No.	Applicable Crimp Contact	Purchase Unit
HR30-7JB-10PC	CL0130-2025-2-00	HR30-PC-211	50pcs per tray
HR30-7JB-12PC	CL0130-2022-4-00		
HR30-8JB-12SC	CL0130-2026-5-00	HR30-SC-211	

Cap

● for Plug

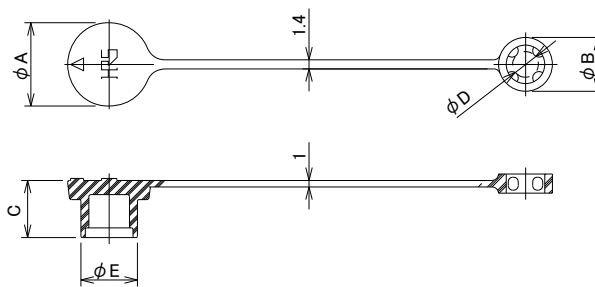

(Example of product appearance)

Unit : mm

Part No.	HRS No.	A	B	C	D	E	Applicable Cable Diameter	Purchase Unit
HR30-6P-C(31)	CL0130-3000-7-31	13	8.4	8.9	4	8.8	ϕ 4.2 to 5	20pcs per bag
HR30-7P-C(31)	CL0130-3004-8-31	16	10.4	10.5	6	11.4	ϕ 6.2 to 7	
HR30-8P-C(31)	CL0130-3003-5-31							

● for Receptacle

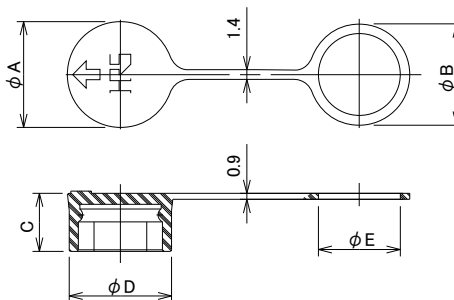

(Example of product appearance)

Unit : mm

Part No.	HRS No.	A	B	C	D	E	Remarks	Purchase Unit
HR30-6R-C(31)	CL0130-3001-0-31	12.6	11.8	7.5	12.1	9.1	-	20pcs per bag
HR30-7R-C(31)	CL0130-3002-2-31	15.5	14.8	8.5	15	12.1	Compatible with each size of HR30-7R and HR30-8R.	

● Cap Installation State Diagram

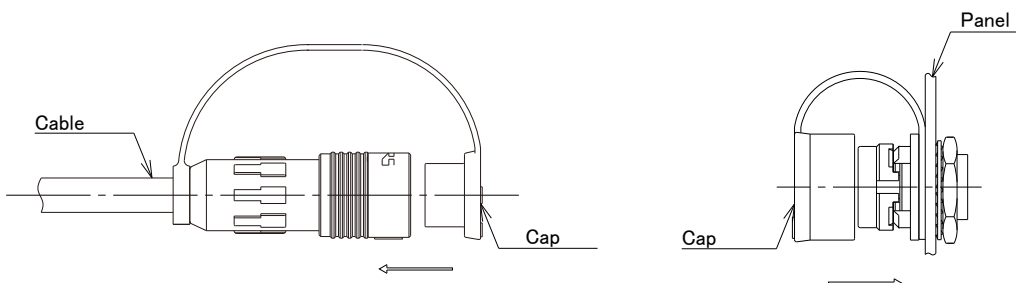

Crimp Contact

● Male Contact

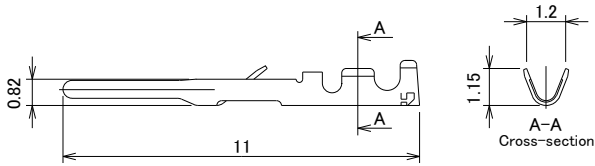

(Example of product appearance)

Type	Part No.	HRS No.	Purchase Unit
Loose Contact	HR30-PC-111	CL0130-0022-3-00	100pcs per bag
Reel Contact	HR30-PC-211	CL0130-0016-0-00	10,000pcs per reel

Note: Please use wires with a size of 26 to 30 AWG and an outer diameter of ϕ 1 Max.

● Female Contact

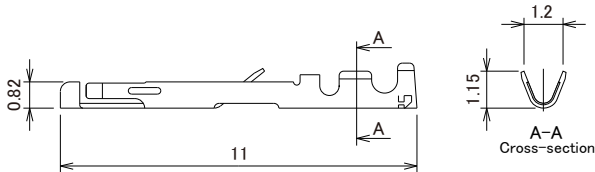

(Example of product appearance)

Type	Part No.	HRS No.	Purchase Unit
Loose Contact	HR30-SC-111	CL0130-0023-6-00	100pcs per bag
Reel Contact	HR30-SC-211	CL0130-0017-3-00	10,000pcs per reel

Note: Please use wires with a size of 26 to 30 AWG and an outer diameter of ϕ 1 Max.

Applicable Crimping Tools

For detailed information on the wiring method, please refer to the 'Cable Assembly Instruction' on our website.

● Termination Tools

Part No.	HRS No.	Applicable Connectors			
		Shell Size	Type	No. of Pos.	Contact Gender
HR30-6P-3S-T01	CL0150-0220-1-00	6	Plug	3	Female
HR30-6P-6S-T01	CL0150-0214-9-00			6	Female
HR30-6P-6P-T01	CL0150-0221-4-00			6	Male
HR30-7P-10SC-T01	CL0150-0228-3-00	7	Plug	10	Female
HR30-7P-12SC-T01	CL0150-0223-0-00			12	Female
HR30-8P-12PC-T01	CL0150-0227-0-00	8	Plug	12	Male
HR30-6R-3P-T01	CL0150-0225-5-00	6	Receptacle Jack	3	Male
HR30-6R-6P-T01	CL0150-0218-0-00			6	Male
HR30-6R-6S-T01	CL0150-0222-7-00			6	Female
HR30-7J-10PC-T01	CL0150-0231-8-00	7	Receptacle Jack	10	Male
HR30-7J-12PC-T01	CL0150-0230-5-00			12	Male
HR30-8J-12SC-T01	CL0150-0226-8-00	8	Receptacle Jack	12	Female

Note: The termination tools makes wiring work easier when used for soldering connections or for disassembling and assembling plugs and jacks.

● Cord Clamp Tightening Jig

Part No.	HRS No.	Applicable Connectors
HR30-6P-T02	CL0150-0216-4-00	for 3, 6pos.
HR30-8P-T02	CL0150-0224-2-00	for 10, 12pos.

Note: The Cord Clamp Tightening Jig is used to assemble the cord clamp through the cable and tighten the cord clamp to the specified torque.



Contact Crimping Tool

Type	Item	Part No.	HRS No.	Applicable Contact	Applicable Wire
Manual	Manual Crimping Tool	HT-102/HR30-1	CL0150-0229-6-00	HR30-SC-111	26 to 30 AWG
				HR30-PC-111	
Automatic	Automatic Crimp Press	CM-105C	CL0901-0001-0-00	-	-
	Applicator	AP105-HR30-1	CL0901-2049-0-00	HR30-SC-211 HR30-PC-211	26 to 30 AWG
Extraction Tool		HR30-TP	CL0150-0219-2-00	HR30-SC-111	-
				HR30-SC-211	
				HR30-PC-111	
				HR30-PC-211	

Receptacle Dip Post Arrangement Dimensions

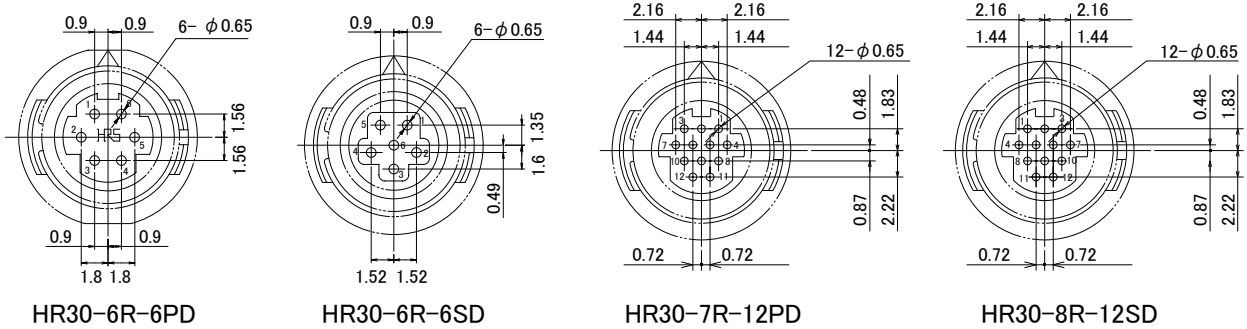

Note 1: The diagram shows the connector from the mating face side.

Note 2: The \triangle mark above indicates the position of the mating guide key.

Note 3: The recommended maximum thickness of the board is 1.2mm.

Note 4: The recommended tolerance for the board's arrangement dimensions is ± 0.03 mm. Additionally, the recommended tolerance for the through-hole diameter of the board is ± 0.02 mm.

Contact Arrangement and Panel Cut-out Dimensions

Contact Arrangement

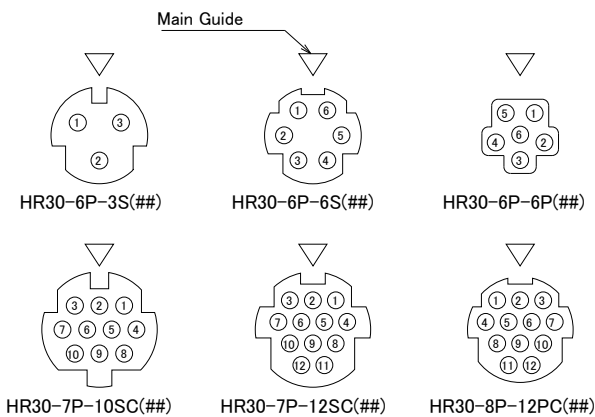

Mounting Hole Dimensions

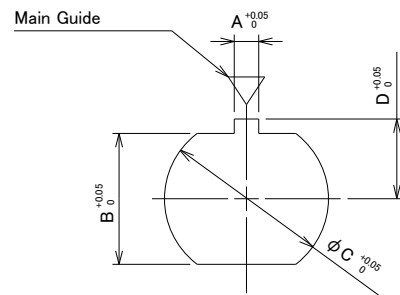

	A	B	C	D	Panel Thickness
3, 6pos.	1.25	6.45	8.05	3.95	0.7 to 2
10, 12pos.	1.35	9.25	11.05	5.45	0.7 to 3

Note 1: The contact arrangement shows the plug from the wiring side.

Note 2: To attach the connector to the panel, tighten it with a hex nut from the back side of the panel.

The recommended tightening torque for the hex nut is 0.5N·m for 3 and 6pos., and 0.8N·m for 10 and 12pos.

To prevent loosening, apply Henkel Japan Ltd.'s Loctite 263 and Loctite Primer 7649.

Precautions When Using Heat Shrink Tubing

For enhanced insulation and protection of the terminal soldering area, it is recommended to use heat shrink tubing on the soldered connection. However, please ensure that the heating range during the processing of the heat shrink tubing does not extend beyond the area shown in the diagram, particularly toward the resin section.

If the product is heated beyond the specified range and the resin is affected, the following issues may occur:

1. The C-ring may deform and fail to lock during mating.
2. The product may melt.

To prevent deformation of the C-ring in the receptacle and jack, it is recommended to mate the appropriate plug before heating. When heating, ensure the plug is fully inserted, pull the cord clamp section of the plug to confirm the lock is secure, and then proceed with heating. If heating is performed while partially mated, the C-ring may shrink and deform due to heat exposure, preventing proper locking.

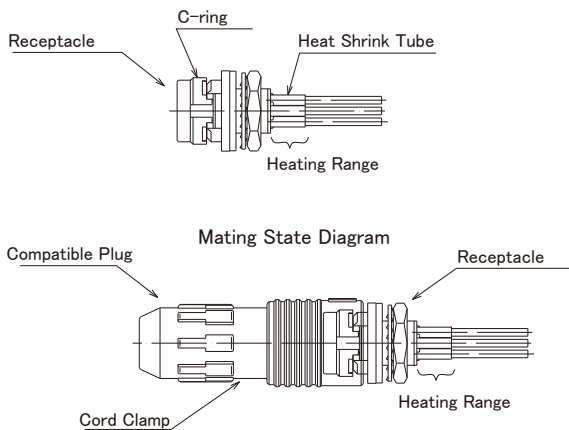

Precautions After Wiring (Common for Solder Type and Crimp Type)

After wiring this product, do not seal the wiring area with potting or similar materials. Potting may cause the O-ring to come off when the compatible plug is removed. If the product is used with the O-ring detached, it may no longer meet its waterproof performance specifications.

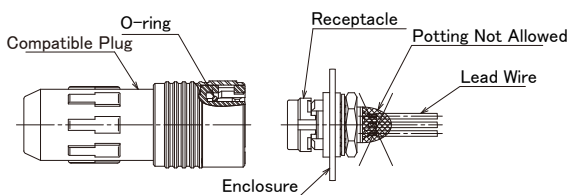

Handling Method of Connectors

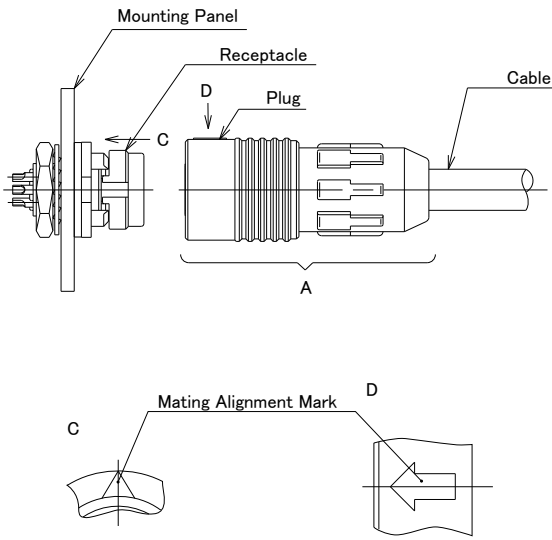
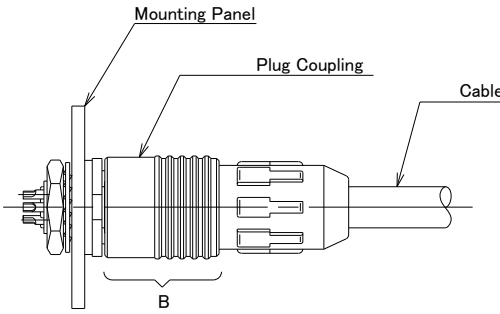
1. Insertion	2. Removal
	
<p>When mating, hold part A of the plug and align the mating alignment mark on the plug with the mating alignment mark on the receptacle, then push straight in for smooth mating.</p>	<p>When removing the plug from the mated state, hold the B part of the plug coupling and pull it straight out. This will allow for easy removal.</p>

Precautions

1. Turn off power to the circuit before connecting or disconnecting the connector.
2. Apply a minimum force of 30N to insert the connector. Then, lightly pull the cable to confirm the connector is securely mated and will not disconnect.
3. After mating, do not apply more than 30N of load in the direction indicated by the arrow. Excessive tensile force may damage the connector.

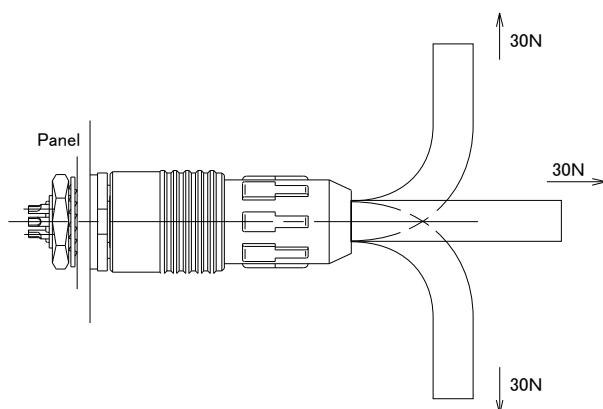

4. To maintain waterproof performance, clamping force, and cable rotation resistance, use cables within the specified diameter range. Performance may vary depending on cable structure, so please check in advance.
5. When assembling the connector and mounting it to equipment, use the specified tightening torque. Insufficient or excessive torque may cause loosening or damage.
6. For use in equipment subject to the Electrical Appliances and Materials Safety Act, please consult us separately.
7. Be aware that white alignment markings on the product may come off when exposed to solvents such as alcohol or when in contact with cable sheaths.

While Taking into Consideration

Specifications mentioned in this catalog are reference values.

When considering to order or use this product, please review the Drawing and Product Specifications sheets.

Use an appropriate cable when using the connector in combination with cables.

If considering usage of a non-specified cable, please contact your sales representative.

If assembly process is done by jigs & tools which are not identified by Hirose, the warranty of the product may be affected.

If considering usage for below mentioned applications, please contact your sales representative.

In cases where the application will demand a high level of reliability, such as automotive, medical instruments, public infrastructure, aerospace/defense etc. Hirose must review before assurance of reliability can be given.