

PRODUCT NUMBER
10063545-YYYHXLF

- LEAD FREE
- NONE= WITH TAPE(WITHOUT WATER PROOF BAG)
- B= WITHOUT TAPE(WITH WATER PROOF BAG)
- W= WITH TAPE(WITH WATER PROOF BAG)
- HIGH TEMPERATURE PLASTIC
SEE NOTE 1
- NO OF POSITIONS
SEE NOTE 3
- PIN PLATING
SEE SHEET 2
- BASE PART NO.

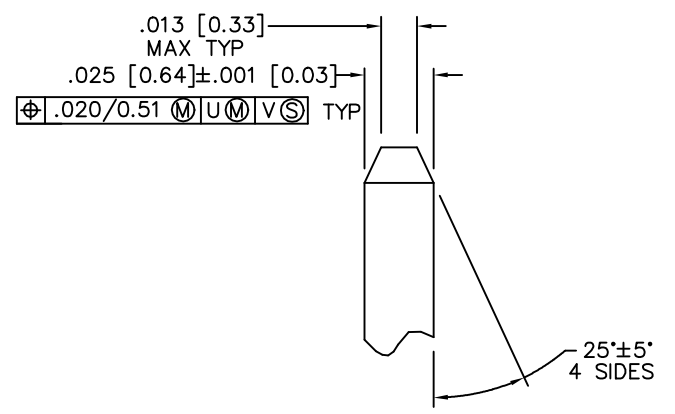

Mat'l. code NOTES 1 & 2		surface ISD 1302 ✓		tolerance ISD 406 ISD 1101		projection INCH/MM		product family BERGSTIK	
F	ELX-N-19761	J.H	12/17/14	tolerances unless otherwise specified		title BERGSTIK HEADER D/R .100/2.54cc STRAIGHT		sheet 1 of 2	
G	ELX-N-20014	J.H	01/19/15	angles	linear	scale 1:1		dwg no 10063545	
H	ELX-N-31185	MZ	10/23/18	0°±2°				size A3	
J	ELX-N-32690	MZ	2/15/19	dr	M.HERNANDEZ	11/04/05		type Product Customer Drawing	
K	ELX-N-46569	YQ	11/22/22	engr	S.FIERRRO	11/04/05			
L	ELX-N-52913	Mike	23/09/24	chr	S.FIERRRO	11/04/05			
				appd	S.FIERRRO	11/04/05			
sheet index	revision sheet	L	L						
		1	2						

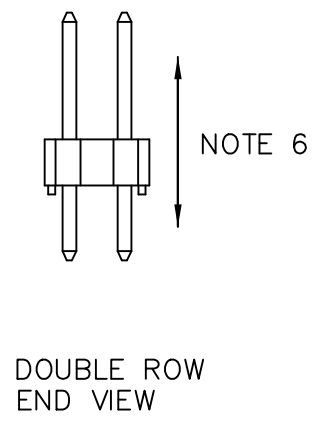
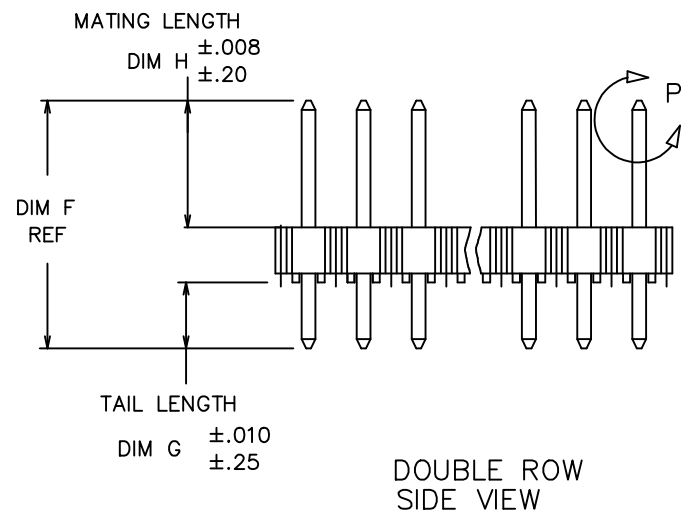