

P	LTR	DESCRIPTION	DATE	DWN	APVD
G		HOUSING RESIN CHANGED	27OCT2021	SCB	KJK
H		RIB FEATURE IS ADDED IN THE STANDOFF FEATURE	19FEB2026	RS	GVP

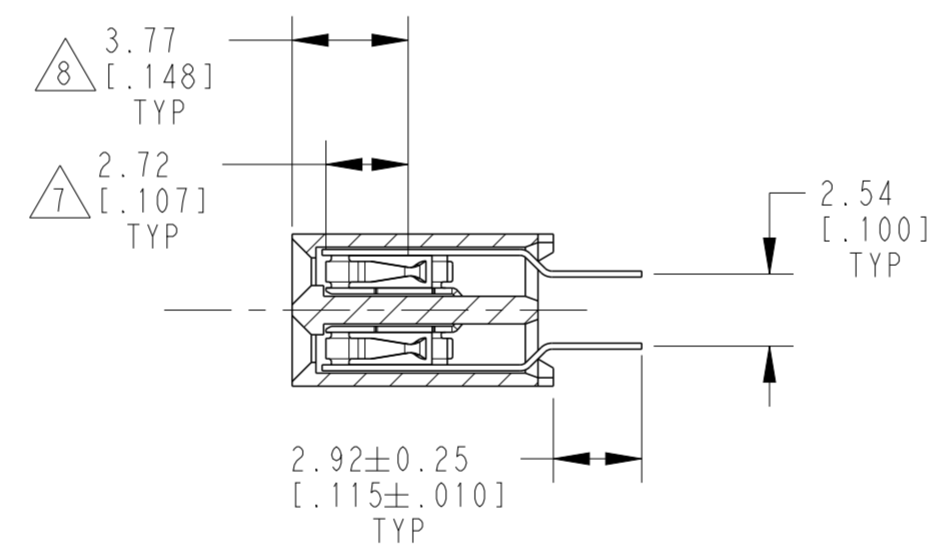
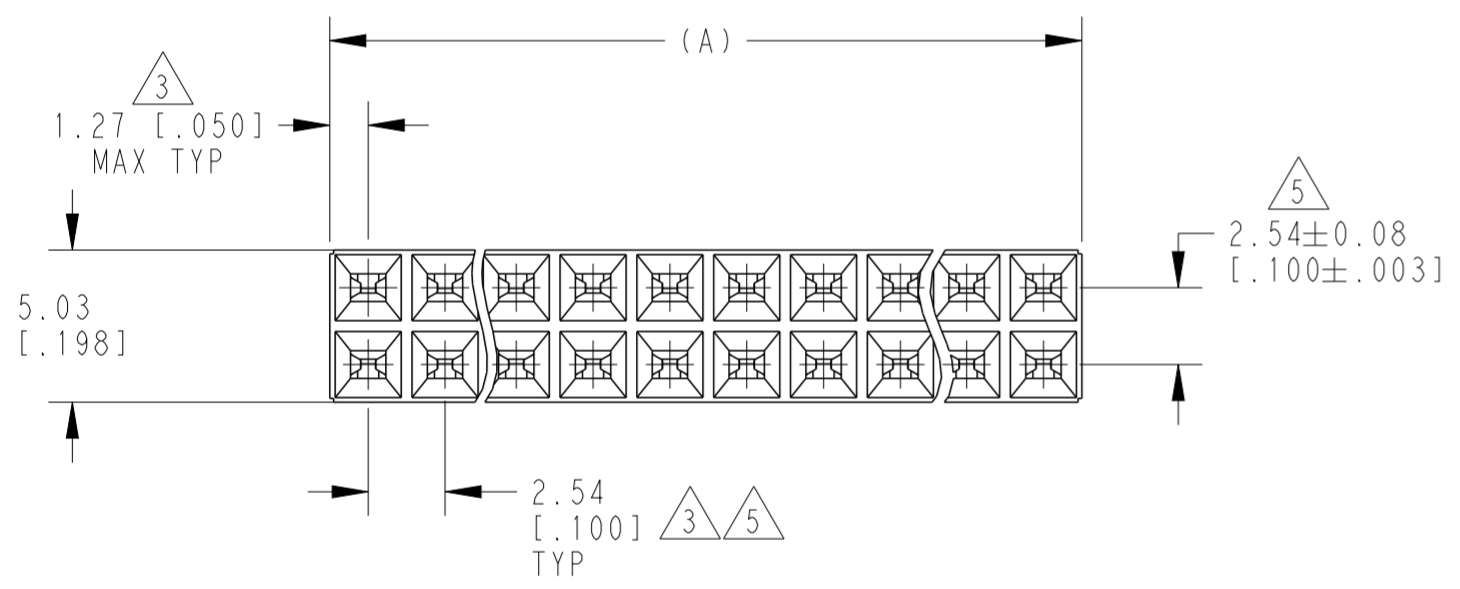
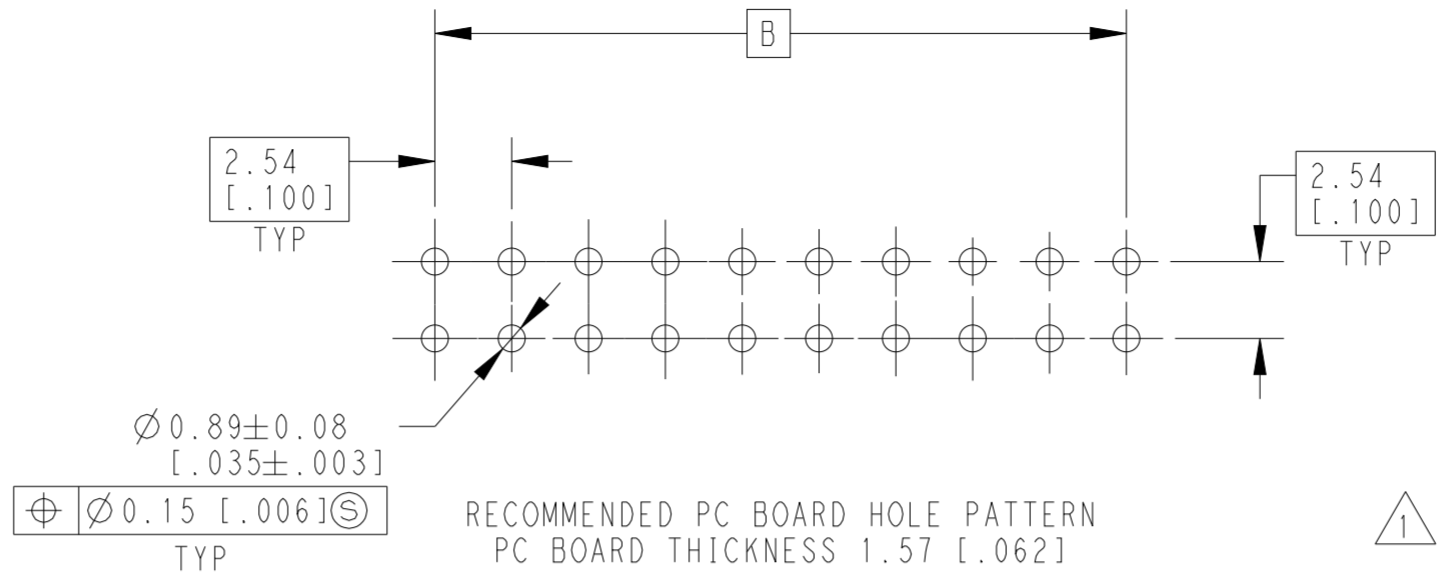
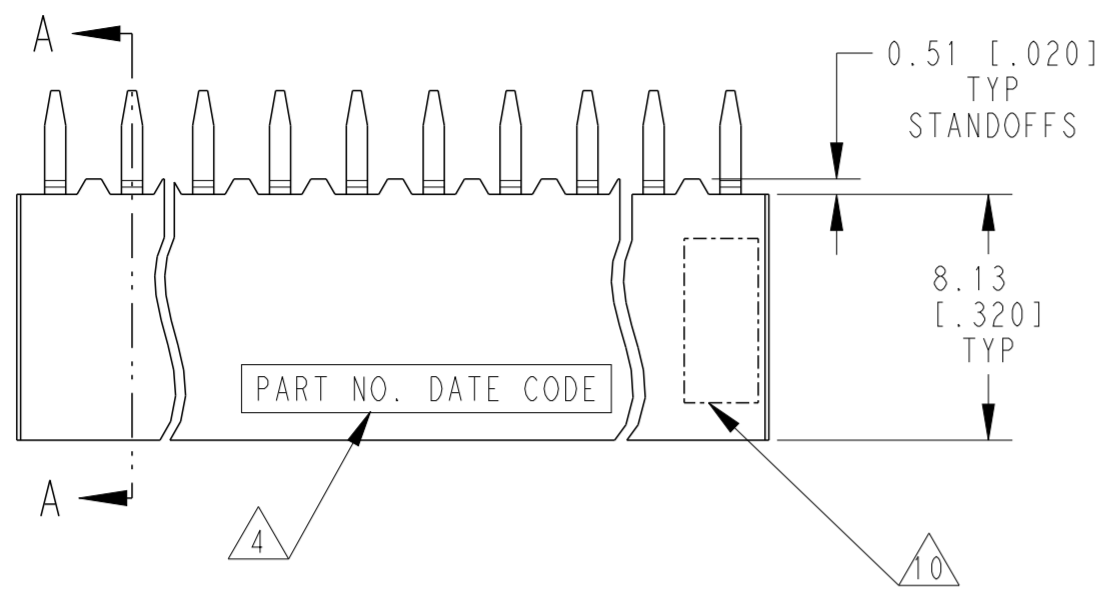

SECTION A-A

- 1 HOUSING: FLAME RETARDANT, GLASS FILLED, POLYESTER, COLOR: BLACK. CONTACT: PHOSPHOR BRONZE
- 2 CONTACT: DUPLEX PLATED 0.00025[.000010] MIN GOLD IN CONTACT AREA, 0.00381-0.00762[.000150 -.000300] BRIGHT TIN-LEAD ON LEADS ALL OVER 0.00127[.000050] MINIMUM NICKEL.
- 3 THESE DIMENSIONS PERTAIN TO CAVITY CENTERLINES ONLY - NOT TO CONTACT LOCATIONS
- 4 PART NUMBER AND DATE CODE ARE MARKED IN APPROXIMATE LOCATION SHOWN, EITHER SIDE.
- 5 TOLERANCE IS NON-CUMULATIVE.
- 6 2 POSITION DATE CODE IS MARKED OPPOSITE SIDE OF TE LOGO.
- 7 POINT-OF-MEASUREMENT DIMENSION FOR PLATING THICKNESS (INSIDE CONTACT BEAM).
- 8 POINT-OF-CONTACT DIMENSION.
- 9 NO PART NUMBER MARKING REQUIRED FOR THIS PART.
- 10 TE LOGO AND CSA LOGO ARE MOLDED INTO HOUSING.
- 11 CONTACT: DUPLEX PLATED 0.00025[.000010] MIN GOLD IN CONTACT AREA, 0.00381-0.00762[.000150 -.000300] MATTE TIN ON LEADS ALL OVER 0.00127[.000050] MINIMUM NICKEL
- 12 ROHS 2002/95/EC COMPLIANT

THIS DRAWING IS A CONTROLLED DOCUMENT.		DWN M. BINNER 06NOV2002	TE Connectivity	
DIMENSIONS: mm [INCHES]		CHK J. OLSON 06NOV02		
TOLERANCES UNLESS OTHERWISE SPECIFIED:		APVD J. OLSON 06NOV02	NAME RECEPTACLE ASSEMBLY, MOD IV, DOUBLE ROW, TOP ENTRY, .100X.100CL, VERTICAL MOUNT, AMPMODU	
0 PLC ±	1 PLC ±	PRODUCT SPEC 108-25022	SIZE A2	CAGE CODE 00779
2 PLC ±0.13[.005]	3 PLC ±	APPLICATION SPEC 114-25018	DRAWING NO C-147424	RESTRICTED TO -
4 PLC ±	ANGLES ±	WEIGHT -	SCALE 4:1 SHEET 1 OF 2 REV H	
FINISH		CUSTOMER DRAWING		

REVISIONS				
P	LTR	DESCRIPTION	DATE	APVD
-		SEE SHEET 1	-	-

FINISH	B	A	NO OF POSN	PART NUMBER
2	99.06[3.900]	101.60[4.000]	80	4-147424-0
2	96.52[3.800]	99.06[3.900]	78	3-147424-9
2	93.98[3.700]	96.52[3.800]	76	3-147424-8
2	91.44[3.600]	93.98[3.700]	74	3-147424-7
2	88.90[3.500]	91.44[3.600]	72	3-147424-6
2	86.36[3.400]	88.90[3.500]	70	3-147424-5
2	83.82[3.300]	86.36[3.400]	68	3-147424-4
2	81.28[3.200]	83.82[3.300]	66	3-147424-3
2	78.74[3.100]	81.28[3.200]	64	3-147424-2
2	76.20[3.000]	78.74[3.100]	62	3-147424-1
2	73.66[2.900]	76.20[3.000]	60	3-147424-0
2	71.12[2.800]	73.66[2.900]	58	2-147424-9
2	68.58[2.700]	71.12[2.800]	56	2-147424-8
2	66.04[2.600]	68.58[2.700]	54	2-147424-7
2	63.50[2.500]	66.04[2.600]	52	2-147424-6
2	60.96[2.400]	63.50[2.500]	50	2-147424-5
2	58.42[2.300]	60.96[2.400]	48	2-147424-4
2	55.88[2.200]	58.42[2.300]	46	2-147424-3
2	53.34[2.100]	55.88[2.200]	44	2-147424-2
2	50.80[2.000]	53.34[2.100]	42	2-147424-1
2	48.26[1.900]	50.80[2.000]	40	2-147424-0
2	45.72[1.800]	48.26[1.900]	38	1-147424-9
2	43.18[1.700]	45.72[1.800]	36	1-147424-8
2	40.64[1.600]	43.18[1.700]	34	1-147424-7
2	38.10[1.500]	40.64[1.600]	32	1-147424-6
2	35.56[1.400]	38.10[1.500]	30	1-147424-5
2	33.02[1.300]	35.56[1.400]	28	1-147424-4
2	30.48[1.200]	33.02[1.300]	26	1-147424-3
2	27.94[1.100]	30.48[1.200]	24	1-147424-2
2	25.40[1.000]	27.94[1.100]	22	1-147424-1
2	22.86[.900]	25.40[1.000]	20	1-147424-0
2	20.32[.800]	22.86[.900]	18	147424-9
2	17.78[.700]	20.32[.800]	16	147424-8
2	15.24[.600]	17.78[.700]	14	147424-7
2	12.70[.500]	15.24[.600]	12	147424-6
2	10.16[.400]	12.70[.500]	10	147424-5
2	7.62[.300]	10.16[.400]	8	147424-4
2	5.08[.200]	7.62[.300]	6	147424-3
2	2.54[.100]	5.08[.200]	4	147424-2
2	2.54[.100]	2.54[.100]	2	147424-1

SUPERSEDED BY 7-147424-4

SUPERSEDED BY 7-147424-0

SUPERSEDED BY 6-147424-6

SUPERSEDED BY 6-147424-5

SUPERSEDED BY 6-147424-0

9 OBSOLETE

FINISH	B	A	NO OF POSN	PART NUMBER
11	99.06[3.900]	101.60[4.000]	80	9-147424-0
11	96.52[3.800]	99.06[3.900]	78	8-147424-9
11	93.98[3.700]	96.52[3.800]	76	8-147424-8
11	91.44[3.600]	93.98[3.700]	74	8-147424-7
11	88.90[3.500]	91.44[3.600]	72	8-147424-6
11	86.36[3.400]	88.90[3.500]	70	8-147424-5
11	83.82[3.300]	86.36[3.400]	68	8-147424-4
11	81.28[3.200]	83.82[3.300]	66	8-147424-3
11	78.74[3.100]	81.28[3.200]	64	8-147424-2
11	76.20[3.000]	78.74[3.100]	62	8-147424-1
11	73.66[2.900]	76.20[3.000]	60	8-147424-0
11	71.12[2.800]	73.66[2.900]	58	7-147424-9
11	68.58[2.700]	71.12[2.800]	56	7-147424-8
11	66.04[2.600]	68.58[2.700]	54	7-147424-7
11	63.50[2.500]	66.04[2.600]	52	7-147424-6
11	60.96[2.400]	63.50[2.500]	50	7-147424-5
11	58.42[2.300]	60.96[2.400]	48	7-147424-4
11	55.88[2.200]	58.42[2.300]	46	7-147424-3
11	53.34[2.100]	55.88[2.200]	44	7-147424-2
11	50.80[2.000]	53.34[2.100]	42	7-147424-1
11	48.26[1.900]	50.80[2.000]	40	7-147424-0
11	45.72[1.800]	48.26[1.900]	38	6-147424-9
11	43.18[1.700]	45.72[1.800]	36	6-147424-8
11	40.64[1.600]	43.18[1.700]	34	6-147424-7
11	38.10[1.500]	40.64[1.600]	32	6-147424-6
11	35.56[1.400]	38.10[1.500]	30	6-147424-5
11	33.02[1.300]	35.56[1.400]	28	6-147424-4
11	30.48[1.200]	33.02[1.300]	26	6-147424-3
11	27.94[1.100]	30.48[1.200]	24	6-147424-2
11	25.40[1.000]	27.94[1.100]	22	6-147424-1
11	22.86[.900]	25.40[1.000]	20	6-147424-0
11	20.32[.800]	22.86[.900]	18	5-147424-9
11	17.78[.700]	20.32[.800]	16	5-147424-8
11	15.24[.600]	17.78[.700]	14	5-147424-7
11	12.70[.500]	15.24[.600]	12	5-147424-6
11	10.16[.400]	12.70[.500]	10	5-147424-5
11	7.62[.300]	10.16[.400]	8	5-147424-4
11	5.08[.200]	7.62[.300]	6	5-147424-3
11	2.54[.100]	5.08[.200]	4	5-147424-2
11	2.54[.100]	2.54[.100]	2	5-147424-1

6 9 OBSOLETE

THIS DRAWING IS A CONTROLLED DOCUMENT.		DWN M. BINNER 06NOV2002	 TE Connectivity	
DIMENSIONS: mm [INCHES]		CHK J. OLSON 06NOV02		
TOLERANCES UNLESS OTHERWISE SPECIFIED: 0 PLC ± 1 PLC ± 2 PLC ±0.13[.005] 3 PLC ± 4 PLC ± ANGLES ± FINISH		APVD J. OLSON 06NOV02	NAME RECEPTACLE ASSEMBLY, MOD IV, DOUBLE ROW, DUAL ENTRY, .100X.100CL, VERTICAL MOUNT, AMPMODU	
MATERIAL 1		PRODUCT SPEC 108-25022	SIZE A2	CAGE CODE 00779
		APPLICATION SPEC 114-25018	DRAWING NO 147424	RESTRICTED TO -
		WEIGHT -	SCALE 5:1	SHEET 2 OF 2
		CUSTOMER DRAWING	REV H	